

Verso le nuove frontiere tecnologiche del mercato globale  
Moving towards new technological frontiers of the global market  
Brechen Sie mit uns auf zu den neuen technologischen Horizonten des globalen Marktes  
Vers les nouvelles frontières technologiques du marché global  
Hacia las nuevas fronteras tecnológicas del mercado global

ManciniUtensili  
Diamond Tools Industry

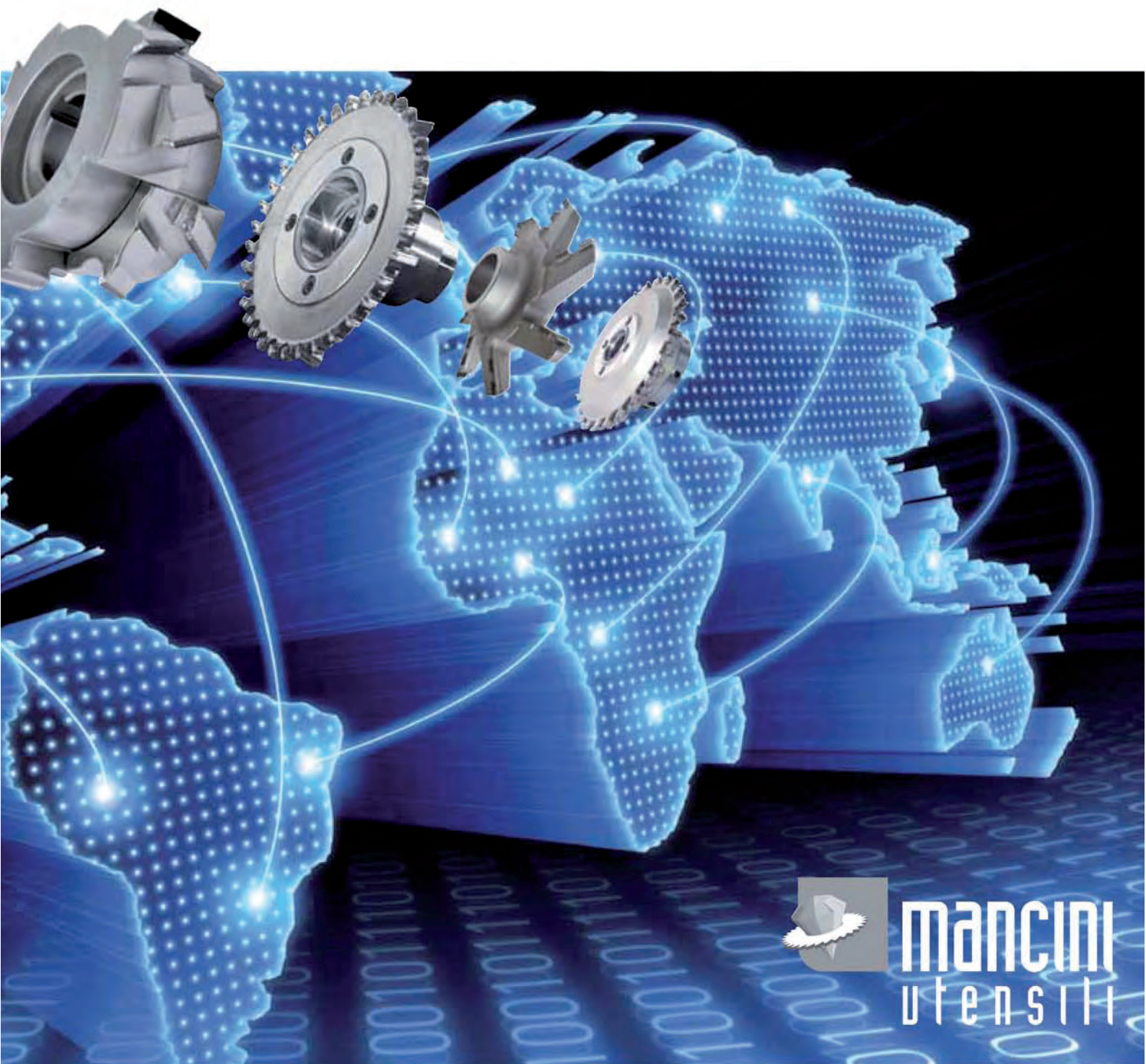

**MANCINI**  
utensili

## LISTINO PREZZI 2016

PRICE LIST • PREISLISTE • LISTE DE PRIX • LISTA DE PRECIOS



# Legenda

## Abbreviations

## Abkürzungen

## Abréviations

## Abreviaturas

### D

Diametro  
Diameter  
Durchmesser  
Diamètre  
Diámetro

### d

Foro  
Bore  
Bohrung  
Alésage  
Agujero

### H

Altezza diamante  
Dia-tip height  
PKD-Bestückungshöhe  
Hauteur diamant  
Altura diamante

### LT

Lunghezza totale  
Overall length  
Gesamtlänge  
Longueur totale  
Longitud total

### NL

Altezza di taglio  
Cutting length  
Nutzlänge  
Longueur utile  
Altura de corte

### PL

Numero placchette  
Number of tips  
Schneidenzahl  
Nombre de plaquettes  
Número de placas

### R

Raggio  
Radius  
Radius  
Rayon  
Radio

### S

Attacco  
Shank  
Schaft  
Queue  
Mango

### Z

Numero denti  
Number of teeth  
Zähnezahl  
Nombre de dents  
Número de dientes

### DP

Diamante policristallino  
Polycrystalline diamond  
Polykristalliner Diamant  
Diamant polycristallin  
Diamante policristalino

### HW

Metallo duro  
Hard metal  
Hartmetall  
Métal dur  
Metal duro

### b

Spessore corpo lama  
Steel plate thicknesser  
Sägeblattstärke  
Épaisseur du corps de la lame  
Espesor cuerpo

### V<sub>c</sub>

Velocità di taglio [ $m s^{-1}$ ] =  $\pi \cdot D \cdot n / (1000 \cdot 60)$   
Cutting speed  
Schnittgeschwindigkeit  
Vitesse de coupe  
Velocidad de corte

### V<sub>a</sub>

Velocità di avanzamento [ $m min^{-1}$ ] =  $f_z \cdot n \cdot z / 1000$   
Cutting speed  
Vorschubgeschwindigkeit  
Vitesse d'avance  
Velocidad de corte

### vi/t

Velocità avanzamento incisore/truciolatore  
Feeding speed scorer/hogger  
Vorschubgeschwindigkeit Ritzsäge/Zerspaner  
Vitesse d'avance inciseur/déchiporteur  
Velocidad de avance incisor/triturador

### vt/t

Velocità avanzamento truciolatore/truciolatore  
Feeding speed hogger/hogger  
Vorschubgeschwindigkeit Zerspaner/Zerspaner  
Vitesse d'avance déchiporteur/déchiporteur  
Velocidad de avance triturador/triturador



# Legenda Abbreviations Abkürzungen Abréviations Abreviaturas



Regime giri  $n \text{ min}^{-1} = V_c / (\pi \cdot D) \cdot (1000 \cdot 60)$   
Revolutions rating  
Drehgeschwindigkeit  
Taux de rotation  
Régimen de las revoluciones

**$f_z$**   
Avanzamento per dente [mm] =  $V_a / (n \cdot z) \cdot 1000$   
Feeding per teeth  
Vorschub pro Zahn  
Avance par dent  
Avance de diente

**$f$**   
Avanzamento per giro [mm] =  $f_z \cdot z$   
Feeding per revolution  
Vorschub pro Umdrehung  
Avance par tour  
Avance por revolución

**$f_{zeff}$**   
Avanzamento effettivo del dente [mm]  
Effective feeding of teeth  
Effektiver Vorschub pro Zahn  
Avance effective de la dent  
Avance de diente efectivo

**$t$**   
Profondità tagliente [mm] =  $f_z^2 / (4 \cdot D)$   
Cutting edge depth  
Zahntiefe  
Profondeur de tranchant  
Profundidad de paso de cuchilla

**$a_e$**   
Profondità di taglio  
Cut depth  
Schnitttiefe  
Profondeur de coupe  
Profundidad de corte

**$h_m$**   
Spessore medio del truciolo [mm] =  $f_z \sqrt{a_c / D}$   
Average thickness of chip  
Span-Durchschnittsmass  
Epaisseur moyenne des copeaux  
Espesor medio de la virula

**$N$**   
Potenza assorbita N/kw =  $B \cdot A \cdot V_a \cdot K / 9000 \times 1,36$   
Power consumption  
Stromverbrauch  
Consommation d'énergie  
Consumo de energia



Pinze  
Collets  
Spanndorn  
Pinces  
Pinzas



Ghiere  
Locking rings  
Ringmutter  
Collier de serrage  
Virolas de bloqueo

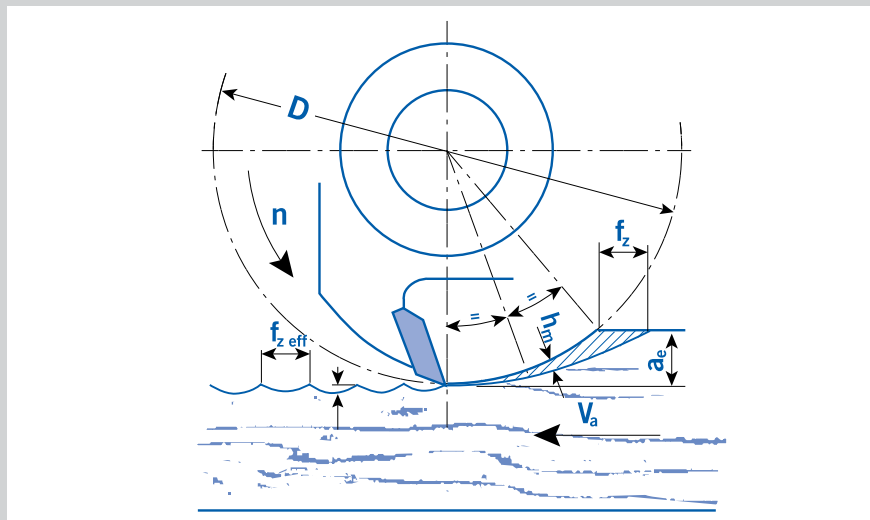

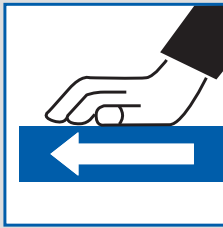

Impiego degli utensili  
Tool usage  
Werkzeug-Verwendung  
Emploi des outils  
Uso de las herramientas

**MAN****TIPO DI AVANZAMENTO**

Gli utensili marcati MAN possono essere usati con avanzamento manuale del pezzo in direzione contraria alla rotazione dell'utensile.

Gli utensili marcati MEC devono essere usati per lavorazioni con avanzamento meccanico.

**FEED**

Tools marked with MAN may be used with manual feed. The workpiece follows the opposite direction of the tool rotation.

Tools marked with MEC must be used with mechanical feed.

**VORSCHUB**

Die Werkzeuge mit dem Zeichen MAN können mit dem Handvorschub im Gegenlauf benützt werden.

Die Werkzeuge mit dem Zeichen MEC müssen mit mechanischem Vorschub benützt werden.

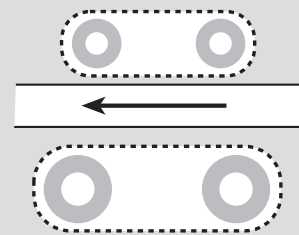
**MEC****TYPE D'AVANCE**

Les outils marqués MAN peuvent être employés avec avance manuelle de la pièce en direction opposée à la rotation de l'outil.

Les outils marqués MEC doivent être employés avec avance mécanique.

**TIPO DE AVANCE**

Las herramientas marcadas con MAN pueden ser usadas con avance manual de la pieza en dirección contraria a la rotación de la herramienta.

Las herramientas marcadas con MEC deben ser usadas para trabajos con avance mecánico.

**m / 1'****VELOCITA' DI AVANZAMENTO / FEED RATE / VORSCHUBGESCHWINDIGKEIT / VITESSE D'AVANCE / VELOCIDAD DE AVANCE**



Impiego degli utensili  
Tool usage  
Werkzeug-Verwendung  
Emploi des outils  
Uso de las herramientas

MANCINI UTENSILI

LH

RH

RH

LH

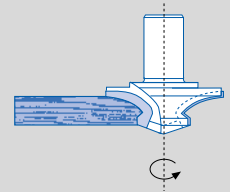
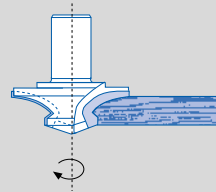
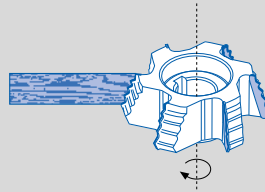
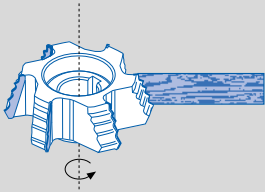

**SENSO DI ROTAZIONE**

In mancanza di specifica la rotazione dell'utensile è da intendersi "RH".

**DIRECTION OF ROTATION**

If not specified, the tool will be made with "RH" rotation.

**DREHRICHTUNG**

Ohne Spezifikation ist die Drehrichtung des Werkzeuges "RH".

**SENS DE ROTATION**

Si le sens de rotation n'est pas spécifié, l'outil est considéré avec rotation "RH".

**SENTIDO DE ROTACION**

Sin especificación, la dirección de la rotación de la herramienta se considera "RH".

MAN

n (min - max)

MEC

n max

**VELOCITA' DI ROTAZIONE**

Rispettare le indicazioni riportate sull'utensile.

**ROTATION SPEED**

Please follow the instructions engraved on the tool.

**DREHGESCHWINDIGKEIT**

Man soll die Anweisung auf den Werkzeugen beachten.

**VITESSE DE ROTATION**

Respecter les indications marquées sur l'outil.

**VELOCIDAD DE ROTACION**

Respectar las indicaciones marcadas sobre la herramienta.



**Informazioni tecniche**  
**Technical information**  
**Technische Informationen**  
**Informations techniques**  
**Informaciones técnicas**

MANCINI UTENSILI

**Valori indicativi per le velocità di taglio e avanzamento per dente nelle lame**  
**Indicative values for the cutting speeds and feeding for teeth in the saw blade**  
**Näherungswert der Schneide Geschwindigkeit und Zahnvorschub für Sägeblätter**  
**Valeurs indicatives pour les vitesses de coupe et avance par dent des lames**  
**Valores indicativos por las velocidades de corte e valores avance de diente para sierra circulares**

Materiali Materials Werkstoff Materiaux Materiales	Vc m/s	Fz
Truciolari grezzi Chipboard raw Rohspanplatte Panneaux de particules bruts Aglomerado crudo	60/80	0,3
Truciolari con rivestimento plastico Chipboard, plastic coated Spanplatte mit Kunststoffbeschichtung Panneaux de particules avec rev. plastique Aglomerado con revestimiento de plastico	60/80	0,03-0,06
Stratificati (HPL/CPL) Laminated panels Verbundplatten Panneaux stratifiés Panels laminados	50/70	0,01-0,08
Bordo soft Soft board Soft board Plance soupe Tabla blanda	60/100	0,15
Truciolari con laminato Particle board with laminate Spanplatte mit laminat Panneaux de particules stratifiés Fibra de madera con laminado	50/80	0,03-0,06
Pannelli MDF/HDF Medium/High density fiber board MDF/HDF Rohplatten Panneaux MDF/HDF Panels de MDF/HDF	60/80	0,1-0,3
Legno compensato Plywood Sperrholz Contré-plaqué Madera contrachapada	40/65	0,02-0,06
Termoindurenti (Pertinax/Resintex/etc.) Duroplast Duroplastischen Termodurcissable Termoestable	50/80	0,02-0,05

Materiali Materials Werkstoff Materiaux Materiales	Vc m/s	Fz
Termoplastici (PA/PF/PP) Thermoplastic Thermoplastische Thermoplastique Termoplástico	60/90	0,05-0,08
Rinforzati (GFK/CFK) Fiber reinforced plastics Verstärkten kunst stoffplatten Panneaux en plastique renforcé Panel de plastico reforzado	40/60	0,01-0,03
Polimeri tecnici (Corian/Varicor) Polymer bound boards Technische polymere Polymères techniques Polimeros técnicos	60/90	0,05-0,15
Cartongesso Sandwich-type plaster boards Gipskarton Plaque de plâtre Cartón de yeso	40/65	0,05-0,20
Fibrocemento Fibre cement boards Platten Panneaux fibrocemento Panels fibrocemento	20/40	0,01-0,03
Pannelli di lana di roccia Rockwool Platten aus steinwolle Panneaux de laine de roche Panels de lana de roca	30/50	0,07-0,15
Circuiti stampati Printed circuit boards Leiterplatten Circuits imprimés Placas de circuito impreso	45/65	0,01-0,03



Informazioni tecniche  
Technical information  
Technische Informationen  
Informations techniques  
Informaciones técnicas

MANCINI UTENSILI

**Valori indicativi per le velocità di taglio nelle frese**

**Indicative values for the cutting speeds in the cutterheads**

**Näherungswert der Schneide Geschwindigkeit in den Fräser**

**Valeurs indicatives pour les vitesses de coupe dans les fraises**

**Valores indicativos por las velocidades de corte en los fresas**

Materiali Materials Werkstoff Materiaux Materiales	Vc (m s <sup>-1</sup> )
Legni teneri Soft woods Weichholz Bois tendres Maderas blandas	65-100
Legni duri Soft woods Weichholz Bois tendres Maderas blandas	55-90
Truciolari Soft woods Weichholz Bois tendres Maderas blandas	70-95

Materiali Materials Werkstoff Materiaux Materiales	Vc (m s <sup>-1</sup> )
Truciolari con rivestimento plastico Soft woods Weichholz Bois tendres Maderas blandas	50-75
Pannelli laminati Soft woods Weichholz Bois tendres Maderas blandas	40-70



Informazioni tecniche  
 Technical information  
 Technische Informationen  
 Informations techniques  
 Informaciones técnicas

MANCINI UTENSILI

**Avanzamento per dente in fresatura (Fz)**

**Feed rate for tooth millin (Fz)**

**Vorschub pro zahn Fräser (Fz)**

**Avance de diente fraisage (Fz)**

**Avance par dent molienda (Fz)**

Materiali Materials Werkstoff Materiaux Materiales	Fz mm
Legno laminato Laminated woods Sperrholz Bois stratifié Madera laminada	0,40 - 0,50
Pannello grezzo Raw panels Roh-panel Panneau brut Panel de prima	0,50 - 0,70

Materiali Materials Werkstoff Materiaux Materiales	Fz mm
Pannello laminato Laminated panels Verbundplatte Panneau stratifié Panel laminados	0,20 - 0,40
Impiallacciato Veneered panels Furniert Plaqués Chapeada	0,10 - 0,15

**Qualità di taglio indicata per avanzamento effettivo del dente "Fz eff"**

**Quality recommended effective feed rate per tooth "Fz eff"**

**Qualität der schnitt für tatsächlichen fortschritt der zahn "Fz eff"**

**Qualité recommandé de coupe pour les progrès réels de la dent "Fz eff"**

**Calidad recomienda cortar para el progreso real del diente "Fz eff"**

Fine Finish Finish Finish Fino	0,3 - 0,8 mm
Media Medium Durchschnitt Moyenne Promedio	0,8 - 2,5 mm
Grossa Coarse Brutto Brut Bruto	2,5 - 5 mm

Valori consigliati Recommended values Empfohlenen werte Valeurs recommandées Valores recomendados	0,3 - 1,5 mm
---	--------------





# Indice

## Table of contents

## Inhaltsverzeichnis

## Index

## Indice

**Pag. 11**

Lame circolari  
Circular saw blades  
Sägeblätter  
Lames circulaires  
Sierras circulares

**Pag. 12**

Incisori  
Scoring saw blades  
Ritzsägeblätter  
Inciseurs  
Incisores

**Pag. 14**

Lame per fibramento  
Saw blades fibre cement boards  
Kreissägeblätter für Hartfaserplatten  
Lames pour fibre cimentées  
Sierra para fibra cementados

**Pag. 16**

Truciolatori  
Hoggers  
Zerspaner  
Déchiqueteurs  
Trituradores

**Pag. 26**

Frese a rettificare per bordatrici  
Jointing cutterheads for edge banding machines  
Fügefräser für Kantenbearbeitungsmaschinen  
Fraises à rectifier pour plaqueuses de chants  
Fresas para rectificar con encoladoras de cantos

**Pag. 33**

Frese antischeggia per squadatrici doppie  
Anti-chipping cutterheads for double end tenoners  
Schutzfräser für Doppelendprofiler  
Fraises à rectifier pour façonneuses doubles  
Fresas anti-astilla para escuadradoras dobles

**Pag. 39**

Frese a rifilare  
Edge jointing cutterheads  
Bündigfräser  
Fraises pour affleurage  
Fresas para cantear

**Pag. 43**

Lame / frese per scanalature  
Grooving saw blades / grooving cutters  
Nutsägeblätter / Nutfräser  
Lames / fraises à rainier  
Sierras / fresas para ranurar

**Pag. 51**

Frese per postforming/preforming  
Postforming/preforming cutterheads  
Postforming-und Preformingfräser  
Fraises pour postforming/preforming  
Fresas para postforming/preforming

**Pag. 58**

Frese per softforming  
Softforming cutterheads  
Softformingfräser  
Fraises pour softforming  
Fresas para softforming

**Pag. 59**

Frese sagomate per lavorazione parquet  
Profile cutterheads for flooring production  
Profilfräser für Parkettbearbeitung  
Fraises profilées pour usinage parquet  
Fresas de perfil para producción pisos

**Pag. 60**

Frese a profilo  
Profile cutterheads  
Profilfräser  
Fraises profilées  
Fresas de perfil

**Pag. 61**

Frese per pantografo  
Router cutters  
Oberfräser  
Fraises à défoncer à queue cylindrique pour CN  
Fresas de mango para CN

**Pag. 96**

Frese per scanalature per pantografo  
Grooving router cutters  
Nutoberfräser  
Fraises à rainier à queue cylindrique  
Fresas de mango para ranurar

**Pag. 101**

Punte a forare  
Drill bits  
Bohrer  
Mèches de perçage  
Brocas

**Pag. 107**

Sistemi di fissaggio  
Tool holding systems  
Anschlag-system  
Système de fixation  
Elementos de sujecion



Informazioni tecniche  
Technical information  
Technische Informationen  
Informations techniques  
Informaciones técnicas

<b>Diametro lama Sawblade diameter Durchmesser sägeblätter Diamètre lame Diametro sierra</b>	
100 mm	23.000
125 mm	18.000
150 mm	14.500
180 mm	11.500
185 mm	11.000
200 mm	10.000
225 mm	8.500
250 mm	8.000
255 mm	7.800
280 mm	7.100
300 mm	6.500
320 mm	6.000
350 mm	5.500
380 mm	5.000
400 mm	4.700
430 mm	4.400
450 mm	4.200
500 mm	3.750
550 mm	3.400
600 mm	3.100
630 mm	2.950
650 mm	2.800
700 mm	2.600
730 mm	2.500
760 mm	2.400
800 mm	2.250



Forma dei denti  
Tooth shapes  
Zahnformen  
Forme des dents  
Forma de los dientes

MANCINI UTENSILI

FZ



TR-FZ-FA

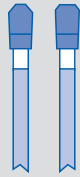

KON-FZ



FZ-FA



TR-TR



KON-WZ

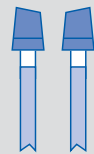

FZ-WFA



DA



HR-FA



HR-KON



WZ



DA-FZ



WZ-FA



ES



TR



TR-FZ



ES-L



ES-R



ES-FA-L



ES-FA-R



G5

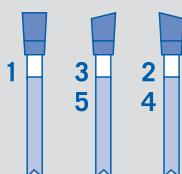

G6

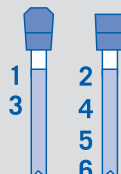



## Lame circolari

Circular saw blades

Kreissägeblätter

Lames circulaires

Sierras circulares

LSZ

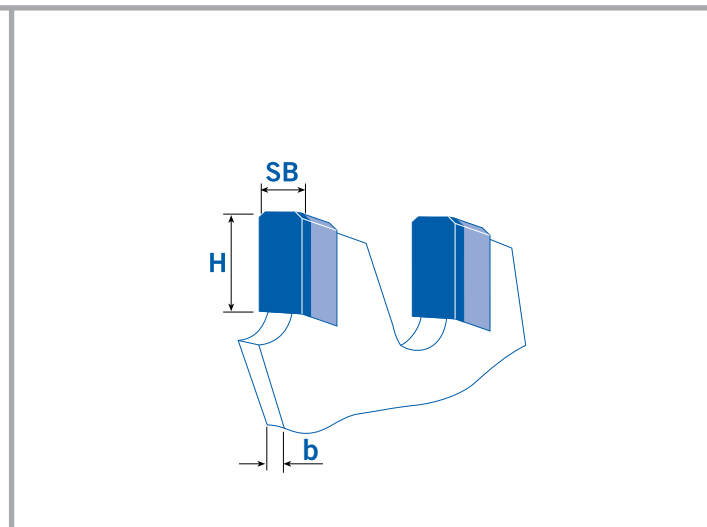
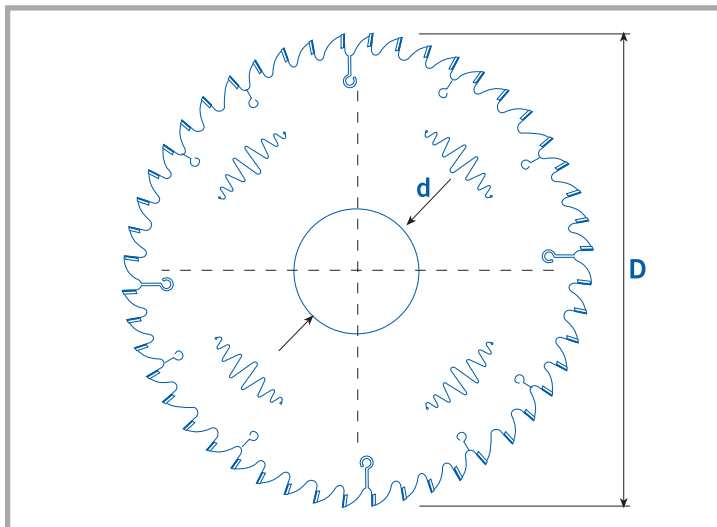
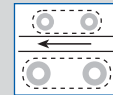

SB / b	H	 n/max	Prezzo Price Preis Prix Precio	Affilatura Sharpening Erodieren Affûtage Afilado
3,2 / 2,2	6	2.350 - 23.000	€ 20,21	€ 5,30
3,4 / 2,2	6	2.350 - 23.000	€ 21,47	€ 5,30
3,5 / 2,2	6	2.350 - 23.000	€ 22,11	€ 5,40
3,7 / 2,5	6	2.350 - 23.000	€ 23,37	€ 5,40
3,8 / 2,5	6	2.350 - 23.000	€ 24,00	€ 5,50
4,0 / 2,8	6	2.350 - 23.000	€ 25,26	€ 5,80
4,2 / 2,8	6	2.350 - 23.000	€ 26,53	€ 5,80
4,4 / 3,2	6	2.350 - 23.000	€ 27,79	€ 6,50
4,6 / 3,2	6	2.350 - 23.000	€ 29,05	€ 6,50
4,8 / 3,2	6	2.350 - 23.000	€ 30,32	€ 7,50
5,0 / 3,5	6	2.350 - 23.000	€ 31,58	€ 7,50
5,2 / 3,5	6	2.350 - 23.000	€ 32,84	€ 8,15
5,4 / 3,5	6	2.350 - 23.000	€ 34,11	€ 8,15
5,6 / 3,75	6	2.350 - 23.000	€ 35,37	€ 8,60
5,8 / 4	6	2.350 - 23.000	€ 36,63	€ 8,60
6,0 / 4	6	2.350 - 23.000	€ 37,89	€ 9,00

Prezzo al dente  
Price each tooth  
Preis pro Zahn  
Prix pour chaque dent  
Precio por diente

H=Dia 5 mm - 8%  
H=Dia 4 mm -12%

Lame con denti HR-FA  
Saw blades with HR-FA teeth  
Sägeblätter mit HR-FA Zähnen  
Lames avec dents HR-FA  
Sierras con dientes HR-FA

+ 20%

Prezzi validi per lame con minimo Z=24. Prezzi validi per lame con diametro massimo di 500 mm. Per lame con meno denti o con diametro superiore vi preghiamo di consultarci.

Above mentioned prices are valid for saw blades with a minimum of Z=24. Above mentioned prices are valid for saw blades with diameter up to 500 mm. For saw blades with less teeth or bigger diameter please ask for quotation.

Die Preise sind gültig für Sägeblätter mit min. Z=24. Die Preise sind gültig für Sägeblätter mit Durchmesser bis 500 mm. Für Sägeblätter mit weniger Zähnen oder mit größerem Durchmesser bitte anfragen.

Les prix sont valables pour lames avec min. Z=24. Les prix sont valables pour lames avec diamètre max. de 500 mm. Pour lames avec moins de dents ou diamètre supérieur nous vous prions de nous consulter.

Los precios son válidos para sierras circulares con minimo Z=24. Los precios son válidos para sierras circulares con diámetro máx. de 500 mm. Para sierras circulares con menos dientes o con un diámetro mayor rogamos nos consulten.



## Incisori Conici

Conical scoring saw blades

Ritzsägeblätter, konisch

Inciseurs coniques

Incisores cónicos

INC

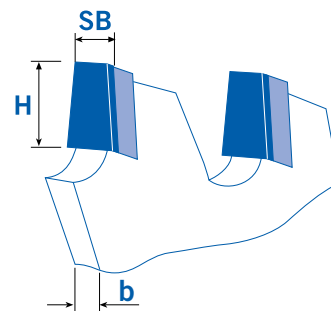
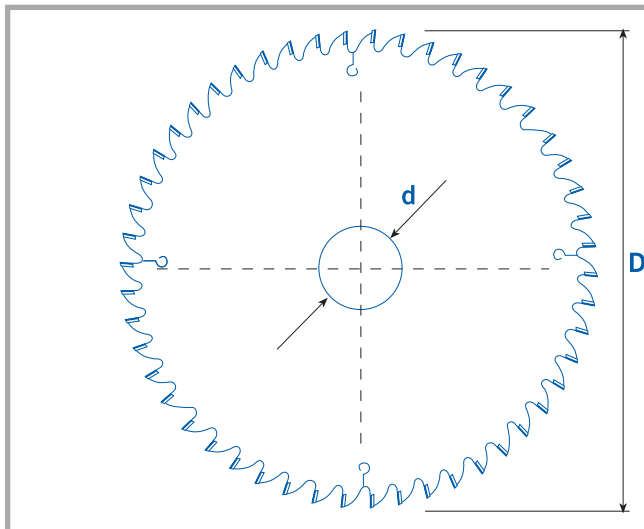
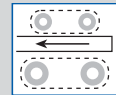

SB / b	H	 n/max	Prezzo Price Preis Prix Precio	Affilatura Sharpening Erodieren Affûtage Afilado
3,2 - 4,2 / 2,8	6	12.000 / 18.000	€ 23,80	€ 6,00
3,4 - 4,4 / 2,8	6	12.000 / 18.000	€ 25,30	€ 6,00
3,5 - 4,5 / 2,8	6	12.000 / 18.000	€ 26,10	€ 6,20
3,7 - 4,7 / 2,8	6	12.000 / 18.000	€ 27,50	€ 6,20
3,8 - 4,8 / 2,8	6	12.000 / 18.000	€ 28,30	€ 6,50
4,0 - 5,0 / 3,2	6	12.000 / 18.000	€ 29,70	€ 6,50
4,2 - 5,2 / 3,2	6	12.000 / 18.000	€ 31,30	€ 6,90
4,4 - 5,4 / 3,2	6	12.000 / 18.000	€ 32,70	€ 7,25
4,6 - 5,6 / 3,2	6	12.000 / 18.000	€ 34,20	€ 7,25
4,8 - 5,8 / 3,2	6	12.000 / 18.000	€ 35,70	€ 8,00
5,0 - 6,0 / 3,2	6	12.000 / 18.000	€ 37,20	€ 8,00
5,2 - 6,2 / 3,2	6	12.000 / 18.000	€ 38,60	€ 9,00
5,4 - 6,4 / 3,2	6	12.000 / 18.000	€ 40,20	€ 9,00
5,6 - 6,6 / 3,2	6	12.000 / 18.000	€ 41,60	€ 9,60
5,8 - 6,8 / 3,2	6	12.000 / 18.000	€ 43,10	€ 9,60
6,0 - 7,0 / 3,2	6	12.000 / 18.000	€ 44,60	€ 10,50

Prezzo al dente  
Price each tooth  
Preis pro Zahn  
Prix pour chaque dent  
Precio por diente

$f_z$ mm	 m/1'
0,05 - 0,15	10 - 20

D	 n/max
100 - 120	19.000
125 - 160	14.000
161 - 180	12.700
181 - 200	10.900
215 - 300	7.500

Incisori con denti HR-KON  
Scoring saw blades with HR-KON teeth  
Ritzsägeblätter mit HR-KON Zähnen  
Inciseurs avec dents HR-KON  
Incisores con dientes HR-KON

+20%

H=Dia 5 mm - 8%

H=Dia 4 mm -12%

Prezzi validi per incisori con minimo Z=24. Per incisori con meno denti vi preghiamo di consultarci.

Above mentioned prices are valid for scoring saw blades with a minimum of Z=24. For scoring saw blades with less teeth please ask for quotation.

Die Preise sind gültig für Ritzsägeblätter mit min. Z=24. Für Ritzsägeblätter mit weniger Zähnen bitte anfragen.

Les prix sont valables pour inciseurs avec min. Z=24. Pour inciseurs avec moins de dents nous vous prions de nous consulter.

Los precios son válidos para incisores con minimo Z=24. Para incisores con menos dientes rogamos nos consulten.



## Incisori regolabili

Split scoring saw blades

Ritzsägeblätter, verstellbar

Inciseurs extensibles

Incisores regulables

**INR**

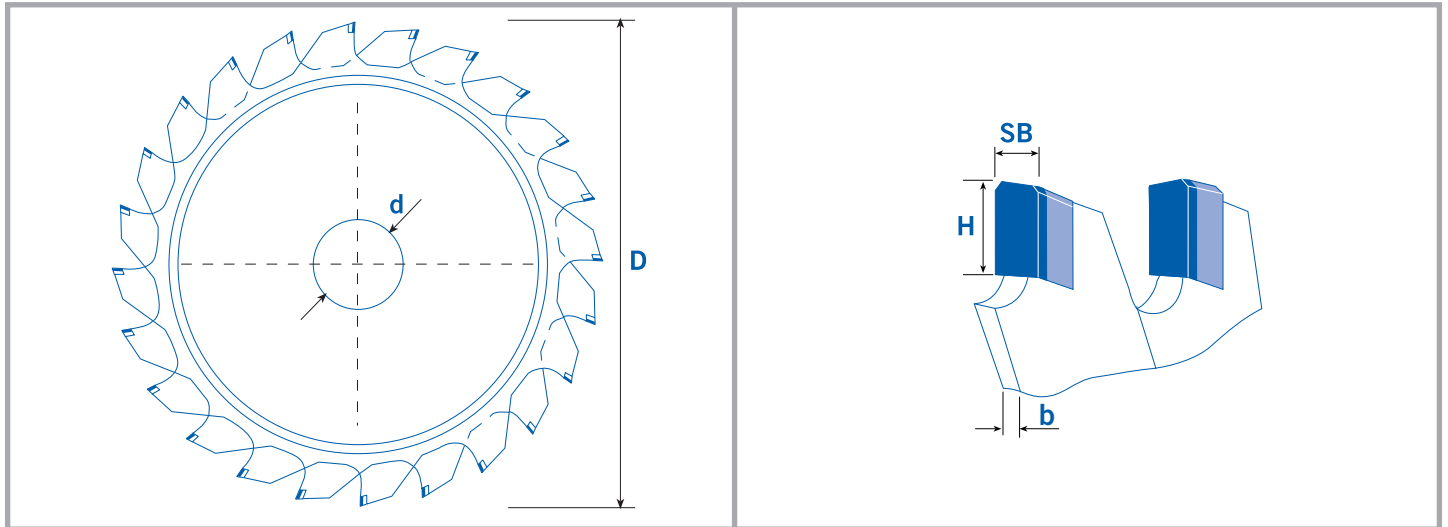
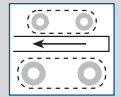

SB / b	Z	H	Prezzo Price Preis Prix Precio	Affilatura Sharpening Erodieren Affûtage Afilado
2,8 - 3,6 / 2,2	10 + 10	6	€ 500,00	€ 180,00
2,8 - 3,6 / 2,2	12 + 12	6	€ 600,00	€ 215,00
2,8 - 3,6 / 2,2	16 + 16	6	€ 760,00	€ 250,00
2,8 - 3,6 / 2,2	18 + 18	6	€ 855,00	€ 300,00
4,0 - 5,0 / 2,8	10 + 10	6	€ 650,00	€ 200,00
4,0 - 5,0 / 2,8	12 + 12	6	€ 780,00	€ 240,00
4,0 - 5,0 / 2,8	16 + 16	6	€ 990,00	€ 280,00
4,0 - 5,0 / 2,8	18 + 18	6	€ 1.125,00	€ 340,00
4,0 - 5,0 / 2,8	30 + 30	6	€ 1.725,00	€ 450,00

H=Dia 5 mm - 8%  
H=Dia 4 mm -12%

Incisori con corpo in acciaio speciale  
Scoring saw blades with special steel body  
Ritzsägeblätter mit Grundkörper aus Spezialstahl  
Inciseurs avec corps en acier spécial  
Incisores con cuerpo de acero especial

**+ 50%**

$f_z$ mm
0,05 - 0,15

$\leftarrow$ m/1'
10 - 16

D	$\frac{n}{\text{max}}$
100 - 120	15.000
125 - 160	10.00
161 - 180	8.000
181 - 210	6.000
220 - 300	4.000



## Lame per materiali duri e abrasivi

Saw blades for hard and abrasive materials

Sägeblätter für harten und abrasiven Materialien

Lames pour matériaux durs et abrasifs

Sierras para materiales duros y abrasivos

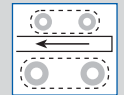

**LCA**

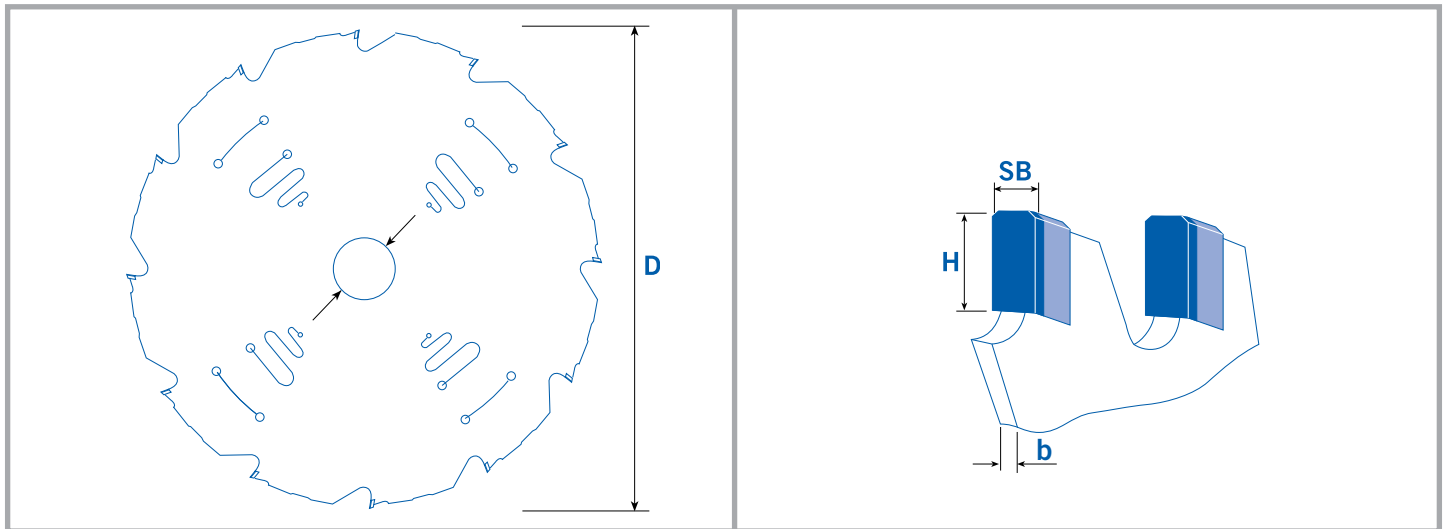

D	SB	Z	H	 n/max	Prezzo Price Preis Prix Precio	Affilatura Sharpening Erodieren Affûtage Afilado
160	2,4 / 1,6	4	5	15.000	€ 180,00	€ 80,00
160	2,4 / 1,6	8	5	15.000	€ 360,00	€ 135,00
190	2,4 / 1,6	4	5	11.000	€ 180,00	€ 80,00
190	2,4 / 1,6	8	5	11.000	€ 360,00	€ 135,00
200	2,4 / 1,6	4	5	10.000	€ 180,00	€ 80,00
200	2,4 / 1,6	8	5	10.000	€ 360,00	€ 135,00
216	2,4 / 1,6	8	5	10000	€ 360,00	€ 135,00
216	2,4 / 1,6	12	5	10.000	€ 540,00	€ 160,00
230	2,4 / 1,6	6	5	8.000	€ 230,00	€ 100,00
230	2,4 / 1,6	12	5	8.000	€ 540,00	€ 160,00
250	2,4 / 1,6	6	5	8.000	€ 230,00	€ 100,00
250	2,4 / 1,6	12	5	8.000	€ 540,00	€ 160,00
300	2,4 / 1,6	12	5	6.500	€ 540,00	€ 160,00
300	2,4 / 1,6	20	5	6.500	€ 900,00	€ 210,00
400	3,8 / 2,8	16	5	4.700	€ 800,00	€ 250,00
450	3,8 / 2,8	16	5	4.200	€ 800,00	€ 250,00
500	3,8 / 2,8	16	5	3.750	€ 820,00	€ 250,00

$f_z$  mm

sawing 0,03 - 0,07

cutting 0,5 - 1

$V_c$

20 / 40 m/s



Informazioni tecniche  
Technical information  
Technische Informationen  
Informations techniques  
Informaciones técnicas

**Informazioni valori "Fz" per articoli TRP - TRN - TRG - TRR - TRD - TRS**

**Information values "Fz" for art. TRP - TRN - TRG - TRR - TRD - TRS**

**Informationen werte "Fz" für el. TRP - TRN - TRG - TRR - TRD - TRS**

**Informations valeurs "Fz" pour art. TRP - TRN - TRG - TRR - TRD - TRS**

**Informaciones valores "Fz" para art. TRP - TRN - TRG - TRR - TRD - TRS**

Legni stratificati per lungo vena Laminated panels with grain Vene entlang geschichtet Stratifiés le long de la veine Estratificado a largo de la vena	0,30 - 0,40	Truciolari e fibrosi Chipboard and agglomerate raw Spanplatten un fibrose Panneaux de particules et de la fibrose Aglomerado y la fibrosis	
Legni stratificati per traverso vena Laminated panels across grain Schichtgreif Transversal stratifie Transversal estratificada	0,15 - 0,25	Grezzo Raw Roh Bruts Crudo	0,40 - 0,50
		Impiall. Venereed Furniert Plaqués Chapeada	0,05 - 0,10
		Nob. plast. Melamine plastic Melamine-Kunststoff Melamine plastique Plastico de melamina	0,10 - 0,15
		Nob. carta Laminated with paper Mit paper kaschiert Stratifié avec du papier Laminado con papel	0,05 - 0,10





**TRP**

## Truciolatori monoblocco con angolo di taglio positivo

Compact hoggers with positive hook angle

Kompaktzerspaner, positiver Spanwinkel

Déchiqueteurs compacts avec angle de coupe positif

Trituradores compactos con ángulo de ataque positivo

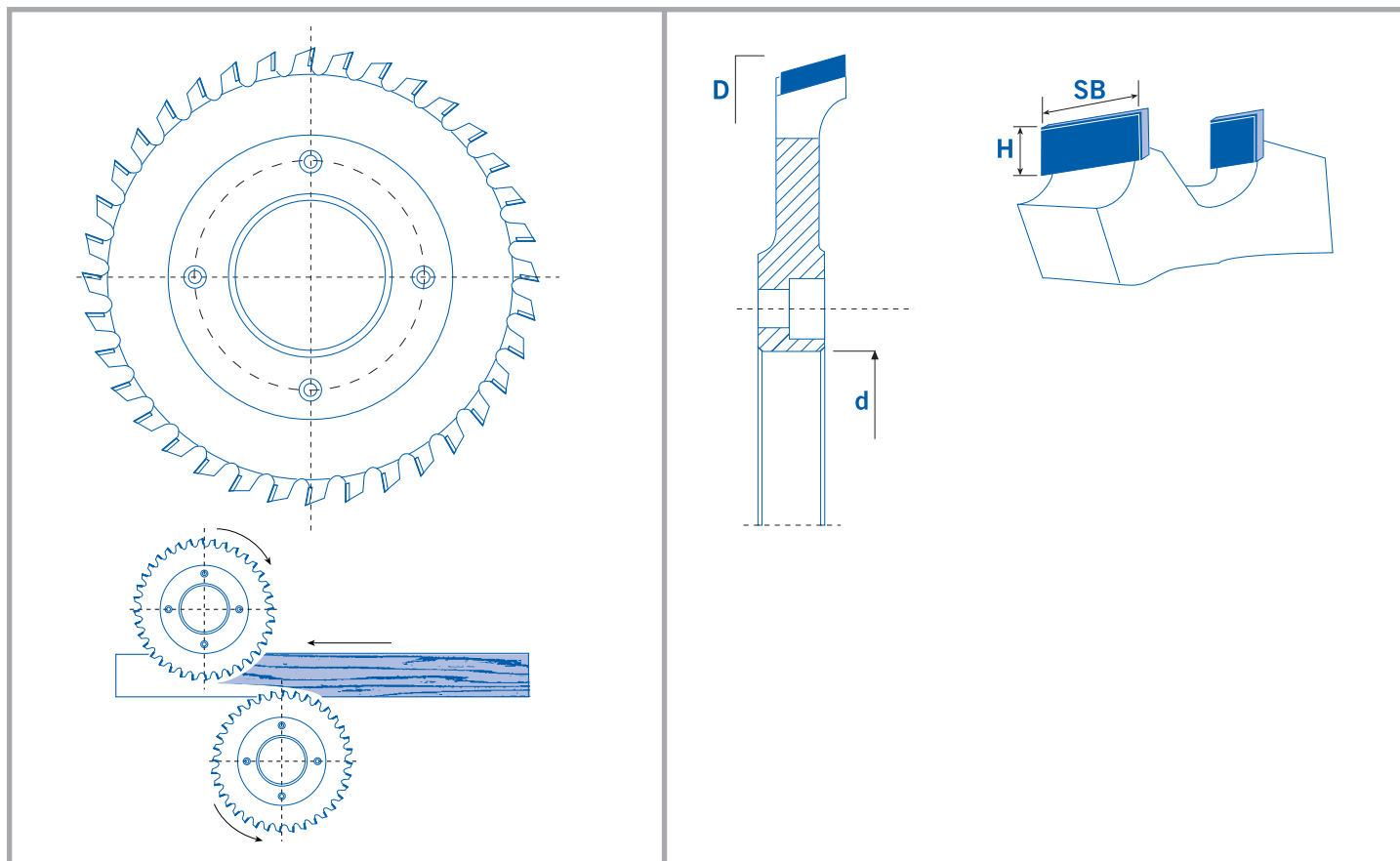
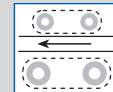

D	SB	Z	H	← m/1' →		n/max	Prezzo Price Preis Prix Precio	Affilatura Sharpening Erodieren Affûtage Afilado
				vi/t	vt/t			
200 - 250	10 - 20	30 + 6 (+ 6HW)	6	20	32	7.200	€ 1.500,00	€ 470,00
200 - 250	10 - 20	36 + 6 (+ 6HW)	6	25	40	7.200	€ 1.700,00	€ 560,00
						7.200		
250	10 - 20	42 + 6 (+ 6HW)	6	27,5	45	7.200	€ 1.900,00	€ 650,00
250	10 - 20	48 + 6 (+ 6HW)	6	30	50	7.200	€ 2.050,00	€ 740,00
250	10 - 20	60 + 6 (+ 6HW)	6	40	60	7.200	€ 2.400,00	€ 860,00

Disponibili per ogni tipo di mozzo.

Available for any type of sleeve.

Verfügbar für jede Büchse.

Disponibles pour tous types de manchons.

Disponibles para todos los elementos de sujeción.



## Truciolatori monoblocco con angolo di taglio negativo

Compact hoggers with negative hook angle

Kompaktzerspaner, negativer Spanwinkel

Déchiqueteurs compacts avec angle de coupe négatif

Trituradores compactos con ángulo de ataque negativo

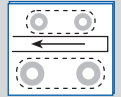

**TRN**

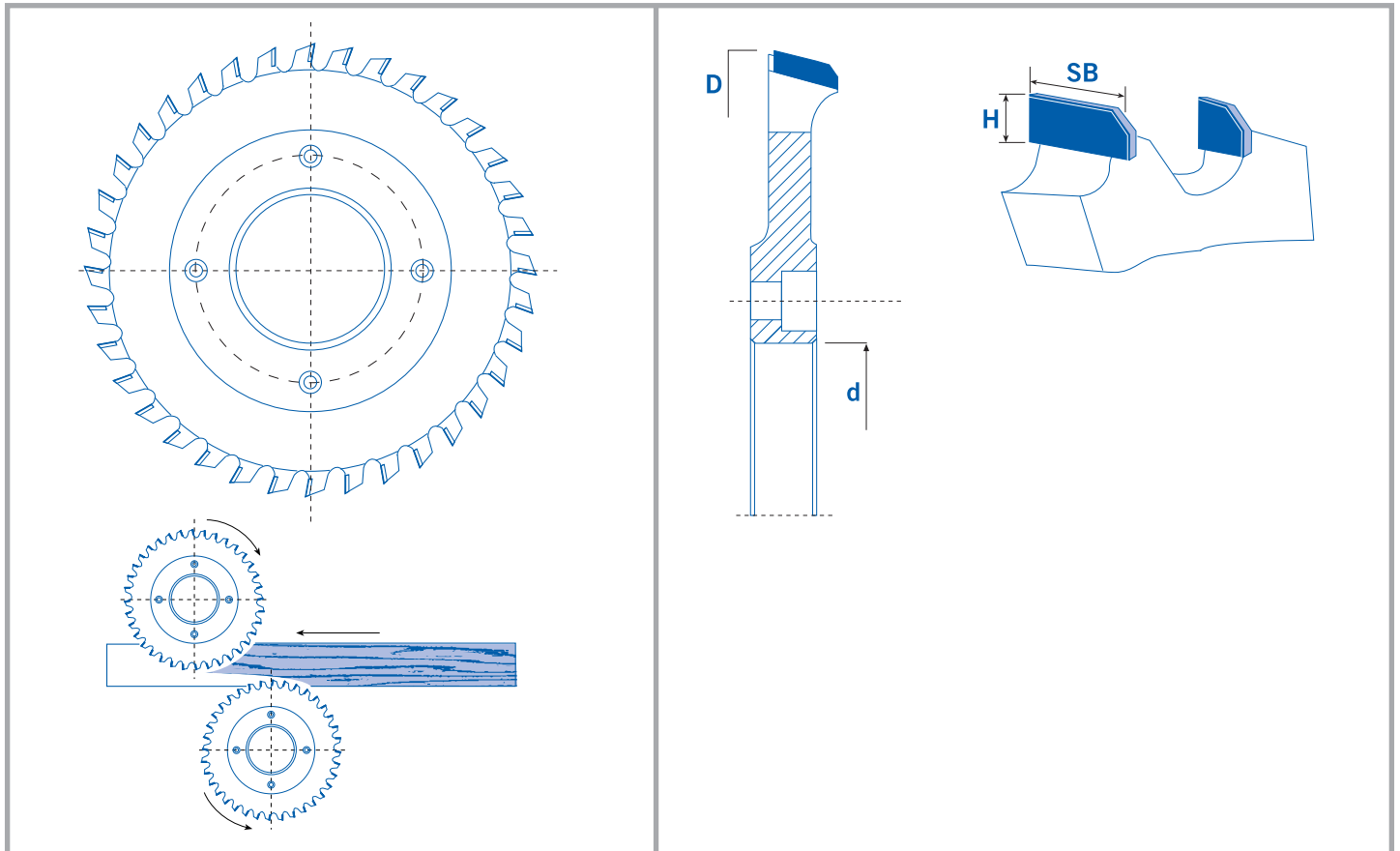

D	SB	Z	H	← m/1'		⊖ n/max ⊕		Prezzo Price Preis Prix Precio	Affilatura Sharpening Erodieren Affûtage Afilado
				vi/t	vt/t				
215 - 250	15	36 (30 + 6)	6	20	32	6.000	7.200	€ 1.600,00	€ 420,00
215 - 250	15	42 (36 + 6)	6	25	40	6.000	7.200	€ 1.800,00	€ 500,00
215 - 250	15	48 (42 + 6)	6	27,5	45	6.000	7.200	€ 1.950,00	€ 580,00
215 - 250	15	54 (48 + 6)	6	30	50	6.000	7.200	€ 2.150,00	€ 650,00
250	14,5 - 23	12 + 6 + 6	5		30		7.200	€ 1.840,00	€ 400,00
250	14,5 - 23	16 + 8 + 4	5		30		7.200	€ 2.150,00	€ 450,00
250	14,5 - 23	20 + 10 + 5	5		35		7.200	€ 2.600,00	€ 560,00
250	14,5 - 23	24 + 12 + 6	5		40		7.200	€ 3.100,00	€ 630,00
250	14,5 - 23	28 + 14 + 7	5		50		7.200	€ 3.600,00	€ 750,00
250	14,5 - 23	32 + 16 + 8	5		60		7.200	€ 4.200,00	€ 840,00

Disponibili per ogni tipo di mozzo. Available for any type of sleeve. Verfügbar für jede Büchse.  
Disponibles pour tous types de manchons. Disponibles para todos los elementos de sujeción.



**TRG**

**Truciolatori monoblocco ad alto rendimento con angolo di taglio negativo**

**High performance compact hoggers with negative hook angle**

**Hochleistungskompaktzerspaner negativer Spanwinkel**

**Déchiqueteurs compacts à haut rendement avec angle de coupe négatif**

**Trituradores compactos de alto rendimiento con ángulo de ataque negativo**

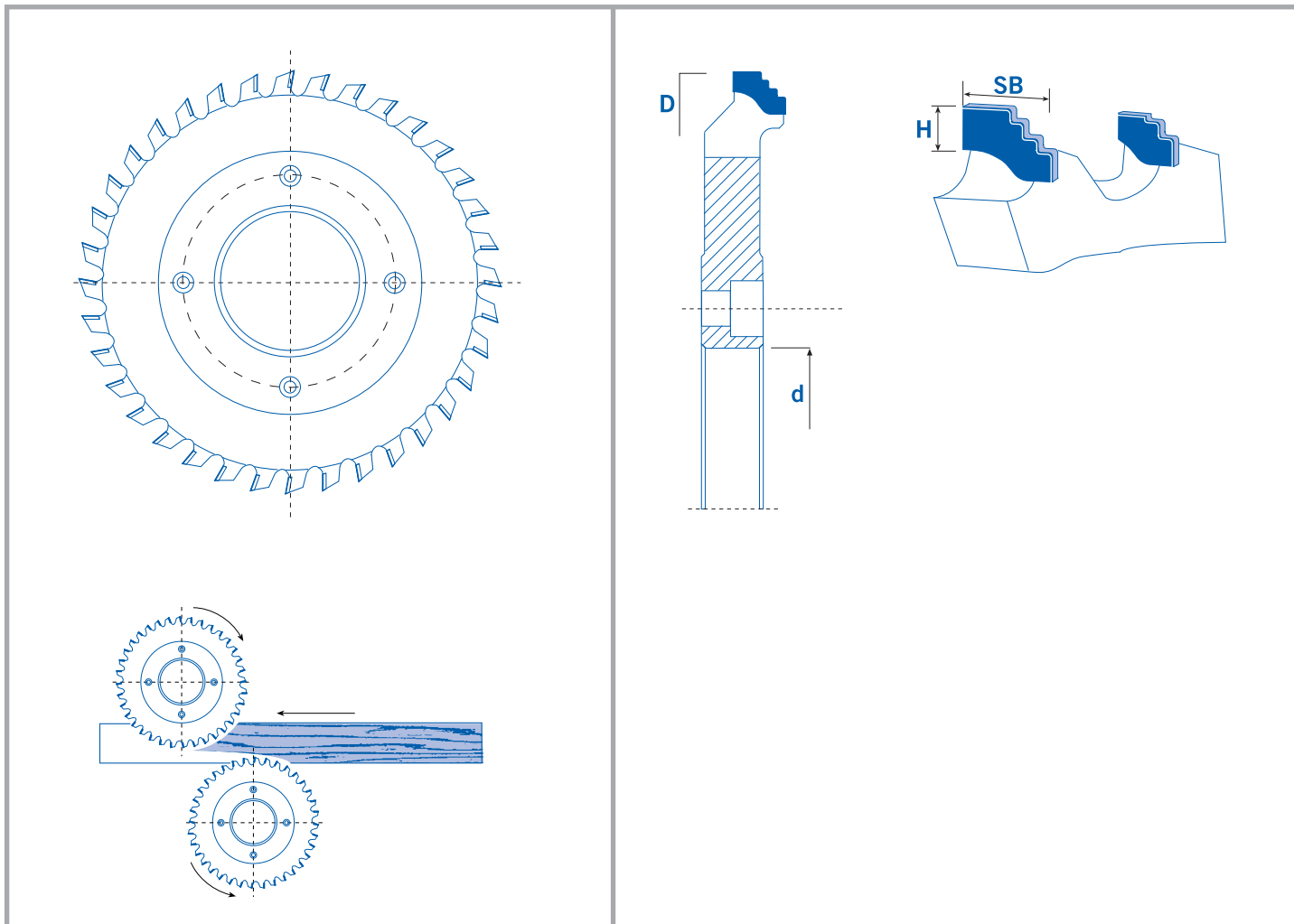
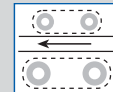

D	SB	Z	H	← m/1'	 n/max	Prezzo Price Preis Prix Precio	Affilatura Sharpening Erodieren Affûtage Afilado
215 - 250	13,5	30 (24 + 6)	6	35	7.200	€ 2.200,00	€ 555,00
215 - 250	13,5	36 (30 + 6)	6	45	7.200	€ 2.600,00	€ 660,00
230 - 250	13,5	42 (36 + 6)	6	50	7.200	€ 3.000,00	€ 800,00
250	13,5	48 (42 + 6)	6	60	7.200	€ 3.500,00	€ 900,00

Disponibili per ogni tipo di mozzo.

Available for any type of sleeve.

Verfügbar für jede Büchse.

Disponibles pour tous types de manchons.

Disponibles para todos los elementos de sujeción.



## Truciolatori monoblocco raggiati

Compact hoggers with round cut

Radius-Kompaktzerspaner

Déchiqueteurs compacts radiés

Trituradores compactos con corte redondo

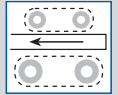

# TRR

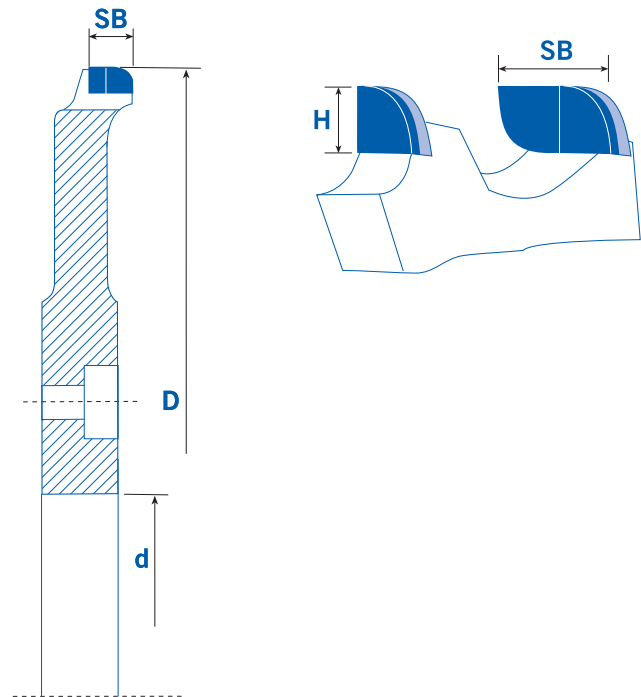
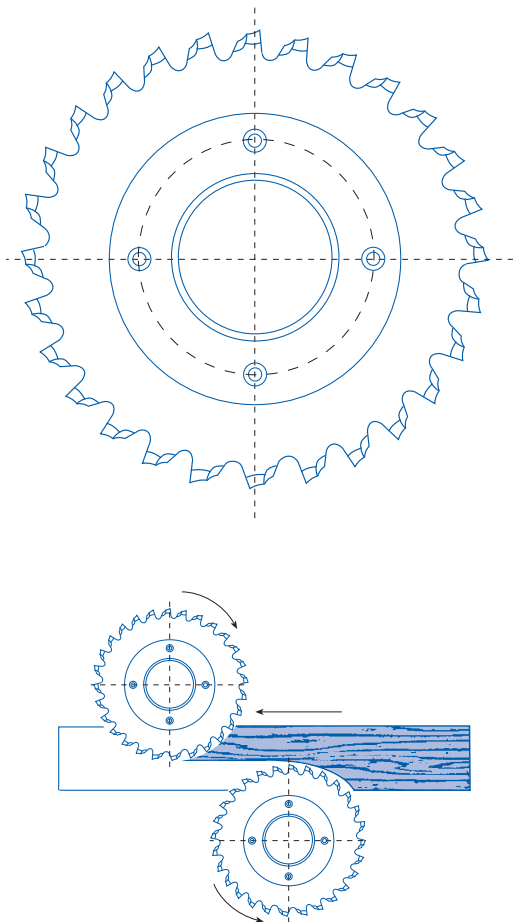

D	SB	Z	H	 m/1'	 n/max ◊	Prezzo Price Preis Prix Precio	Affilatura Sharpening Erodieren Affûtage Afilado
210 - 250	15	20 + 4	7,5	20	7.200	€ 1.800,00	€ 380,00
210 - 250	15	24 + 4	7,5	25	7.200	€ 2.100,00	€ 470,00
210 - 250	13	28 + 4	7,5	30	7.200	€ 2.300,00	€ 540,00
210 - 250	15	32 + 8	7,5	35	7.200	€ 2.850,00	€ 650,00

Disponibili per ogni tipo di mozzo.

Available for any type of sleeve.

Verfügbar für jede Büchse.

Disponibles pour tous types de manchons.

Disponibles para todos los elementos de sujeción.



**TRD**

**Truciolatori con lama DP  
e con settori dentati in HW**

**Hoggers with PCD saw blade  
and HW segments**

**Segmentzerspaner mit PKD-Sägeblatt  
und HW-Segmenten**

**Déchiqueteurs avec lame DP  
et segments HW**

**Trituradores con sierra en DP  
y con segmentos en HW**

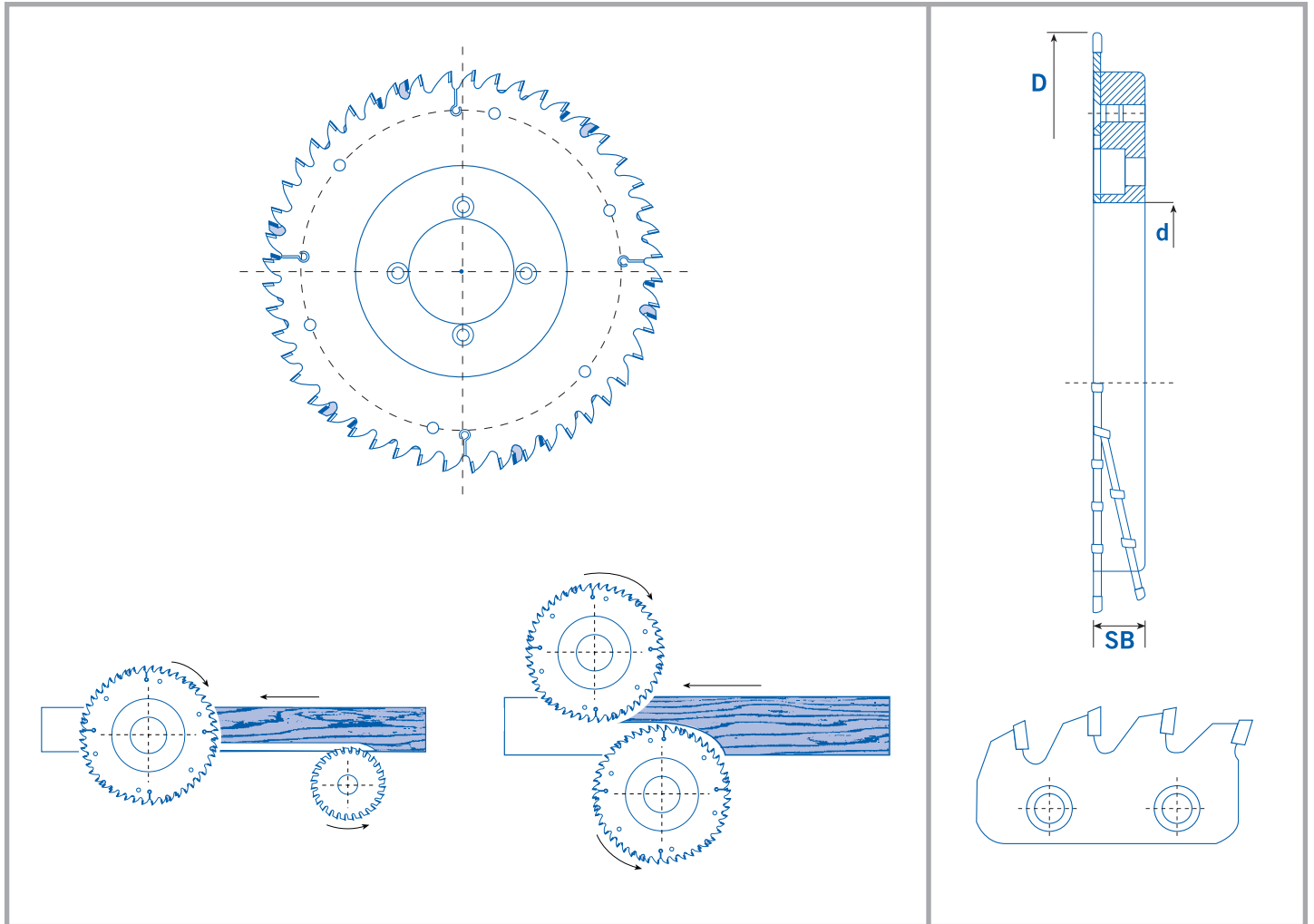
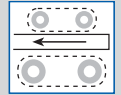

D	SB	Z	H	← m/1' →		 n/max	Prezzo Price Preis Prix Precio	Affilatura Sharpening Erodieren Affûtage Afilado
				vi/t	vt/t			
205	18	36 (+ 4 x 4 HW)	6	25	40	7.200	€ 1.700,00	€ 350,00
205	18	48 (+ 4 x 4 HW)	6	30	50	7.200	€ 2.300,00	€ 470,00
255	18	48 (+ 6 x 4 HW)	6	35	50	7.200	€ 2.420,00	€ 500,00
255	18	60 (+ 6 x 4 HW)	6	40	60	7.200	€ 2.980,00	€ 620,00

Disponibili per ogni tipo di mozzo.

Available for any type of sleeve.

Verfügbar für jede Büchse.

Disponibles pour tous types de manchons.

Disponibles para todos los elementos de sujeción.



## Lame DP per truciolatori

PCD saw blades for hoggers

PKD-Sägeblätter für Zerspaner

Lames DP pour déchiqueteurs

Sierras en DP para trituradores

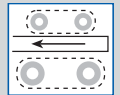

# LTR

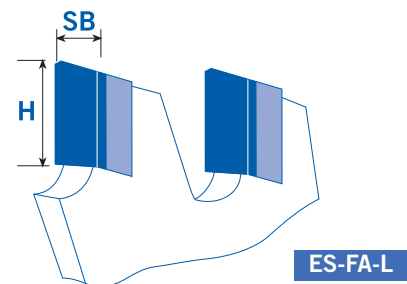
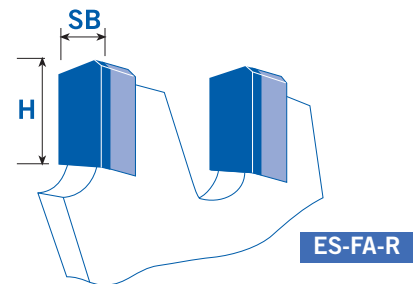
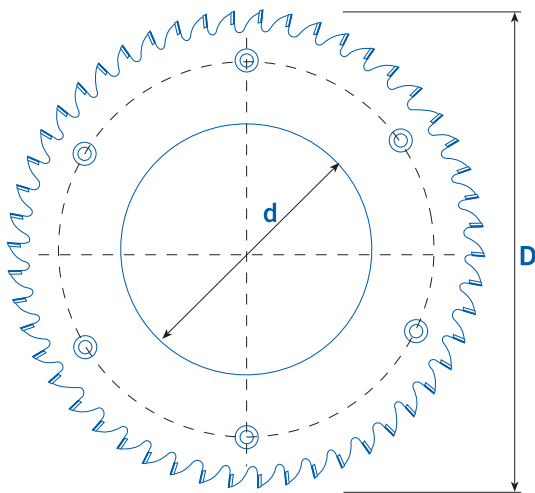

D	SB	Z	H	Prezzo Price Preis Prix Precio	Affilatura Sharpening Erodieren Affûtage Afilado
205 - 255	4,1	36	6	€ 935,00	€ 215,00
205 - 255	4,1	48	6	€ 1.250,00	€ 285,00
255	4,1	60	6	€ 1.550,00	€ 360,00

H=Dia 5 mm - 8%

H=Dia 4 mm -12%



## Settori dentati in DP / HW per truciolatori

PCD / HW segments for hoggers

PKD / HW-Segmente für Segmentzerspaner

Segments DP / HW pour déchiqueteurs

Segmentos en DP / HW para trituradores

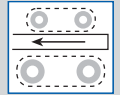

# STD

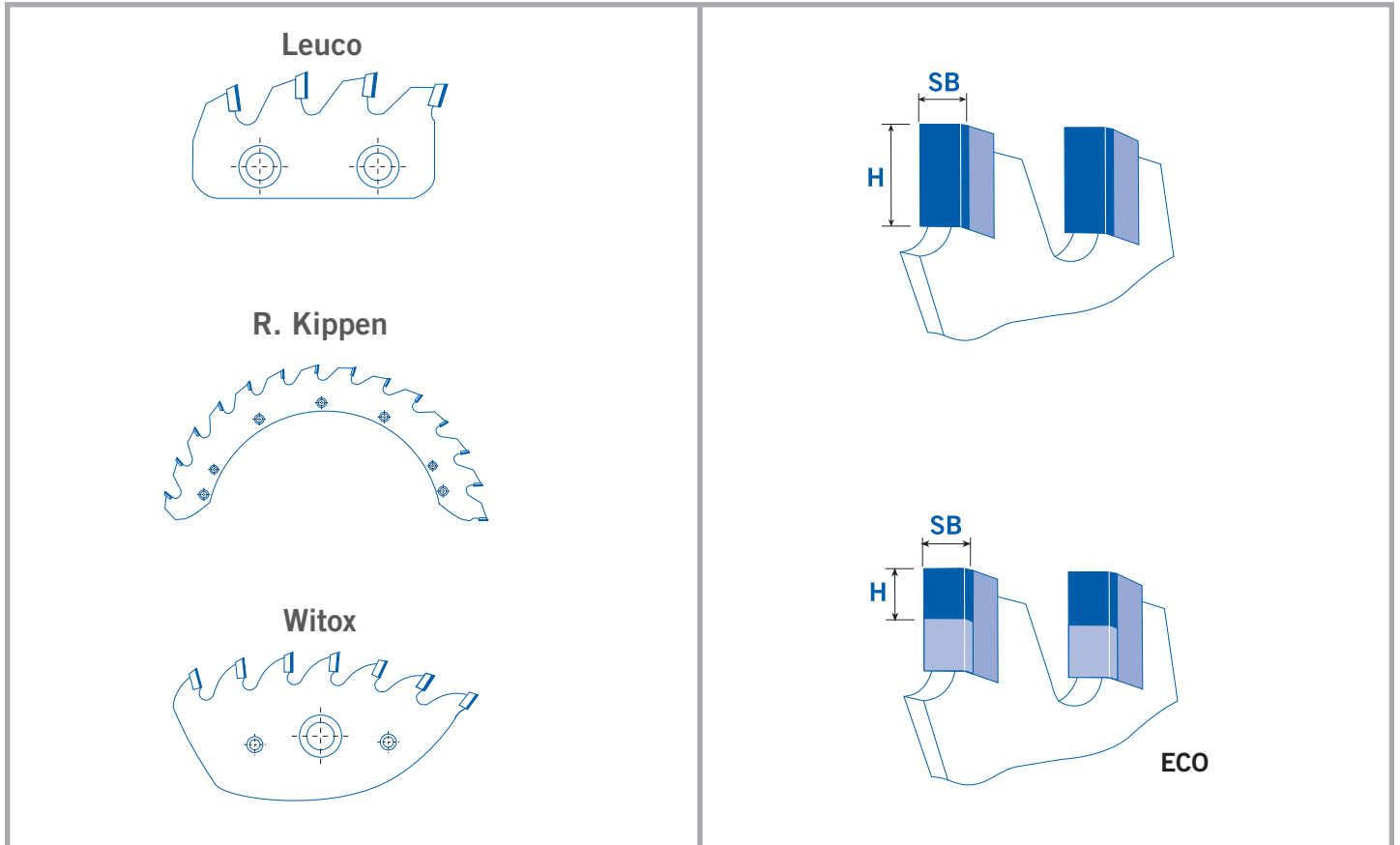

	D	SB	Z	H	Prezzo Price Preis Prix Precio	Affilatura Sharpening Erodieren Affûtage Afilado
Leuco	205 - 255	5	4 DP	9	€ 240,00	€ 100,00
Leuco	205 - 255	5	3 DP + 1 HW	9	€ 180,00	€ 75,00
Leuco	205 - 255	5	2 DP + 2 HW	9	€ 150,00	€ 50,00
Leuco	205 - 255	5	1 DP + 3 HW	9	€ 100,00	€ 25,00
R. Kippen	205	5	2 DP + 10 HW	9	€ 240,00	€ 65,00
R. Kippen	205	5	12 DP	9	€ 730,00	€ 240,00
R. Kippen	250	5	2 DP + 12 HW	9	€ 280,00	€ 75,00
R. Kippen	250	5	14 DP	9	€ 850,00	€ 280,00
Witox	250	5	4 DP + 3 HW	9	€ 320,00	€ 115,00
Witox	250	5	7 DP	9	€ 435,00	€ 175,00

ECO H=Dia 5 mm -25%



## Settori dentati in HW per truciolatori

HW segments for hoggers

HW-Segmente für Segmentzerspaner

Segments HW pour déchiqueteurs

Segmentos en HW para trituradores

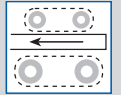

# STH

Leuco

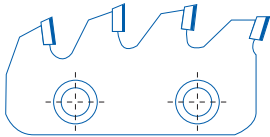

R. Kippen

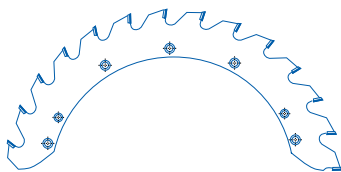

Witox

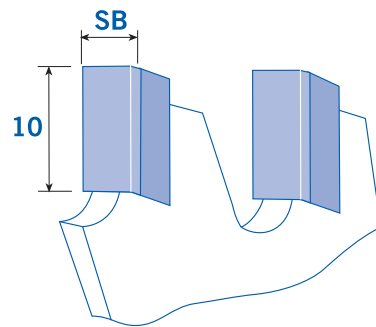
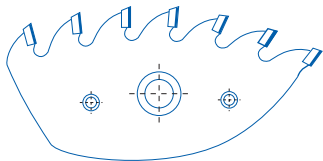

	D	SB	Z	Prezzo Price Preis Prix Precio	Affilatura Sharpening Erodieren Affûtage Afilado
Leuco	205 - 255	5	4 HW	€ 60,00	€ 12,50
R. Kippen	205	5	14 HW	€ 120,00	€ 25,00
Witox	250	5	7 HW	€ 90,00	€ 15,00





**TRS**

**Truciolatori a settori per preforming**

**Segment hoggers for preforming**

**Segmentzerspaner für Preforming**

**Déchiqueteurs à segments pour preforming**

**Trituradores con segmentos para preforming**

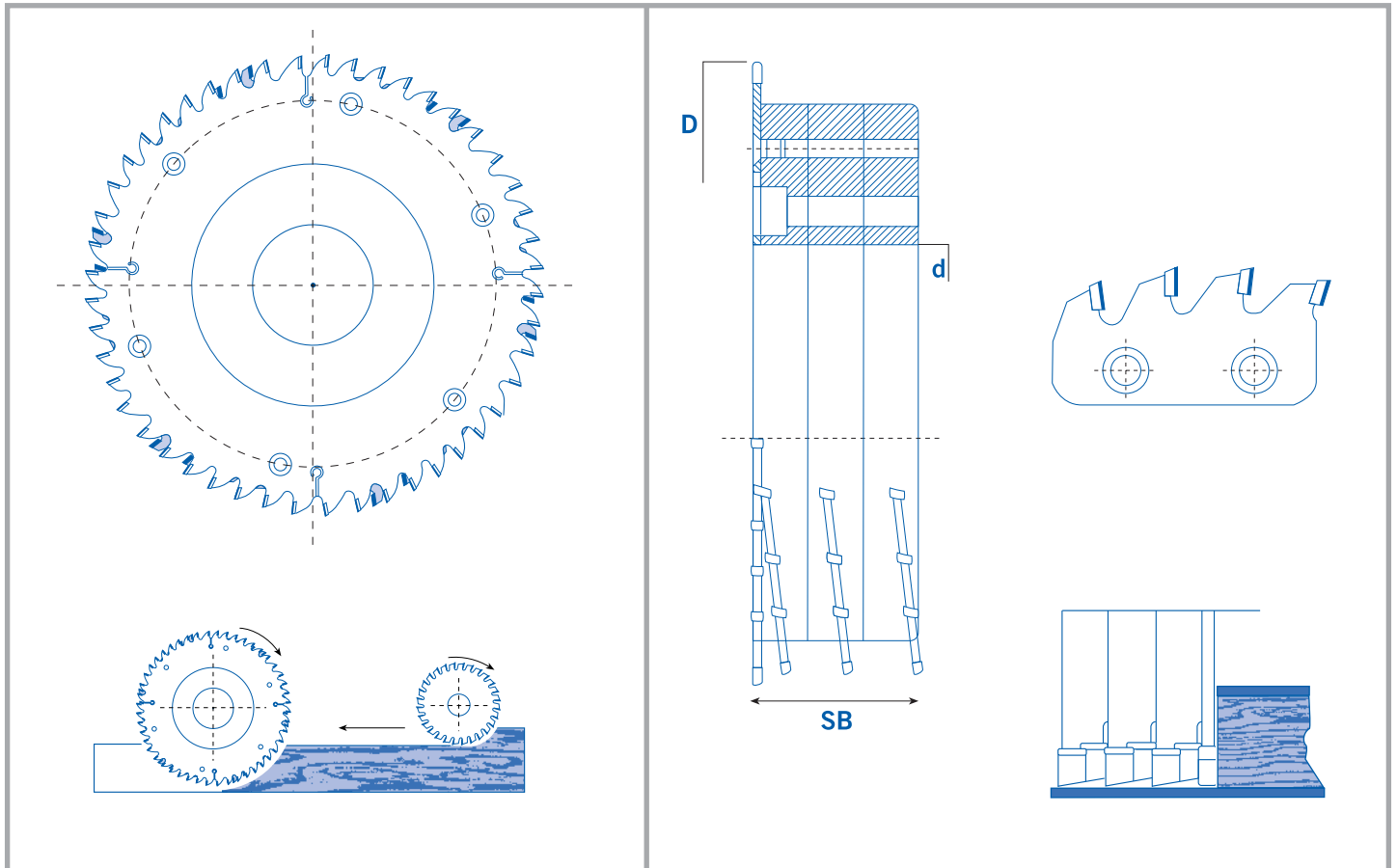
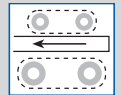

D	SB	Z	← m/1'	 n/max	Prezzo Price Preis Prix Precio	Affilatura Sharpening Erodieren Affûtage Afilado
205	35	36 DP + 32 DP	35 / 40	10.000	€ 3.400,00	€ 660,00
205	50	36 DP + 48 DP	45 / 50	10.000	€ 4.200,00	€ 770,00

Truciolatore a settori  
Hogger with segments  
Segmentzerspaner  
Déchiqueteur à segments  
Triturador con segmentos

H=Dia 9 mm

Lama  
Saw blade  
Sägeblatt  
Lame  
Sierra

H=Dia 6 mm

Truciolatori disponibili con corpo monoblocco.  
Hoggers available with compact body.  
Zerspaner verfügbar mit Tragkörper einteilig.  
Déchiqueteurs disponibles avec corps monobloc.  
Trituradores disponibles en cuerpo compacto.

**ACCESSORI / SPARE PARTS / ZUBEHÖR / ACCESSOIRES / ACCESORIOS:**

Page / Pages / Seiten / Pages / Páginas **20-22**



Informazioni tecniche  
Technical information  
Technische Informationen  
Informations techniques  
Informaciones técnicas

**Valori indicativi per l'avanzamento del dente "Fz" per articoli RTF - RTR - ANF - ANR**

**Indicative values for feeding for teeth "Fz" for art. RTF - RTR - ANF - ANR**

**Werte für vorschub pro zahn "Fz" für el. RTF - RTR - ANF - ANR**

**Valeurs indicatives pour l'avance par dent "Fz" pour art. RTF - RTR - ANF - ANR**

**Valores indicativos por los avance de diente "Fz" para art. RTF - RTR - ANF - ANR**

Truciolari e stratificati Chipboard and laminated Spanplatte und Verbundplatten Panneaux de particules et stratifiés Aglomerado y laminados		Materie plastiche Plastics Plastics Plastiques Plástica	
Grezzi Raw Roh Bruts Crudo	0,70 - 0,90 mm	Fibre sintetiche (GFK) Fiber reinforced (GFK) Verstärktenkunststoffe (GFK) Panneaux renforcé (GFK) Plastico reforzado	0,05 - 0,10 mm
Impiallacciati Venereed Furniert Plaqués Chapeada	0,40 - 0,60 mm	Polimero legato Polimer board Polymere Polymères Polimeros	0,60 - 0,80 mm
Nob. plastico Melamine plastic Melamine kunststoff Melamine plastique Plastico de melamina	0,50 - 0,70 mm		
Nob. carta Laminated with paper Mit papier kaschiert Stratifié avec du papier Laminado con papel	0,20 - 0,30 mm		



## Frese a rettificare per bordatrici

Jointing cutterheads for edge banding machines

Fügefräser für Kantenbearbeitungsmaschinen

Fraises à rectifier pour plaqueuses de chants

Fresas para rectificar con encoladoras de cantos

**RTF**

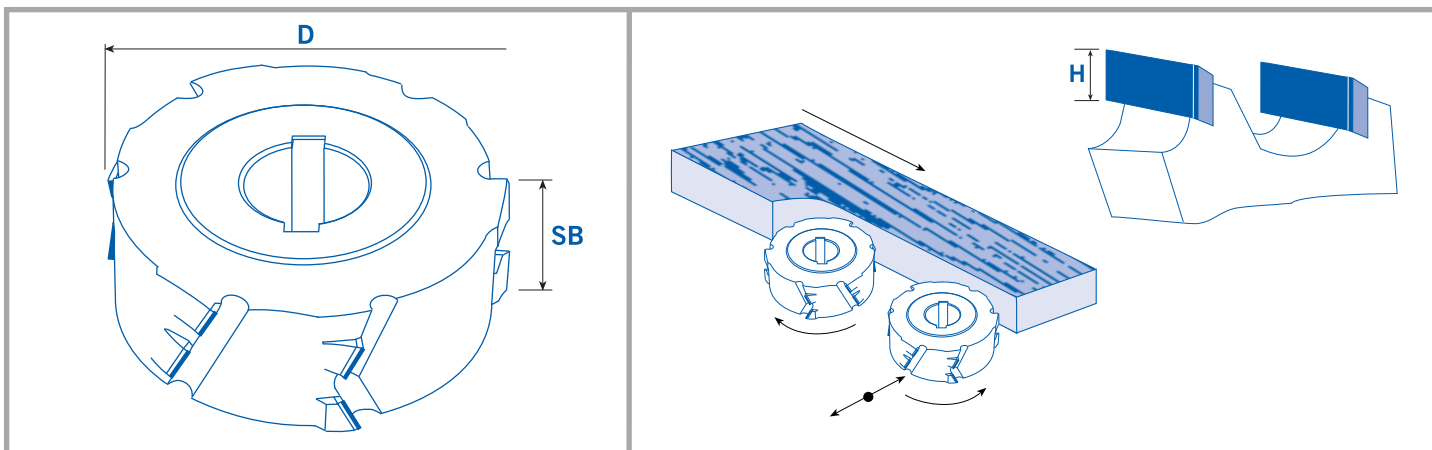
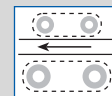

D	SB	Z	H	← m/1'	 n/max	Prezzo Price Preis Prix Precio	Affilatura Sharpening Erodieren Affûtage Afilado
50 - 125	28	2 + 2	5	18 / 25	18.000 / 15.000	€ 470,00	€ 140,00
50 - 125	35	2 + 2	5	18 / 25	18.000 / 15.000	€ 570,00	€ 190,00
50 - 125	43	2 + 2	5	18 / 25	18.000 / 15.000	€ 665,00	€ 230,00
50 - 125	48	2 + 2	5	18 / 25	18.000 / 15.000	€ 705,00	€ 250,00
50 - 125	56	2 + 2	5	18 / 25	18.000 / 15.000	€ 808,00	€ 300,00
50 - 125	63	2 + 2	5	18 / 25	18.000 / 15.000	€ 860,00	€ 315,00
50 - 125	28	3 + 3	5	18 / 25	18.000 / 15.000	€ 616,00	€ 210,00
50 - 125	35	3 + 3	5	18 / 25	18.000 / 15.000	€ 760,00	€ 260,00
50 - 125	43	3 + 3	5	18 / 25	18.000 / 15.000	€ 905,00	€ 290,00
50 - 125	48	3 + 3	5	18 / 25	18.000 / 15.000	€ 965,00	€ 315,00
50 - 125	56	3 + 3	5	18 / 25	18.000 / 15.000	€ 1.120,00	€ 380,00
50 - 125	63	3 + 3	5	18 / 25	18.000 / 15.000	€ 1.190,00	€ 400,00
100 - 125	28	4 + 4	5	25 / 30	15.000	€ 760,00	€ 290,00
100 - 125	35	4 + 4	5	25 / 30	15.000	€ 950,00	€ 340,00
100 - 125	43	4 + 4	5	25 / 30	15.000	€ 1.144,00	€ 380,00
100 - 125	48	4 + 4	5	25 / 30	15.000	€ 1.225,00	€ 420,00
100 - 125	56	4 + 4	5	25 / 30	15.000	€ 1.430,00	€ 500,00
100 - 125	63	4 + 4	5	25 / 30	15.000	€ 1.530,00	€ 535,00

H=Dia 6 mm + 8%  
H=Dia 4 mm - 8%  
H=Dia 3 mm -12%

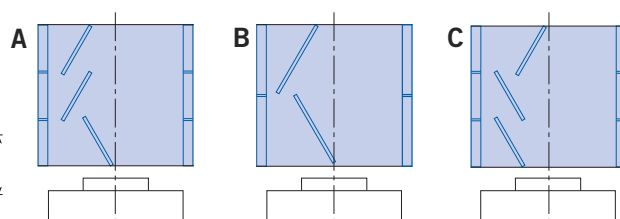
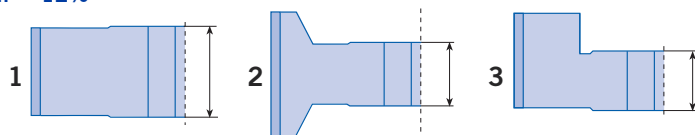



**Frese a rettificare regolabili per bordatrici  
(con anelli distanziali)**

**Adjustable jointing cutterheads for edge banding machines  
(with spacers)**

**Fügefräser für Kantenbearbeitungsmaschinen, verstellbar  
(mit Zwischenringen)**

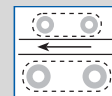

**Fraises extensibles à rectifier pour plaqueuses de chants  
(avec bagues de réglage)**

**Fresas regulables para rectificar con encoladoras de cantos  
(con anillos separadores)**

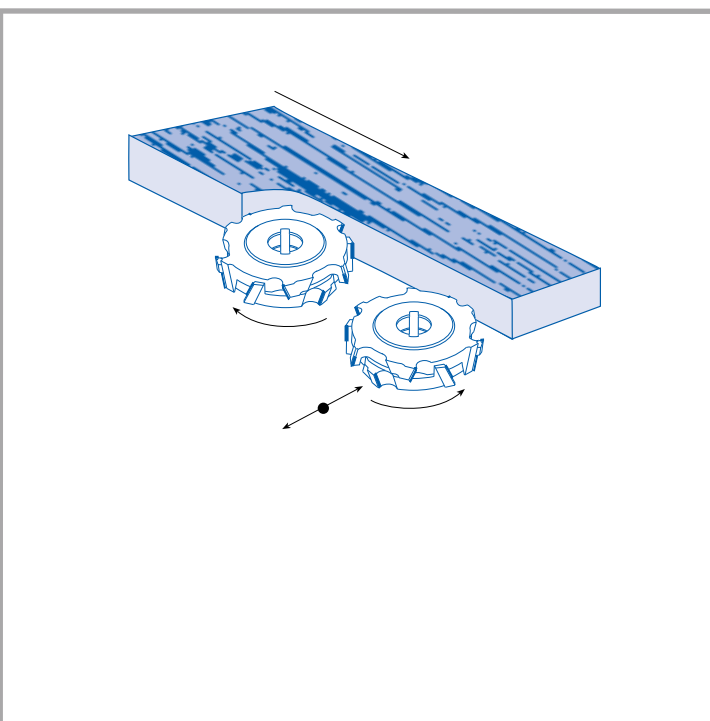
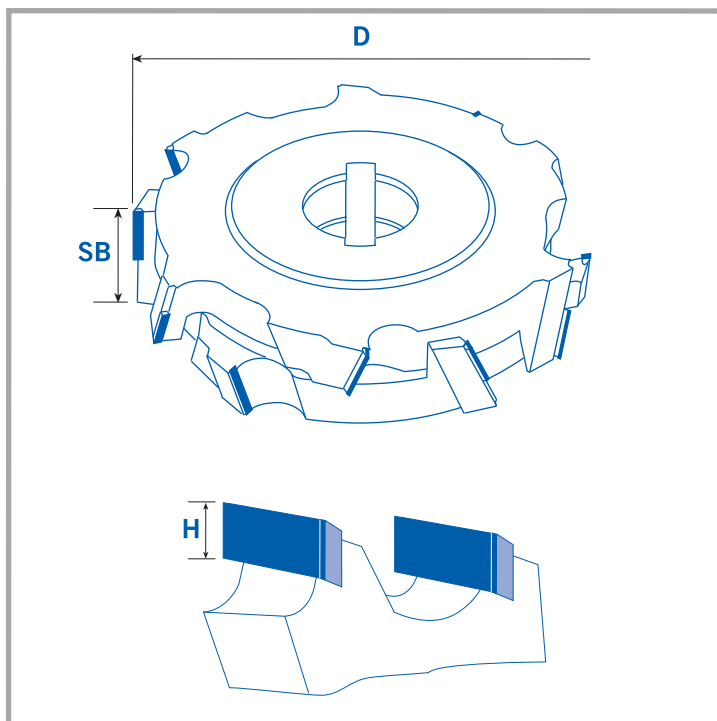

**RTR**



D	SB	Z	H			Prezzo Price Preis Prix Precio	Affilatura Sharpening Erodieren Affûtage Afilado
80 - 125	20 - 30	2 + 2 + 2 + 2	5	10	12.000	€ 690,00	€ 140,00
80 - 125	28 - 38	2 + 2 + 2 + 2	5	10	12.000	€ 770,00	€ 180,00
80 - 125	36 - 52	2 + 2 + 2 + 2	5	10	12.000	€ 915,00	€ 240,00
80 - 125	50 - 67	2 + 2 + 2 + 2 + 2 + 2	5	10	12.000	€ 1.090,00	€ 290,00
80 - 125	20 - 30	3 + 3 + 3 + 3	5	15	12.000	€ 850,00	€ 210,00
80 - 125	28 - 38	3 + 3 + 3 + 3	5	15	12.000	€ 970,00	€ 270,00
80 - 125	36 - 52	3 + 3 + 3 + 3	5	15	12.000	€ 1.185,00	€ 360,00
80 - 125	50 - 67	3 + 3 + 3 + 3 + 3 + 3	5	15	12.000	€ 1.450,00	€ 435,00
100 - 125	20 - 30	4 + 4 + 4 + 4	5	20	12.000	€ 1.010,00	€ 280,00
100 - 125	28 - 38	4 + 4 + 4 + 4	5	20	12.000	€ 1.170,00	€ 360,00
100 - 125	36 - 52	4 + 4 + 4 + 4	5	20	12.000	€ 1.460,00	€ 480,00
100 - 125	50 - 67	4 + 4 + 4 + 4 + 4 + 4	5	20	12.000	€ 1.810,00	€ 580,00

H=Dia 6 mm + 8%  
H=Dia 4 mm - 8%  
H=Dia 3 mm -12%



# Frese a rettificare per bordatrici a 45°

Jointing cutterheads for edge banding machines 45°

Fügefräser für Kantenbearbeitungsmaschinen 45°

Fraises à rectifier pour plaqueuses de chants 45°

Fresas para rectificar con encoladoras de cantos 45°

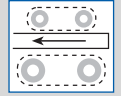

## RTF45°

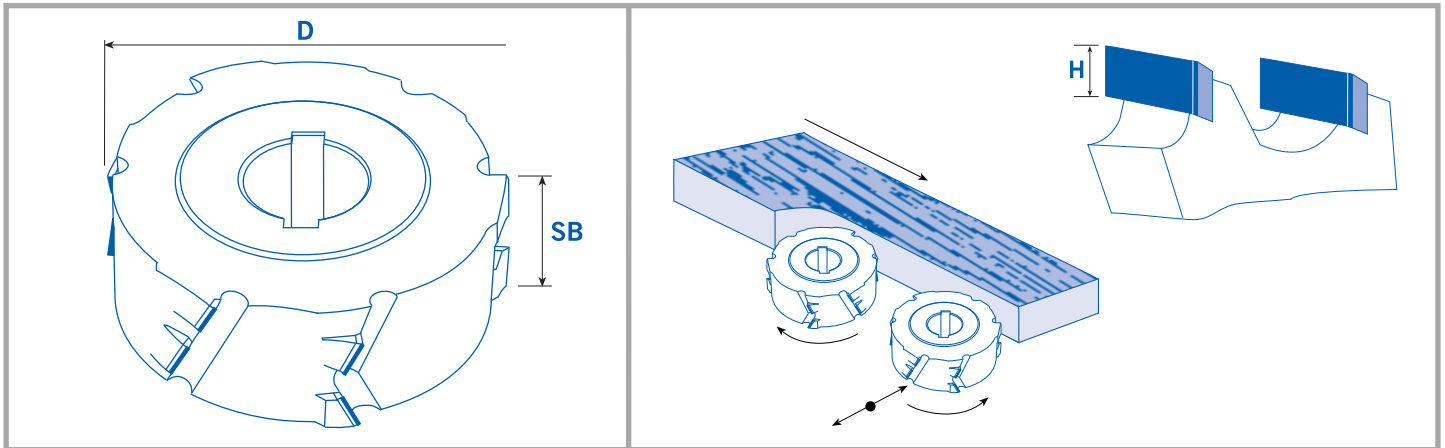

D	SB	Z	H	← m/1'	 n/max	Prezzo Price Preis Prix Precio	Affilatura Sharpening Erodieren Affûtage Afilado
50 - 125	28	2 + 2	5	18 / 25	18.000 / 15.000	€ 550,00	€ 190,00
50 - 125	35	2 + 2	5	18 / 25	18.000 / 15.000	€ 650,00	€ 250,00
50 - 125	43	2 + 2	5	18 / 25	18.000 / 15.000	€ 750,00	€ 315,00
50 - 125	48	2 + 2	5	18 / 25	18.000 / 15.000	€ 800,00	€ 370,00
50 - 125	56	2 + 2	5	18 / 25	18.000 / 15.000	€ 920,00	€ 405,00
50 - 125	63	2 + 2	5	18 / 25	18.000 / 15.000	€ 1.030,00	€ 435,00
50 - 125	28	3 + 3	5	18 / 25	18.000 / 15.000	€ 700,00	€ 285,00
50 - 125	35	3 + 3	5	18 / 25	18.000 / 15.000	€ 860,00	€ 370,00
50 - 125	43	3 + 3	5	18 / 25	18.000 / 15.000	€ 1.030,00	€ 410,00
50 - 125	48	3 + 3	5	18 / 25	18.000 / 15.000	€ 1.100,00	€ 440,00
50 - 125	56	3 + 3	5	18 / 25	18.000 / 15.000	€ 1.280,00	€ 480,00
50 - 125	63	3 + 3	5	18 / 25	18.000 / 15.000	€ 1.450,00	€ 520,00
100 - 125	28	4 + 4	5	25 / 30	15.000	€ 860,00	€ 370,00
100 - 125	35	4 + 4	5	25 / 30	15.000	€ 1.080,00	€ 430,00
100 - 125	43	4 + 4	5	25 / 30	15.000	€ 1.310,00	€ 495,00
100 - 125	48	4 + 4	5	25 / 30	15.000	€ 1.390,00	€ 545,00
100 - 125	56	4 + 4	5	25 / 30	15.000	€ 1.630,00	€ 600,00
100 - 125	63	4 + 4	5	25 / 30	15.000	€ 1.880,00	€ 675,00

H=Dia 6 mm + 8%  
H=Dia 4 mm - 8%  
H=Dia 3 mm - 12%

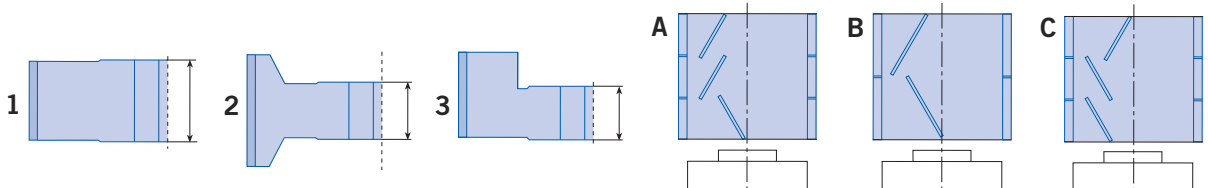



**Frese a rettificare regolabili per bordatrici a 45°  
(con anelli distanziali)**

**Adjustable jointing cutterheads for edge banding machines 45°  
(with spacers)**

**Fügefräser für Kantenbearbeitungsmaschinen, verstellbar 45°  
(mit Zwischenringen)**

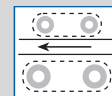

**Fraises extensibles à rectifier pour plaqueuses de chants 45°  
(avec bagues de réglage)**

**Fresas regulables para rectificar con encoladoras de cantos 45°  
(con anillos separadores)**

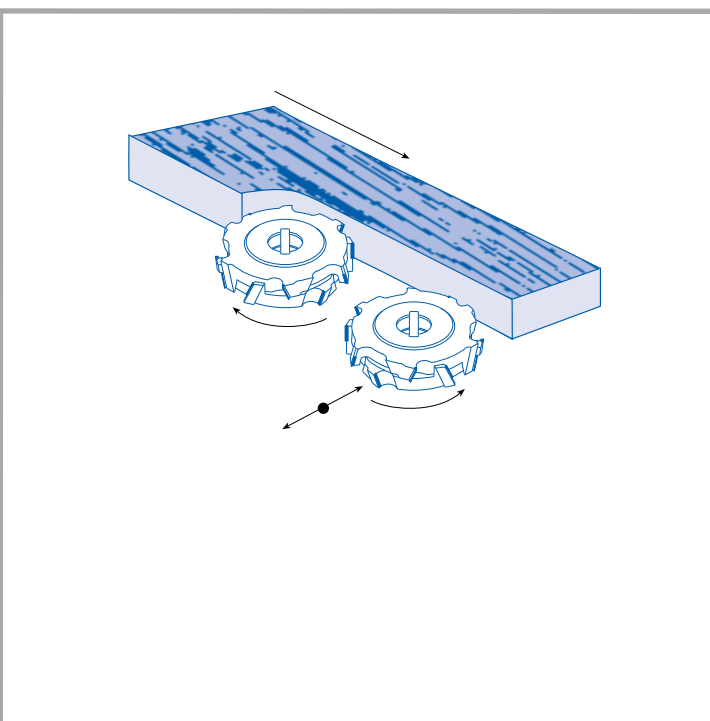
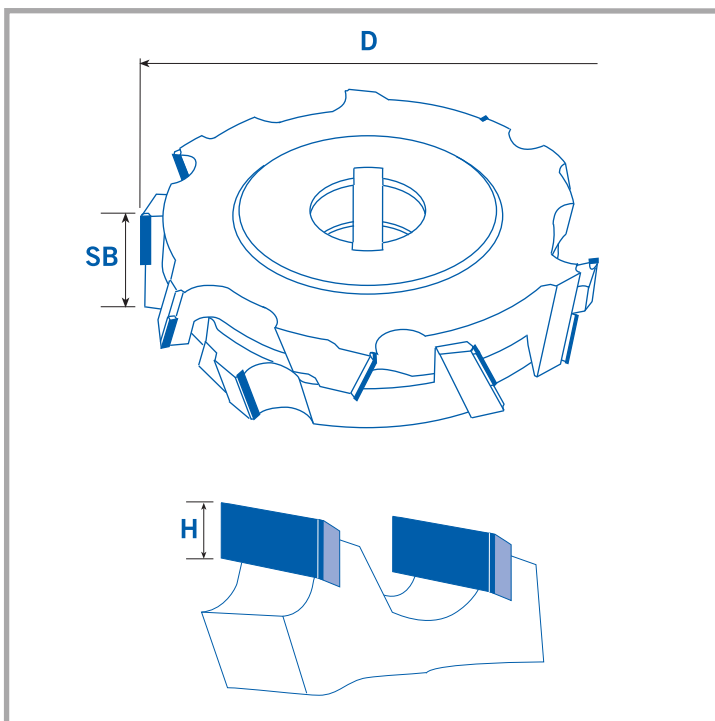

**RTR45°**



D	SB	Z	H			Prezzo Price Preis Prix Precio	Affilatura Sharpening Erodieren Affûtage Afilado
80 - 125	20 - 30	2 + 2 + 2 + 2	5	10	12.000	€ 790,00	€ 190,00
80 - 125	28 - 38	2 + 2 + 2 + 2	5	10	12.000	€ 850,00	€ 210,00
80 - 125	36 - 52	2 + 2 + 2 + 2	5	10	12.000	€ 1.140,00	€ 315,00
80 - 125	50 - 67	2 + 2 + 2 + 2	5	10	12.000	€ 1.190,00	€ 350,00
80 - 125	20 - 30	3 + 3 + 3 + 3	5	15	12.000	€ 1.000,00	€ 275,00
80 - 125	28 - 38	3 + 3 + 3 + 3	5	15	12.000	€ 1.090,00	€ 315,00
80 - 125	36 - 52	3 + 3 + 3 + 3	5	15	12.000	€ 1.520,00	€ 470,00
80 - 125	50 - 67	3 + 3 + 3 + 3	5	15	12.000	€ 1.600,00	€ 525,00
100 - 125	20 - 30	4 + 4 + 4 + 4	5	20	12.000	€ 1.200,00	€ 370,00
100 - 125	28 - 38	4 + 4 + 4 + 4	5	20	12.000	€ 1.330,00	€ 420,00
100 - 125	36 - 52	4 + 4 + 4 + 4	5	20	12.000	€ 1.910,00	€ 630,00
100 - 125	50 - 67	4 + 4 + 4 + 4 + 4 + 4	5	20	12.000	€ 2.000,00	€ 700,00

H=Dia 6 mm + 8%  
H=Dia 4 mm - 8%  
H=Dia 3 mm -12%



## Frese a rettificare per bordatrici a 54°

Jointing cutterheads for edge banding machines 54°

Fügefräser für Kantenbearbeitungsmaschinen 54°

Fraises à rectifier pour plaqueuses de chants 54°

Fresas para rectificar con encoladoras de cantos 54°

**RTF54°**

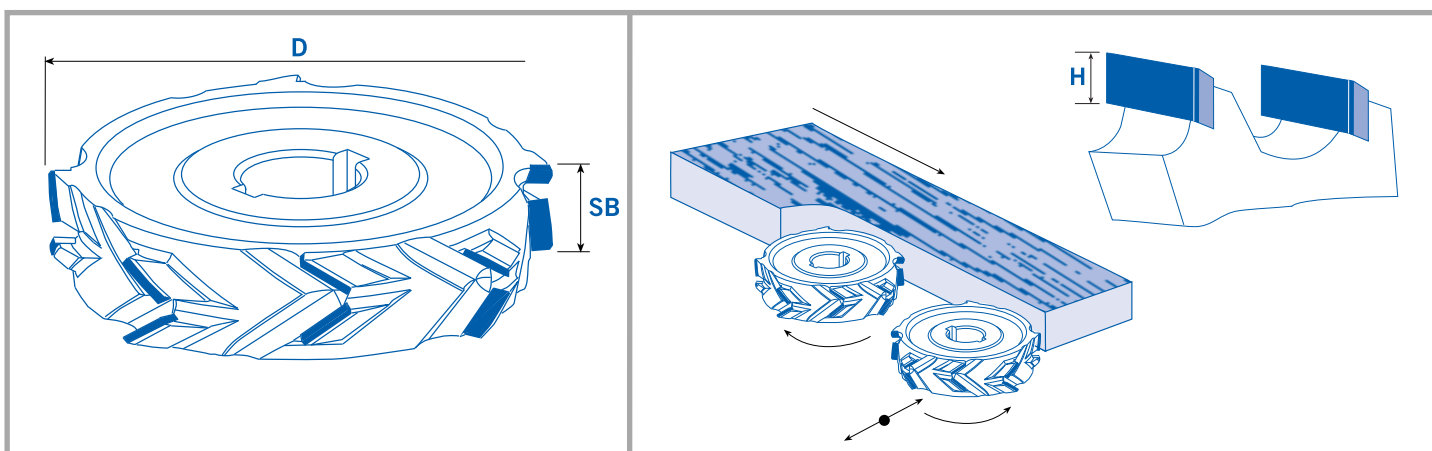
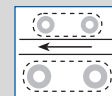

D	SB	Z	H	← m/1'	 n/max	Prezzo Price Preis Prix Precio	Affilatura Sharpening Erodieren Affûtage Afilado
70	28	2 + 2	6	18 / 25	18.000 / 15.000	€ 760,00	€ 210,00
70	35	2 + 2	6	18 / 25	18.000 / 15.000	€ 900,00	€ 240,00
70	43	2 + 2	6	18 / 25	18.000 / 15.000	€ 1.050,00	€ 280,00
70	48	2 + 2	6	18 / 25	18.000 / 15.000	€ 1.280,00	€ 330,00
70	56	2 + 2	6	18 / 25	18.000 / 15.000	€ 1.340,00	€ 380,00
70	63	2 + 2	6	18 / 25	18.000 / 15.000	€ 1.500,00	€ 430,00
70	28	3 + 3	6	18 / 25	18.000 / 15.000	€ 1.050,00	€ 280,00
70	35	3 + 3	6	18 / 25	18.000 / 15.000	€ 1.300,00	€ 350,00
70	43	3 + 3	6	18 / 25	18.000 / 15.000	€ 1.480,00	€ 420,00
70	48	3 + 3	6	18 / 25	18.000 / 15.000	€ 1.700,00	€ 490,00
70	56	3 + 3	6	18 / 25	18.000 / 15.000	€ 1.950,00	€ 565,00
70	63	3 + 3	6	18 / 25	18.000 / 15.000	€ 2.150,00	€ 630,00
100 - 125	28	4 + 4	6	25 / 30	15.000	€ 1.350,00	€ 380,00
100 - 125	35	4 + 4	6	25 / 30	15.000	€ 1.650,00	€ 470,00
100 - 125	43	4 + 4	6	25 / 30	15.000	€ 1.950,00	€ 560,00
100 - 125	48	4 + 4	6	25 / 30	15.000	€ 2.200,00	€ 660,00
100 - 125	56	4 + 4	6	25 / 30	15.000	€ 2.500,00	€ 750,00
100 - 125	63	4 + 4	6	25 / 30	15.000	€ 2.800,00	€ 860,00

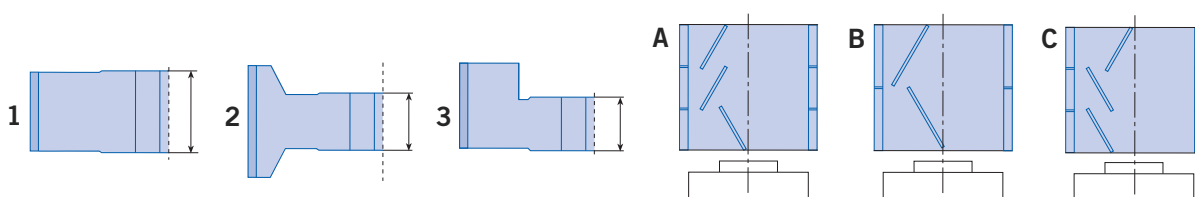



**Frese a rettificare regolabili per bordatrici a 54°  
(con anelli distanziali)**

**Adjustable jointing cutterheads for edge banding machines 54°  
(with spacers)**

**Fügefräser für Kantenbearbeitungsmaschinen, verstellbar 54°  
(mit Zwischenringen)**

**Fraises extensibles à rectifier pour plaqueuses de chants 54°  
(avec bagues de réglage)**

**Fresas regulables para rectificar con encoladoras de cantos 54°  
(con anillos separadores)**

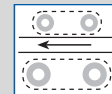

**RTR54°**

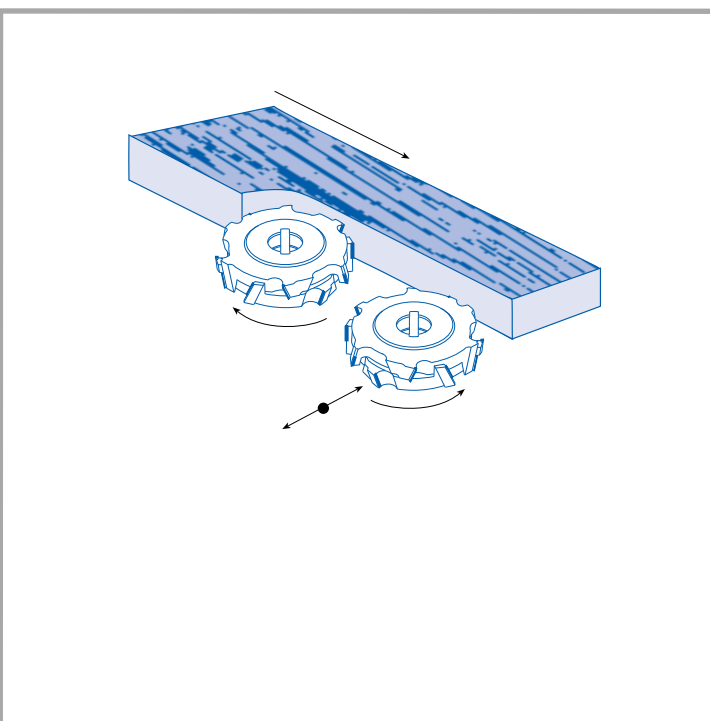
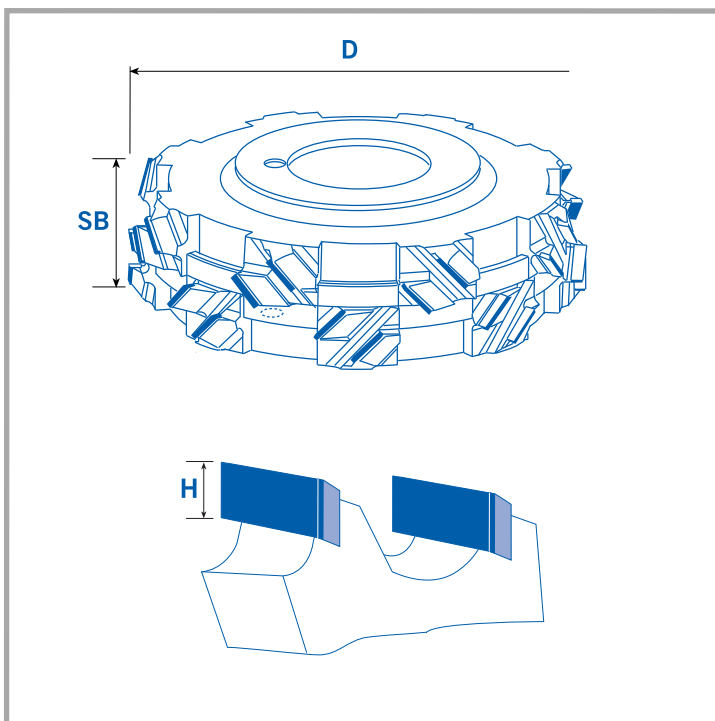

D	SB	Z	H	$\leftarrow \text{m/1'}$	$\ominus \text{ n/max } \oplus$	Prezzo Price Preis Prix Precio	Affilatura Sharpening Erodieren Affûtage Afilado
80 - 125	20 - 30	2 + 2 + 2 + 2	6	10	12.000 / 15.000	€ 950,00	€ 210,00
80 - 125	28 - 38	2 + 2 + 2 + 2	6	10	12.000 / 15.000	€ 1.250,00	€ 315,00
80 - 125	36 - 52	2 + 2 + 2 + 2	6	10	12.000 / 15.000	€ 1.520,00	€ 420,00
80 - 125	50 - 67	2 + 2 + 2 + 2	6	10	12.000 / 15.000	€ 1.850,00	€ 525,00
80 - 125	20 - 30	3 + 3 + 3 + 3	6	15	12.000 / 15.000	€ 1.250,00	€ 315,00
80 - 125	28 - 38	3 + 3 + 3 + 3	6	15	12.000 / 15.000	€ 1.700,00	€ 470,00
80 - 125	36 - 52	3 + 3 + 3 + 3	6	15	12.000 / 15.000	€ 2.100,00	€ 630,00
80 - 125	50 - 67	3 + 3 + 3 + 3	6	15	12.000 / 15.000	€ 2.550,00	€ 790,00
100 - 125	20 - 30	4 + 4 + 4 + 4	6	20	12.000	€ 1.520,00	€ 420,00
100 - 125	28 - 38	4 + 4 + 4 + 4	6	20	12.000	€ 2.100,00	€ 630,00
100 - 125	36 - 52	4 + 4 + 4 + 4	6	20	12.000	€ 2.700,00	€ 845,00
100 - 125	50 - 67	4 + 4 + 4 + 4 + 4 + 4	6	20	12.000	€ 3.300,00	€ 1.050,00

H=Dia 5 mm - 8%  
H=Dia 4 mm -12%





Fresa in lega leggera  
ad inserti intercambiabili 45° versione Eco

Light-alloy jointing cutter  
with 45° replaceable DP tips Eco version



Fräser in Leichtmetall  
mit Wechselplatten 45° Eco-Version

Fraise en alliage léger  
à plaquettes interchangeables angle d'axe 45° version Econome

Antistilla con cucillas  
en DP a 45° versión Eco

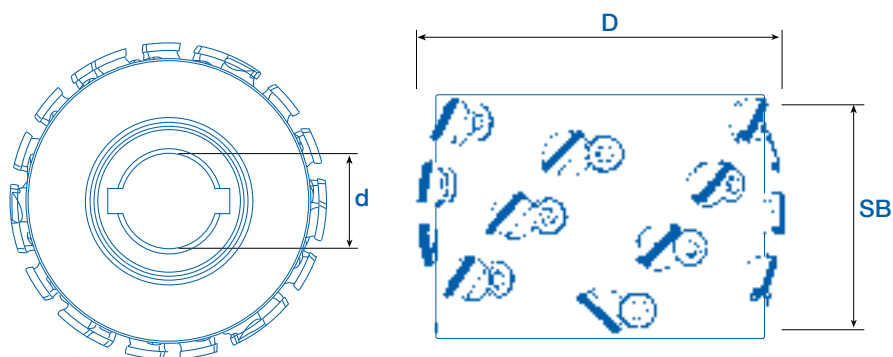
**FCD**



D	SB	d	Z	 m/1'	 n/max	Prezzo Price Preis Prix Precio	Affilatura Sharpening Erodieren Affûtage Afilado
80	38	30	3 + 3 (12)	15 / 20	12.000	€ 821,00	€ 265,00
80	47	30	3 + 3 (15)	15 / 20	12.000	€ 1.026,00	€ 300,00
80	56	30	3 + 3 (18)	15 / 20	12.000	€ 1.231,00	€ 360,00
80	65	30	3 + 3 (21)	15 / 20	12.000	€ 1.436,00	€ 395,00
100	38	30	3 + 3 (12)	15 / 20	12.000	€ 821,00	€ 265,00
100	47	30	3 + 3 (15)	15 / 20	12.000	€ 1.026,00	€ 300,00
100	56	30	3 + 3 (18)	15 / 20	12.000	€ 1.231,00	€ 360,00
100	65	30	3 + 3 (21)	15 / 20	12.000	€ 1.436,00	€ 395,00
125	38	30	3 + 3 (12)	15 / 20	12.000	€ 821,00	€ 265,00
125	47	30	3 + 3 (15)	15 / 20	12.000	€ 1.026,00	€ 300,00
125	56	30	3 + 3 (18)	15 / 20	12.000	€ 1.231,00	€ 360,00
125	65	30	3 + 3 (21)	15 / 20	12.000	€ 1.436,00	€ 395,00



Inserto DP di ricambio  
DP inser part  
DP einlegeteile  
Pièces d'insertion DP  
Partes de inserción DP

€ 70,00



## Frese antischeggia per squadratrici doppie

Anti-chipping cutterheads for double end tenoners

Schutzfräser für Doppelendprofiler

Fraises à rectifier pour façonneuses doubles

Fresas anti-astilla para escuadradoras dobles

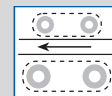

# ANF

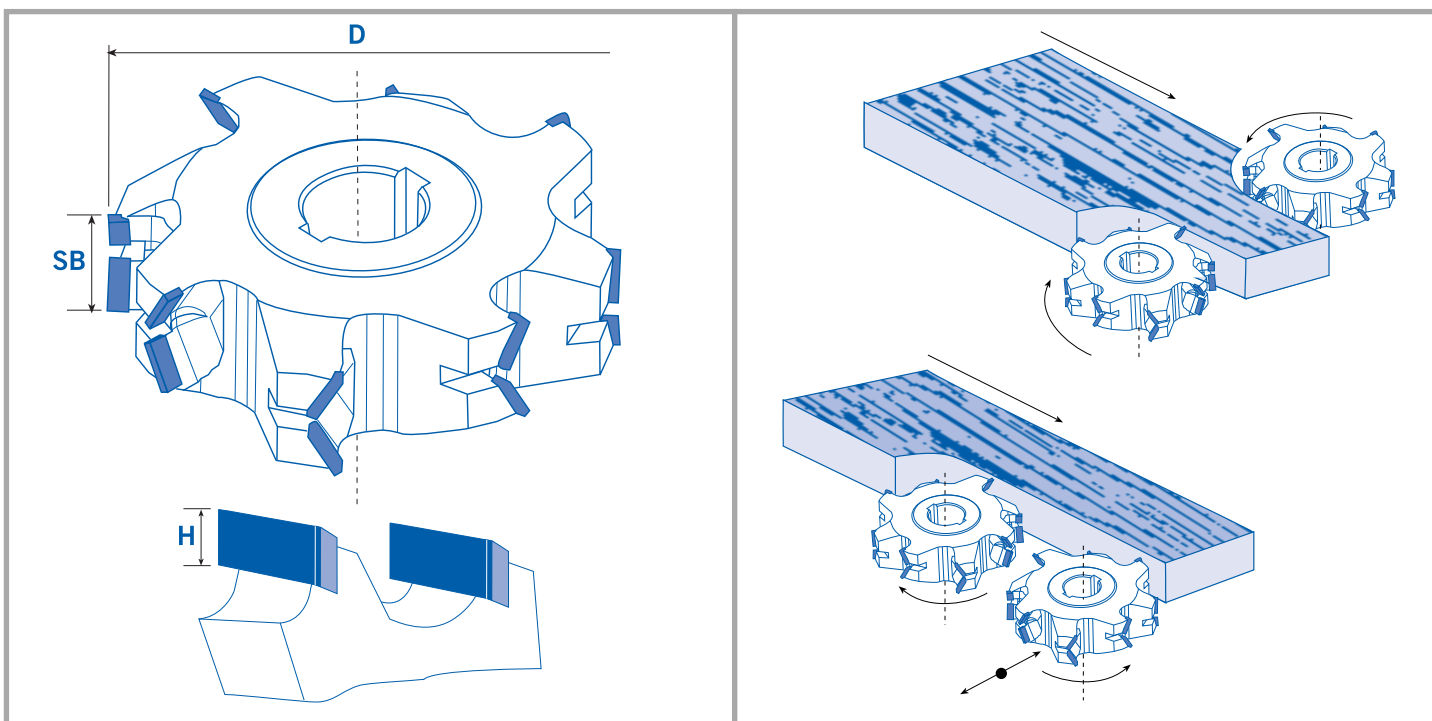

D	SB	Z	H	← m/1'	 n/max	Prezzo Price Preis Prix Precio	Affilatura Sharpening Erodieren Affûtage Afilado
180 - 200	38	4 + 4	5	25	15.000	€ 1.070,00	€ 340,00
180 - 200	45	4 + 4	5	25	15.000	€ 1.200,00	€ 420,00
180 - 200	55	4 + 4	5	25	15.000	€ 1.490,00	€ 500,00
180 - 200	67	4 + 4	5	25	15.000	€ 1.700,00	€ 580,00
180 - 200	85	4 + 4	5	25	15.000	€ 2.100,00	€ 750,00
180 - 200	38	5 + 5	5	30	15.000	€ 1.280,00	€ 420,00
180 - 200	45	5 + 5	5	30	15.000	€ 1.440,00	€ 525,00
180 - 200	55	5 + 5	5	30	15.000	€ 1.800,00	€ 615,00
180 - 200	67	5 + 5	5	30	15.000	€ 2.060,00	€ 650,00
180 - 200	85	5 + 5	5	30	15.000	€ 2.580,00	€ 830,00
180 - 200	38	6 + 6	5	35	15.000	€ 1.485,00	€ 450,00
180 - 200	45	6 + 6	5	35	15.000	€ 1.680,00	€ 630,00
180 - 200	55	6 + 6	5	35	15.000	€ 2.100,00	€ 670,00
180 - 200	67	6 + 6	5	35	15.000	€ 2.420,00	€ 775,00
180 - 200	85	6 + 6	5	35	15.000	€ 3.045,00	€ 990,00

H=Dia 6 mm + 8%  
H=Dia 4 mm - 8%  
H=Dia 3 mm -12%



**Frese antischeggia regolabili per squadratrici doppie  
(con anelli distanziali)**

**Adjustable anti-chipping cutterheads for double end tenoners  
(with spacers)**

**Schutzfräser für Doppelendprofiler, verstellbar  
(mit Zwischenringen)**

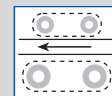

**Fraises extensibles à rectifier pour façonneuses doubles  
(avec bagues de réglage)**

**Fresas anti-astilla regulables para escuadradoras dobles  
(con anillos separadores)**

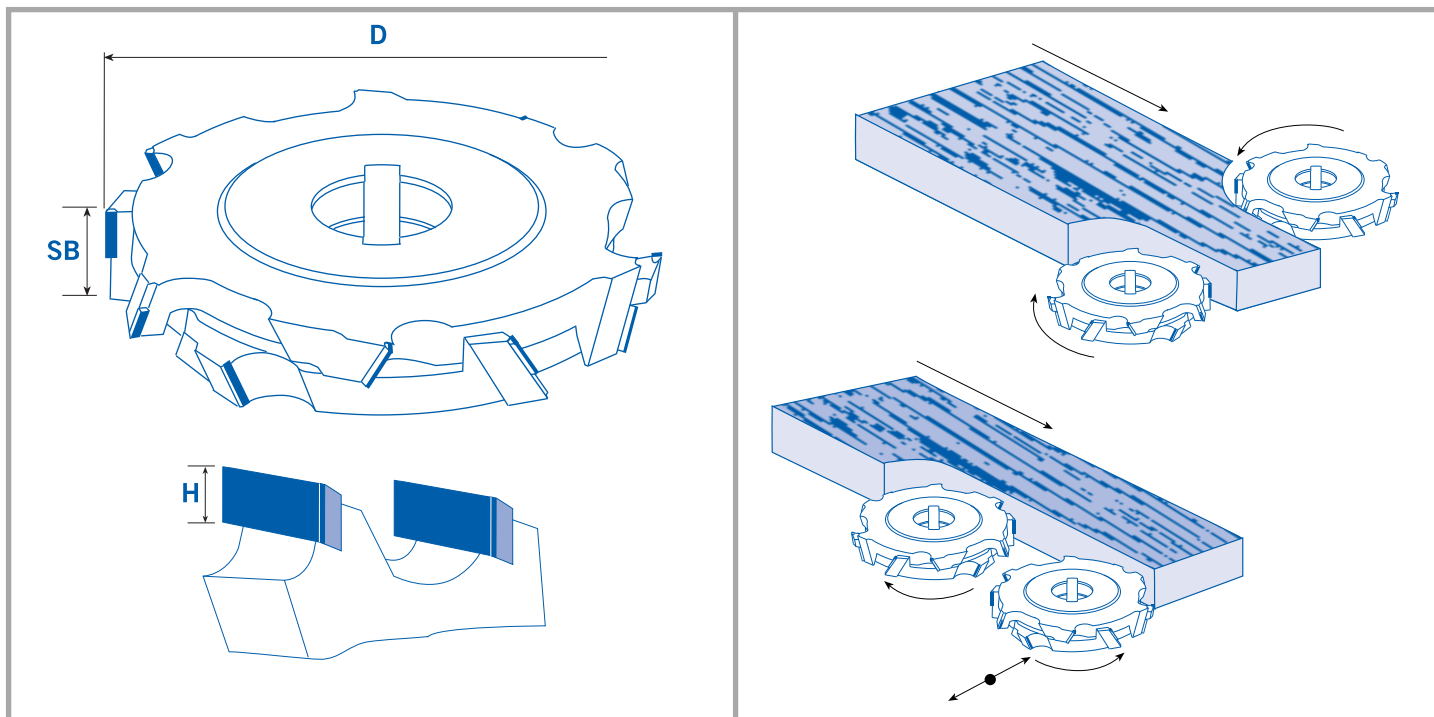

**ANR**



D	SB	Z	H	 m/1'	 n/max	Prezzo Price Preis Prix Precio	Affilatura Sharpening Erodieren Affûtage Afilado
180 - 200	28 - 38	4 + 4 + 4 + 4	5	15	9.000	€ 1.275,00	€ 300,00
180 - 200	28 - 38	5 + 5 + 5 + 5	5	20	9.000	€ 1.475,00	€ 375,00
180 - 200	28 - 38	6 + 6 + 6 + 6	5	25	9.000	€ 1.675,00	€ 450,00
180 - 200	36 - 52	4 + 4 + 4 + 4	5	15	9.000	€ 1.565,00	€ 460,00
180 - 200	36 - 52	5 + 5 + 5 + 5	5	20	9.000	€ 1.835,00	€ 550,00
180 - 200	36 - 52	6 + 6 + 6 + 6	5	25	9.000	€ 2.110,00	€ 670,00
180 - 200	50 - 67	4 + 4 + 4 + 4 + 4 + 4	5	15	9.000	€ 1.915,00	€ 570,00
180 - 200	50 - 67	5 + 5 + 5 + 5 + 5 + 5	5	20	9.000	€ 2.275,00	€ 750,00
180 - 200	50 - 67	6 + 6 + 6 + 6 + 6 + 6	5	25	9.000	€ 2.635,00	€ 860,00

H=Dia 6 mm + 8%  
H=Dia 4 mm - 8%  
H=Dia 3 mm - 12%



Frese antischeggia per squadratrici doppie a 45°

Anti-chipping cutterheads for double end tenoners 45°

Schutzfräser für Doppelendprofiler 45°

Fraises à rectifier pour façonneuses doubles 45°

Fresas anti-astilla para escuadradoras dobles 45°

**ANF45°**

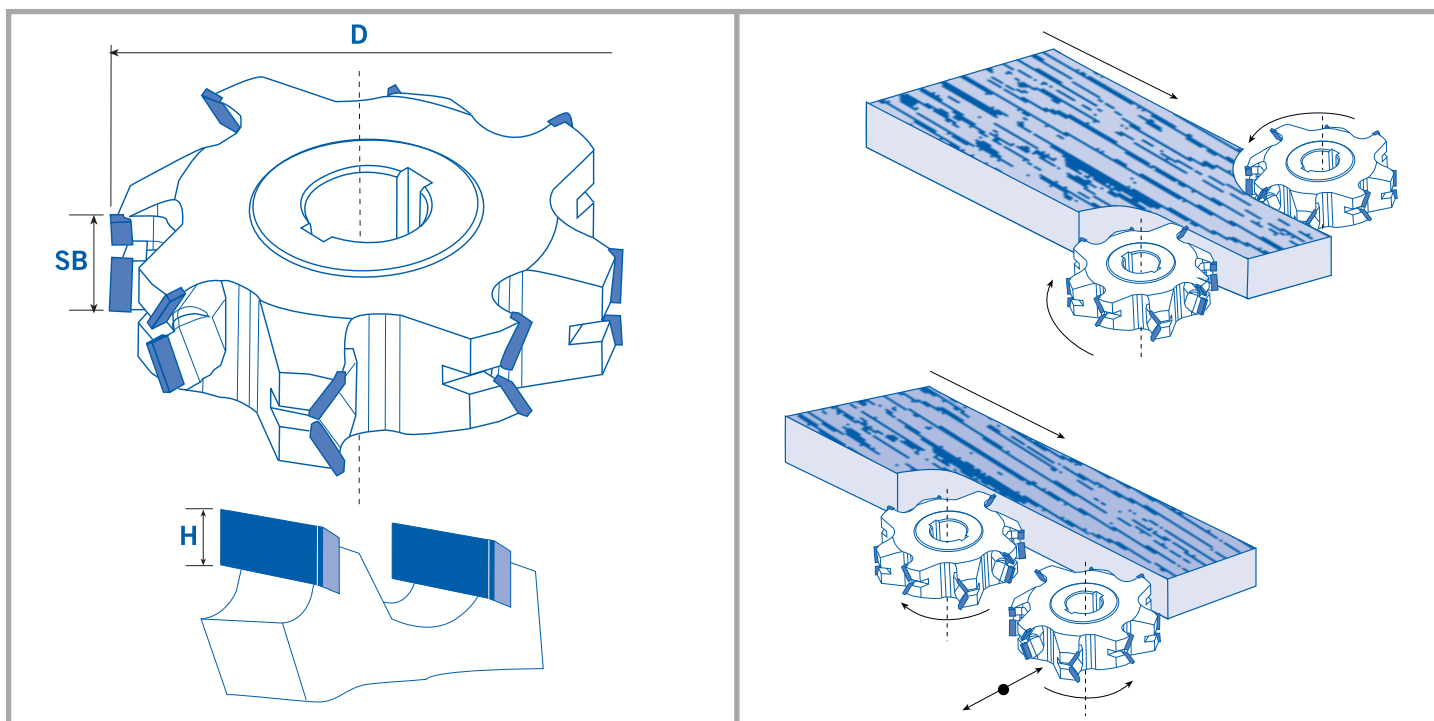
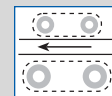

D	SB	Z	H	$\leftarrow m/1'$	$\frac{n}{\text{max}}$	Prezzo Price Preis Prix Precio	Affilatura Sharpening Erodieren Affûtage Afilado
180 - 200	38	4 + 4	5	25	15.000	€ 1.200,00	€ 380,00
180 - 200	45	4 + 4	5	25	15.000	€ 1.450,00	€ 475,00
180 - 200	55	4 + 4	5	25	15.000	€ 1.680,00	€ 570,00
180 - 200	67	4 + 4	5	25	15.000	€ 1.920,00	€ 660,00
180 - 200	85	4 + 4	5	25	15.000	€ 2.540,00	€ 850,00
180 - 200	38	5 + 5	5	30	15.000	€ 1.450,00	€ 475,00
180 - 200	45	5 + 5	5	30	15.000	€ 1.750,00	€ 590,00
180 - 200	55	5 + 5	5	30	15.000	€ 2.040,00	€ 690,00
180 - 200	67	5 + 5	5	30	15.000	€ 2.340,00	€ 830,00
180 - 200	85	5 + 5	5	30	15.000	€ 3.120,00	€ 1.050,00
180 - 200	38	6 + 6	5	35	15.000	€ 1.680,00	€ 570,00
180 - 200	45	6 + 6	5	35	15.000	€ 1.920,00	€ 690,00
180 - 200	55	6 + 6	5	35	15.000	€ 2.400,00	€ 810,00
180 - 200	67	6 + 6	5	35	15.000	€ 2.760,00	€ 990,00
180 - 200	85	6 + 6	5	35	15.000	€ 3.700,00	€ 1.200,00

H=Dia 6 mm + 8%  
H=Dia 4 mm - 8%  
H=Dia 3 mm -12%



**Frese antischeggia regolabili per squadratrici doppie a 45°  
(con anelli distanziali)**

**Adjustable anti-chipping cutterheads for double end tenoners 45°  
(with spacers)**

**Schutzfräser für Doppelendprofile, verstellbar 45°  
(mit Zwischenringen)**

**Fraises extensibles à rectifier pour façonneuses doubles 45°  
(avec bagues de réglage)**

**Fresas anti-astilla regulables para escuadradoras dobles 45°  
(con anillos separadores)**

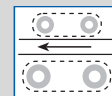

**ANR45°**

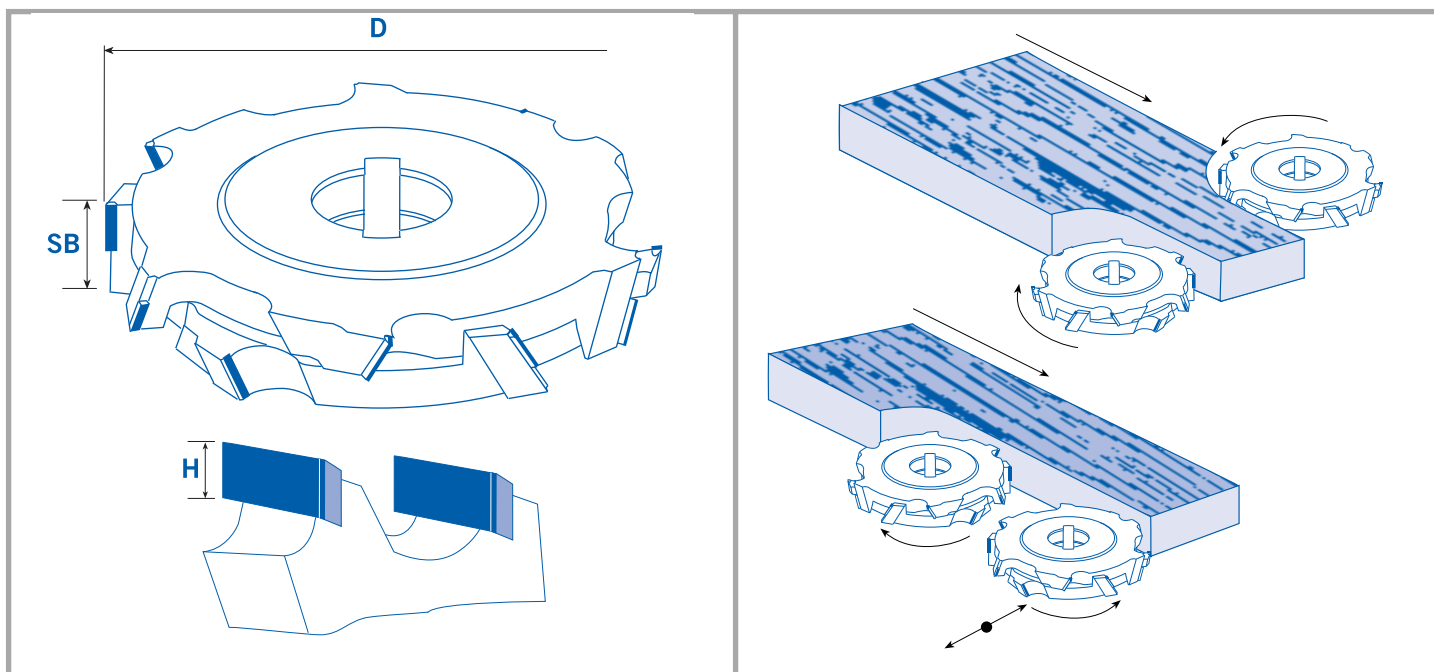

D	SB	Z	H	$\leftarrow m/1'$	$\odot n/\max \ominus$	Prezzo Price Preis Prix Precio	Affilatura Sharpening Erodieren Affûtage Afilado
180 - 200	28 - 38	4 + 4 + 4 + 4	5	15	9.000	€ 1.450,00	€ 350,00
180 - 200	28 - 38	5 + 5 + 5 + 5	5	20	9.000	€ 1.680,00	€ 435,00
180 - 200	28 - 38	6 + 6 + 6 + 6	5	25	9.000	€ 1.920,00	€ 525,00
180 - 200	36 - 52	4 + 4 + 4 + 4	5	15	9.000	€ 2.010,00	€ 560,00
180 - 200	36 - 52	5 + 5 + 5 + 5	5	20	9.000	€ 2.390,00	€ 710,00
180 - 200	36 - 52	6 + 6 + 6 + 6	5	25	9.000	€ 2.780,00	€ 840,00
180 - 200	50 - 67	4 + 4 + 4 + 4 + 4 + 4	5	15	9.000	€ 2.110,00	€ 660,00
180 - 200	50 - 67	5 + 5 + 5 + 5 + 5 + 5	5	20	9.000	€ 2.520,00	€ 830,00
180 - 200	50 - 67	6 + 6 + 6 + 6 + 6 + 6	5	25	9.000	€ 2.930,00	€ 990,00

H=Dia 6 mm + 8%  
H=Dia 4 mm - 8%  
H=Dia 3 mm - 12%



Frese antischeggia per squadratrici doppie a 54°

Anti-chipping cutterheads for double end tenoners 54°

Schutzfräser für Doppelendprofiler 54°

Fraises à rectifier pour façonneuses doubles 54°

Fresas anti-astilla para escuadradoras dobles 54°

**ANF54°**

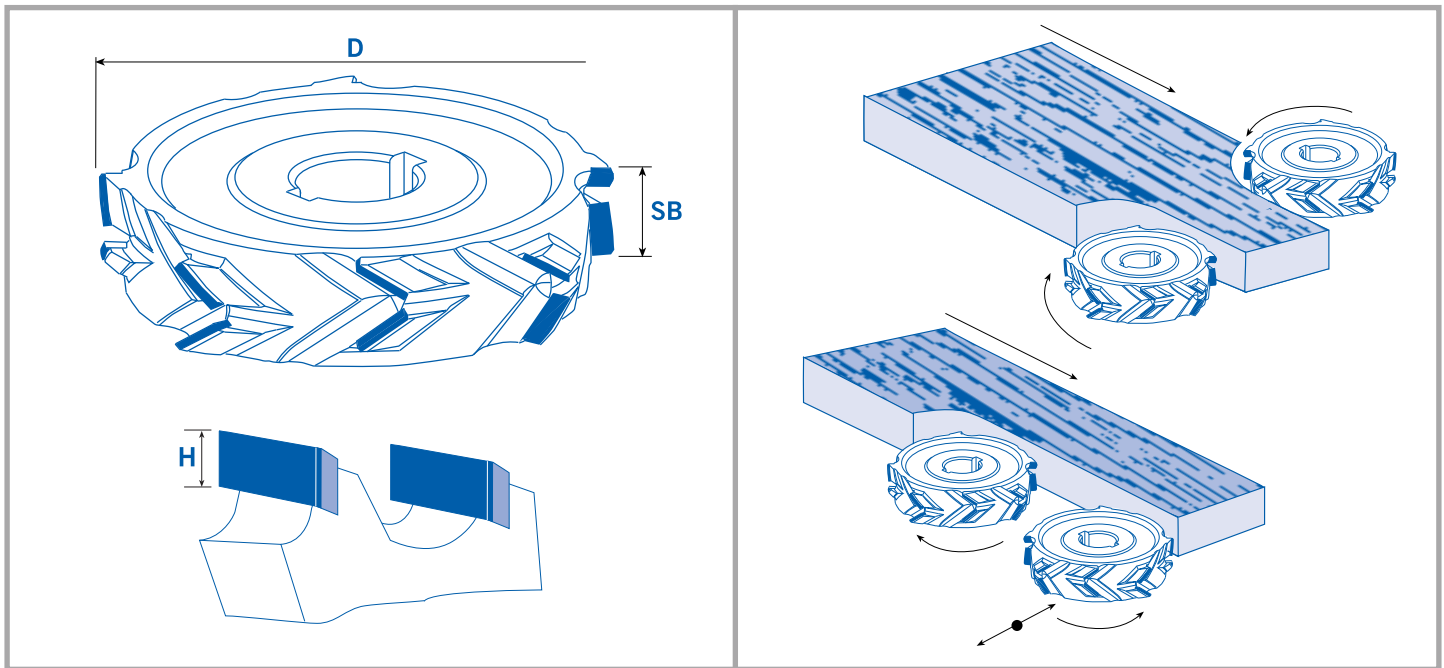
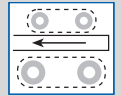

D	SB	Z	H	$\leftarrow \text{m/1'}$	$\ominus \text{ n/max } \oplus$	Prezzo Price Preis Prix Precio	Affilatura Sharpening Erodieren Affûtage Afilado
180 - 200	38	4 + 4	6	15 / 25	15.000	€ 1.700,00	€ 480,00
180 - 200	45	4 + 4	6	15 / 25	15.000	€ 2.300,00	€ 660,00
180 - 200	55	4 + 4	6	15 / 25	15.000	€ 2.600,00	€ 760,00
180 - 200	67	4 + 4	6	15 / 25	15.000	€ 3.000,00	€ 880,00
180 - 200	85	4 + 4	6	15 / 25	15.000	€ 3.700,00	€ 1.150,00
180 - 200	38	5 + 5	6	25 / 35	15.000	€ 2.050,00	€ 600,00
180 - 200	45	5 + 5	6	25 / 35	15.000	€ 2.800,00	€ 840,00
180 - 200	55	5 + 5	6	25 / 35	15.000	€ 3.150,00	€ 955,00
180 - 200	67	5 + 5	6	25 / 35	15.000	€ 3.500,00	€ 1.065,00
180 - 200	85	5 + 5	6	25 / 35	15.000	€ 4.600,00	€ 1.450,00
180 - 200	38	6 + 6	6	35 / 45	15.000	€ 2.400,00	€ 715,00
180 - 200	45	6 + 6	6	35 / 45	15.000	€ 3.300,00	€ 1.000,00
180 - 200	55	6 + 6	6	35 / 45	15.000	€ 3.700,00	€ 1.150,00
180 - 200	67	6 + 6	6	35 / 45	15.000	€ 4.150,00	€ 1.300,00
180 - 200	85	6 + 6	6	35 / 45	15.000	€ 5.450,00	€ 1.700,00

H=Dia 5 mm -8%

H=Dia 4 mm -12%



**Frese antischeggia regolabili per squadratrici doppie a 54°  
(con anelli distanziali)**

**Adjustable anti-chipping cutterheads for double end tenoners 54°  
(with spacers)**

**Schutzfräser für Doppelendprofile, verstellbar 54°  
(mit Zwischenringen)**

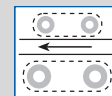

**Fraises extensibles à rectifier pour façonneuses doubles 54°  
(avec bagues de réglage)**

**Fresas anti-astilla regulables para escuadradoras dobles 54°  
(con anillos separadores)**

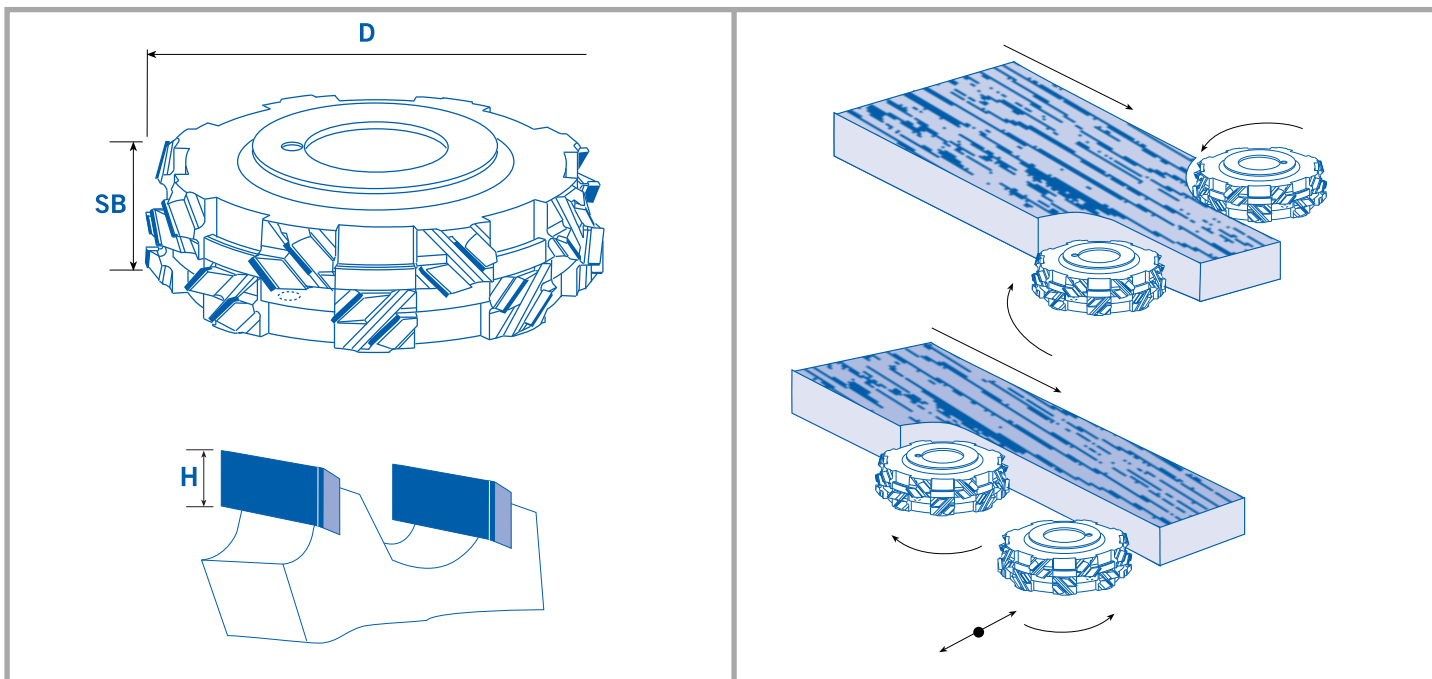

**ANR54°**



D	SB	Z	H	 m/1'	 n/max	Prezzo Price Preis Prix Precio	Affilatura Sharpening Erodieren Affûtage Afilado
180 - 200	28 - 38	4 + 4 + 4 + 4	6	15 / 25	9.000	€ 2.200,00	€ 580,00
180 - 200	28 - 38	5 + 5 + 5 + 5	6	25 / 35	9.000	€ 2.650,00	€ 715,00
180 - 200	28 - 38	6 + 6 + 6 + 6	6	35 / 45	9.000	€ 3.100,00	€ 860,00
180 - 200	36 - 52	4 + 4 + 4 + 4	6	15 / 25	9.000	€ 2.800,00	€ 760,00
180 - 200	36 - 52	5 + 5 + 5 + 5	6	25 / 35	9.000	€ 3.400,00	€ 955,00
180 - 200	36 - 52	6 + 6 + 6 + 6	6	35 / 45	9.000	€ 4.000,00	€ 1.150,00
180 - 200	50 - 67	4 + 4 + 4 + 4 + 4 + 4	6	15 / 25	9.000	€ 3.400,00	€ 955,00
180 - 200	50 - 67	5 + 5 + 5 + 5 + 5 + 5	6	25 / 35	9.000	€ 4.100,00	€ 1.200,00
180 - 200	50 - 67	6 + 6 + 6 + 6 + 6 + 6	6	35 / 45	9.000	€ 4.800,00	€ 1.450,00

H=Dia 5 mm - 8%  
H=Dia 4 mm -12%



# Frese a rifilare diritte

## Edge jointing cutters

### Bündigfräser

#### Fraises pour affleurage

#### Fresas para cantear

**RFD**

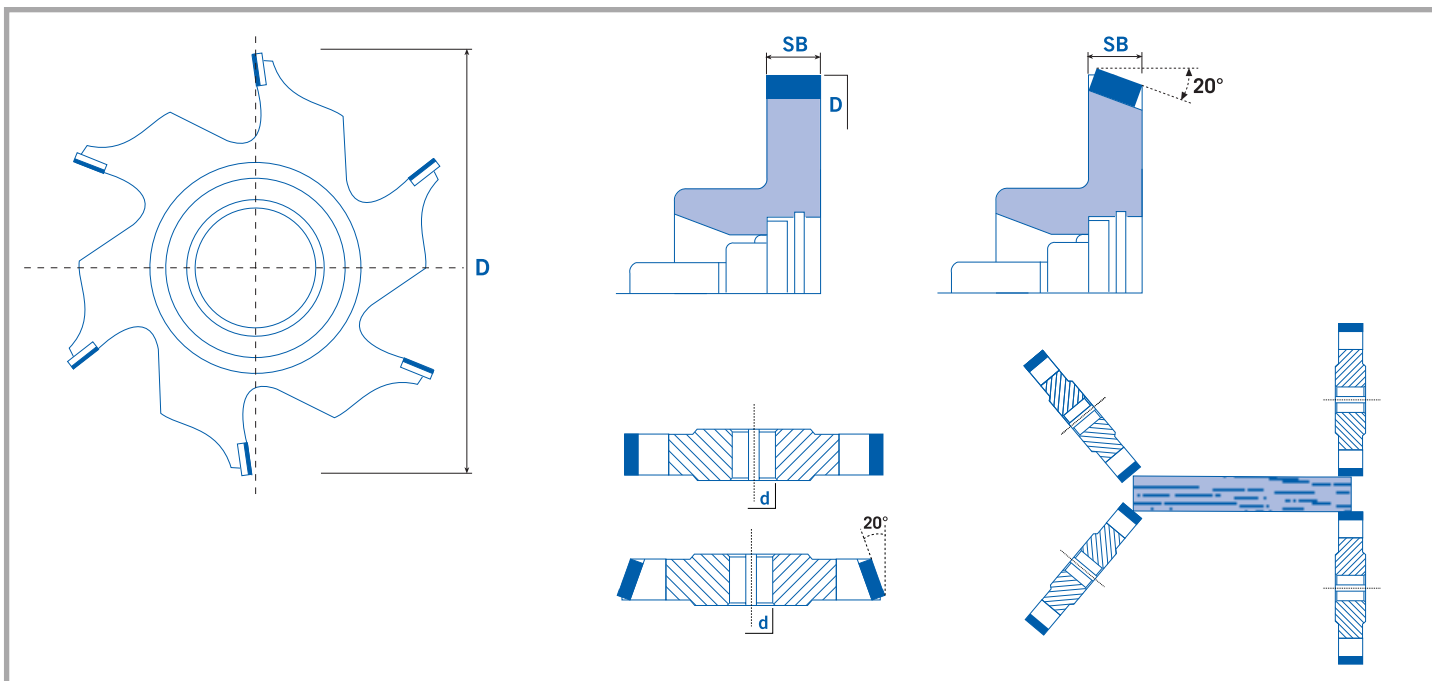
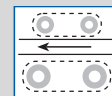

D	SB	Z		d	H			Prezzo Price Preis Prix Precio	Affilatura Sharpening Erodieren Affûtage Afilado
60 - 80	11	4		16 / 20	5	20 / 30	24.000 / 18.000	€ 300,00	€ 100,00
60 - 80	11	4		HSK 25R / HSK 32R	5	20 / 30	24.000 / 18.000	€ 450,00	€ 100,00
60 - 80	11	6		16 / 20	5	30 / 45	24.000 / 18.000	€ 400,00	€ 150,00
60 - 80	11	6		HSK 25R / HSK 32R	5	30 / 45	24.000 / 18.000	€ 580,00	€ 150,00
60 - 80	11	8		16 / 20	5	45 / 60	24.000 / 18.000	€ 485,00	€ 200,00
60 - 80	11	8		HSK 25R / HSK 32R	5	45 / 60	24.000 / 18.000	€ 635,00	€ 200,00
60 - 80	11	4	20	16 / 20	5	30 / 45	24.000 / 18.000	€ 330,00	€ 100,00
60 - 80	11	4	20	HSK 25R / HSK 32R	5	30 / 45	24.000 / 18.000	€ 480,00	€ 100,00
60 - 80	11	6	20	16 / 20	5	30 / 45	24.000 / 18.000	€ 440,00	€ 150,00
60 - 80	11	6	20	HSK 25R / HSK 32R	5	30 / 45	24.000 / 18.000	€ 590,00	€ 150,00
60 - 80	11	8	20	16 / 20	5	45 / 60	24.000 / 18.000	€ 535,00	€ 200,00
60 - 80	11	8	20	HSK 25R / HSK 32R	5	45 / 60	24.000 / 18.000	€ 685,00	€ 200,00

#### ACCESSORI / SPARE PARTS / ZUBEHÖR / ACCESSOIRES / ACCESORIOS

Vite / Screw / Schraube / Vis / Tornillo M 10 x 1,25 x 32

Spessore / Spacer / Abstandring / Bague de réglage / Espesor 18x25x1,0 DIN 988

Seeger / Clamping ring / Seegerring / Bague de sécurité / Anillo de retención 25x1,2 DIN 472

€ 14,00

H=Dia 4 mm - 8%  
H=Dia 3 mm -12%





# Frese a refilare raggate

## Edge rounding cutterheads

### Profilfräser

#### Fraises profilées pour affleurage

#### Fresas de radio para cantear

**RFR**

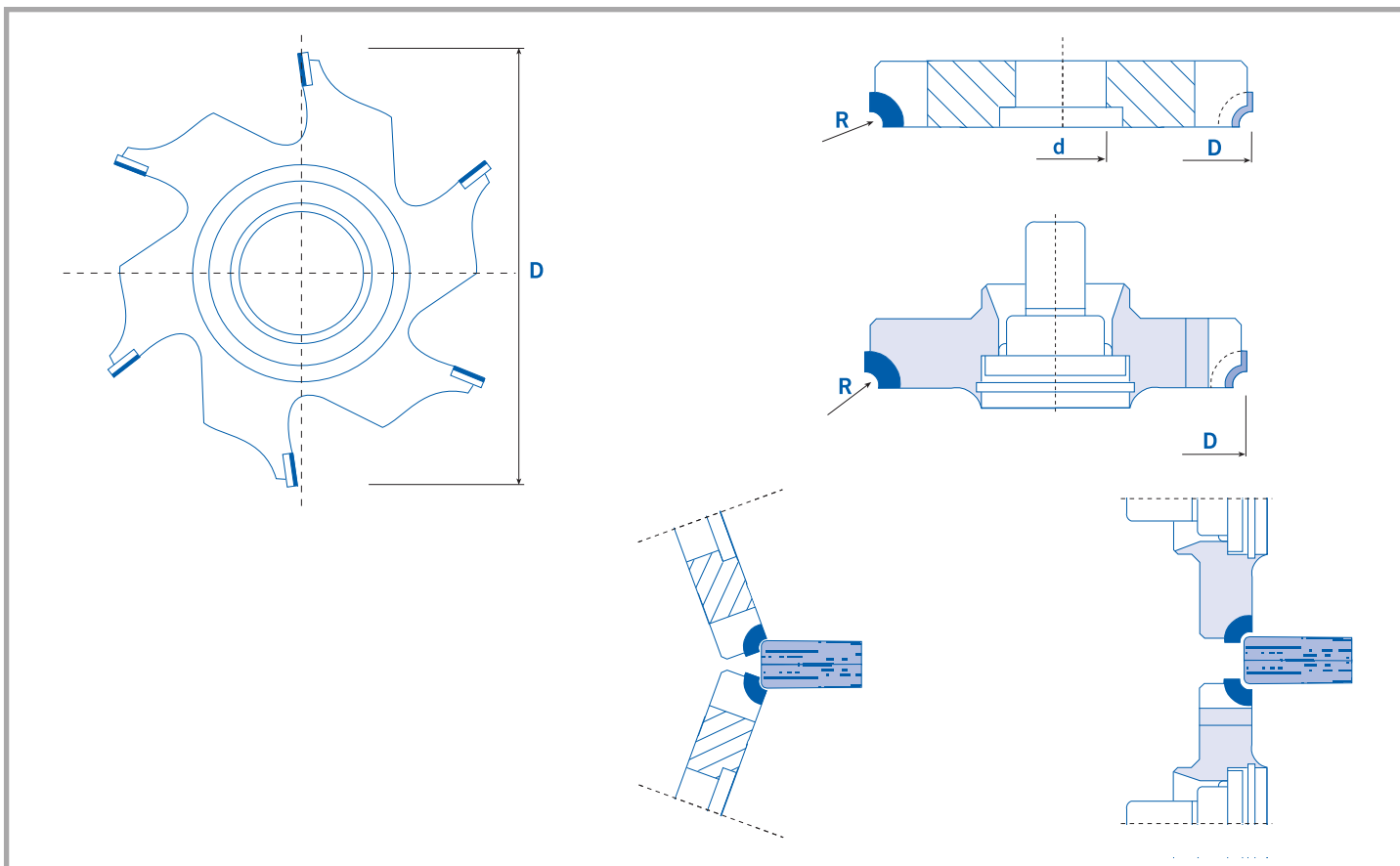
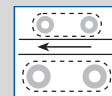

D	R	Z	d	H	$\leftarrow$ m/1'	$\ominus$ n/max $\oplus$	Prezzo Price Preis Prix Precio	Affilatura Sharpening Erodieren Affütage Afilado
60 - 80	1 - 1,5 - 2 - 3	4	16 / 20	3	20 / 30	24.000	€ 400,00	€ 150,00
60 - 80	1 - 1,5 - 2 - 3	4	HSK 25R / HSK 32R	3	20 / 30	24.000 / 18.000	€ 550,00	€ 150,00
60 - 80	1 - 1,5 - 2 - 3	6	16 / 20	3	30 / 45	24.000	€ 500,00	€ 210,00
60 - 80	1 - 1,5 - 2 - 3	6	HSK 25R / HSK 32R	3	30 / 45	24.000 / 18.000	€ 650,00	€ 210,00
80	1 - 1,5 - 2 - 3	8	16 / 20	3	45 / 60	18.000	€ 610,00	€ 280,00
80	1 - 1,5 - 2 - 3	8	HSK 25R / HSK 32R	3	45 / 60	18.000	€ 760,00	€ 280,00
80	1 - 1,5 - 2 - 3	10	16 / 20	3	50 / 70	18.000	€ 690,00	€ 350,00
80	1 - 1,5 - 2 - 3	10	HSK 25R / HSK 32R	3	50 / 70	18.000	€ 840,00	€ 350,00

#### ACCESSORI / SPARE PARTS / ZUBEHÖR / ACCESSOIRES / ACCESORIOS

H=Dia 4 mm +8%

Vite / Screw / Schraube / Vis / Tornillo M 10 x 1,25 x 32

Spessore / Spacer / Abstandring / Bague de réglage / Espesor 18x25x1,0 DIN 988

Seeger / Clamping ring / Seegerring / Bague de sécurité / Anillo de retención 25x1,2 DIN 472

€ 14,00



## Frese a rifilare multiraggio

## Multi-profile edge rounding cutterheads



## Multiprofilfräser

## Fraises pour affleurage multiprofiles

## Fresas multiperfil para cantear

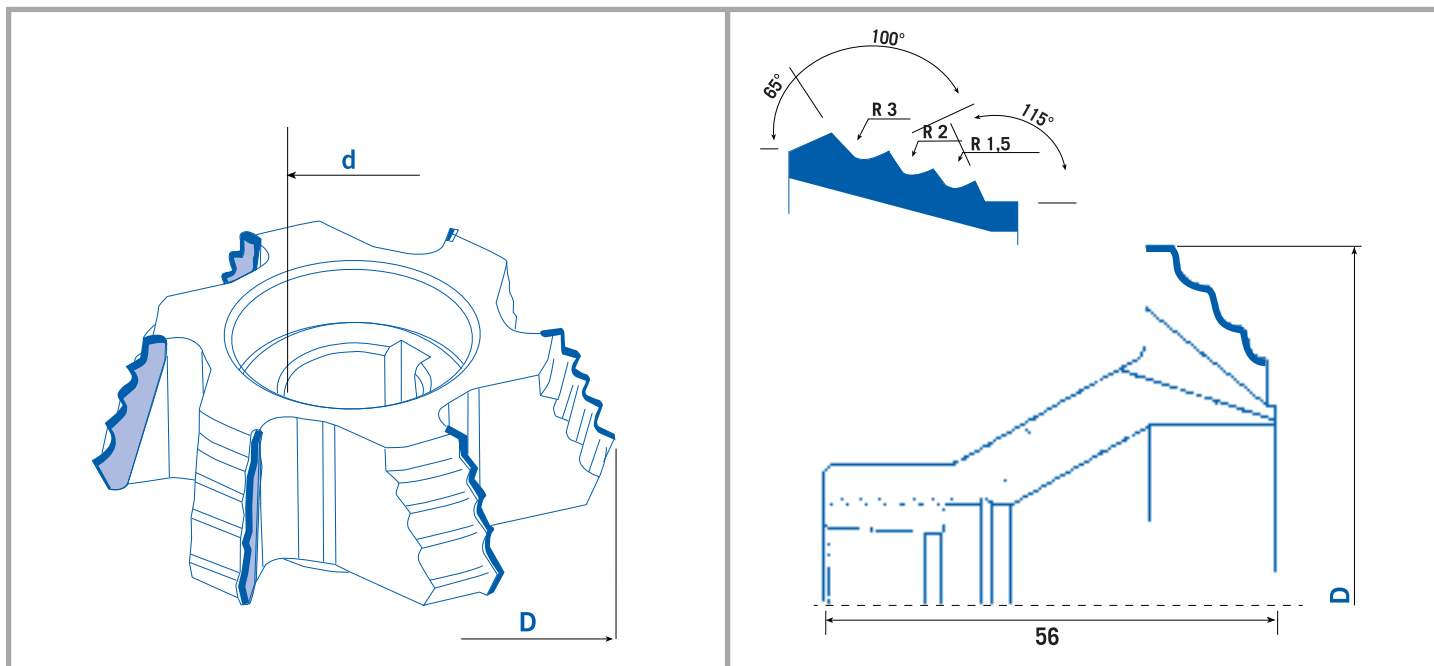
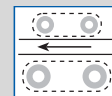
**RFM**



D	R	Z	d	H	 m/1'	 n/max $\Phi$	Prezzo Price Preis Prix Precio	Affilatura Sharpening Erodieren Affûtage Afilado
80 - 85	1,5 - 2 - 3	4	16 / 20	5	20 / 30	24.000	€ 800,00	€ 230,00
80 - 85	1,5 - 2 - 3	4	HSK 25R / HSK 32R	5	20 / 30	24.000 / 18.000	€ 950,00	€ 230,00
80 - 85	1,5 - 2 - 3	6	16 / 20	5	30 / 45	24.000	€ 1.150,00	€ 315,00
80 - 85	1,5 - 2 - 3	6	HSK 25R / HSK 32R	5	30 / 45	24.000 / 18.000	€ 1.300,00	€ 315,00
80 - 85	1,5 - 2 - 3	8	16 / 20	5	45 / 60	24.000	€ 1.400,00	€ 420,00
80 - 85	1,5 - 2 - 3	8	HSK 25R / HSK 32R	5	45 / 60	24.000 / 18.000	€ 1.580,00	€ 420,00
90	1,5 - 2 - 3	4	HSK 25R	5	30	24.000	€ 980,00	€ 230,00
90	1,5 - 2 - 3	6	HSK 25R	5	45	24.000	€ 1.330,00	€ 315,00
90	1,5 - 2 - 3	8	HSK 25R	5	60	24.000	€ 1.580,00	€ 420,00

H=Dia 4 mm -8%

### ACCESSORI / SPARE PARTS / ZUBEHÖR / ACCESSOIRES / ACCESORIOS

Vite / Screw / Schraube / Vis / Tornillo M 10 x 1,25 x 32

Spessore / Spacer / Abstandring / Bague de réglage / Espesor 18x25x1,0 DIN 988

Seeger / Clamping ring / Seegerring / Bague de sécurité / Anillo de retención 25x1,2 DIN 472

€ 14,00



# Informazioni tecniche

## Technical information

### Technische Informationen

### Informations techniques

### Informaciones técnicas

MANCINI UTENSILI

#### Valori indicativi per l'avanzamento del dente "Fz" per articoli LCN - FCF - FCR - FCRS

Indicative values for feeding for teeth "Fz" for art. LCN - FCF - FCR - FCRS

Werte für vorschub pro zahn "Fz" für el. LCN - FCF - FCR - FCRS

Valeurs indicatives pour l'avance par dent "Fz" pour art. LCN - FCF - FCR - FCRS

Valores indicativos por los avance de diente "Fz" para art. LCN - FCF - FCR - FCRS

Legni composti parte centrale Wood composit central part Holzverbund zentralen teil Partie centrale de composite de bois Compuesto de madera parte central	0,30 - 0,60
Legni composti parte superiore Wood composit top part Holzverbund top teil Partie haut de composite de bois Compuesto de madera parte top	0,08 - 0,12
Polimero Polymere board Polymere Polymères Polimeros	0,20 - 0,50
Materie plastiche Plastics Kunststoffe Plastiques Plástica	0,04 - 0,05
Multistrati Plywood Sperrholz Contreplaqué Madera contrachapada	0,40 - 0,50

Truciolari e stratificati Chipboard and laminated Span-und schicht Aggloméré et stratifié Agglomerado y estratificado	
Grezzo Raw Roh Bruts Crudo	0,50 - 0,70
Impiall. Venereed Furniert Plaqués Chapeada	0,10 - 0,15
Rivestiti Coated Beschichteten platten Panneaux revêtus Revestidos	0,20 - 0,40



# Lame per scanalature

## Grooving saw blades

### Nutsägeblätter

### Lames à rainier

### Sierras para ranurar

**LCN**

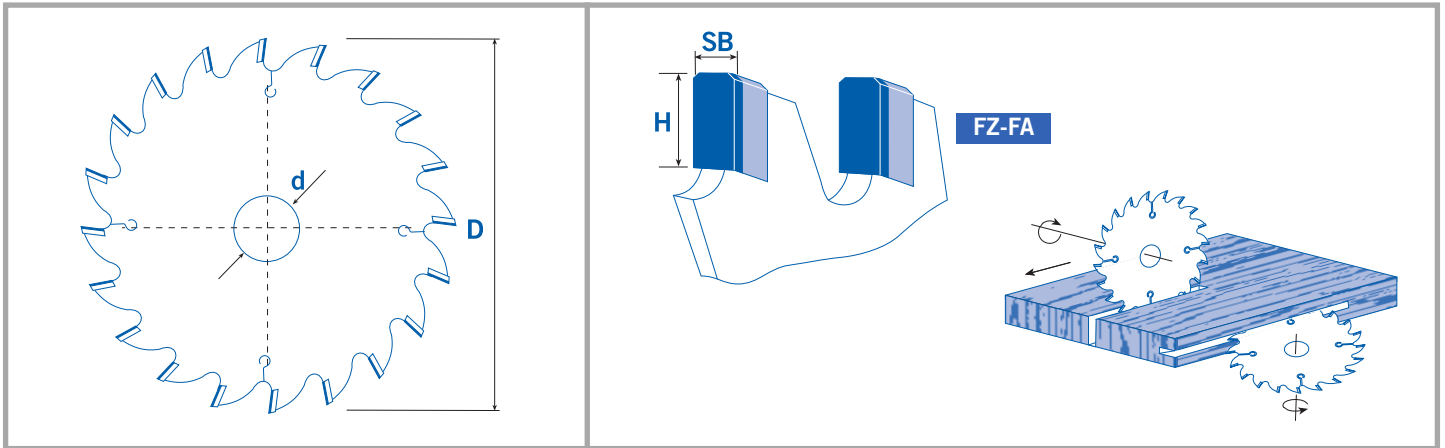
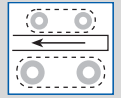

D	SB	Z	H	$\leftarrow \text{m/1'}$	$\odot \text{ n/max } \ominus$	Prezzo Price Preis Prix Precio	Affilatura Sharpening Erodieren Affûtage Afilado
120 - 200	3	12	6	10 / 15	14.200 / 8.500	€ 313,00	€ 150,00
120 - 200	4	12	6	10 / 15	14.200 / 8.500	€ 417,00	€ 180,00
120 - 200	5	12	6	10 / 15	14.200 / 8.500	€ 521,00	€ 220,00
120 - 200	6	12	6	10 / 15	14.200 / 8.500	€ 625,00	€ 250,00
120 - 200	3	16	6	15 / 20	14.200 / 8.500	€ 379,00	€ 170,00
120 - 200	4	16	6	15 / 20	14.200 / 8.500	€ 505,00	€ 200,00
120 - 200	5	16	6	15 / 20	14.200 / 8.500	€ 632,00	€ 240,00
120 - 200	6	16	6	15 / 20	14.200 / 8.500	€ 758,00	€ 280,00
120 - 200	3	20	6	15 / 20	14.200 / 8.500	€ 426,00	€ 200,00
120 - 200	4	20	6	15 / 20	14.200 / 8.500	€ 568,00	€ 230,00
120 - 200	5	20	6	15 / 20	14.200 / 8.500	€ 711,00	€ 270,00
120 - 200	6	20	6	15 / 20	14.200 / 8.500	€ 853,00	€ 305,00
120 - 200	3	24	6	20 / 25	14.200 / 8.500	€ 455,00	€ 230,00
120 - 200	4	24	6	20 / 25	14.200 / 8.500	€ 606,00	€ 260,00
120 - 200	5	24	6	20 / 25	14.200 / 8.500	€ 758,00	€ 300,00
120 - 200	6	24	6	20 / 25	14.200 / 8.500	€ 909,00	€ 340,00
120 - 200	3	30	6	25 / 30	14.200 / 8.500	€ 568,00	€ 270,00
120 - 200	4	30	6	25 / 30	14.200 / 8.500	€ 758,00	€ 310,00
120 - 200	5	30	6	25 / 30	14.200 / 8.500	€ 947,00	€ 350,00
120 - 200	6	30	6	25 / 30	14.200 / 8.500	€ 1.137,00	€ 390,00
120 - 200	3	36	6	30 / 40	14.200 / 8.500	€ 682,00	€ 310,00
120 - 200	4	36	6	30 / 40	14.200 / 8.500	€ 909,00	€ 350,00
120 - 200	5	36	6	30 / 40	14.200 / 8.500	€ 1.137,00	€ 390,00
120 - 200	6	36	6	30 / 40	14.200 / 8.500	€ 1.364,00	€ 440,00

Si possono costruire con mozzo a tazza.

You can build a hub with cup.

Sie können einen hub mit tasse bauen.

Vous pouvez construire un hub avec la cuvette.

Usted puede construir un centro con la taza.

+ € 370,00

H=Dia 5 mm - 8%  
H=Dia 4 mm -12%



## Frese per scanalature

Grooving cutters

Nutfräser

Fraises à rainer

Fresas para ranurar

**FCF**

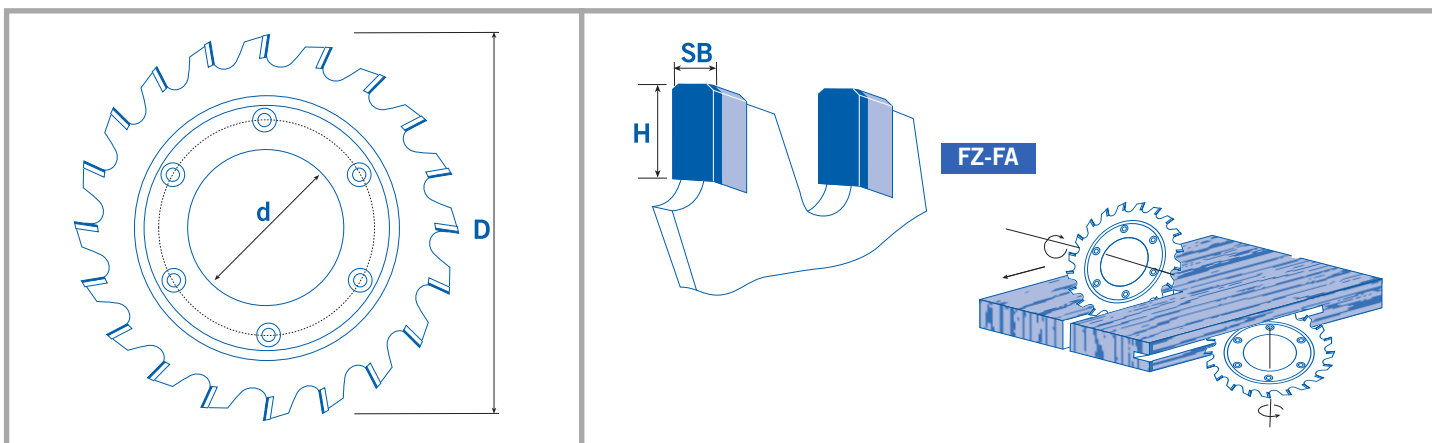
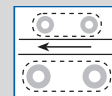

D	SB	Z	H	← m/1'	 n/max	Prezzo Price Preis Prix Precio	Affilatura Sharpening Erodieren Affûtage Afilado
120 - 160	3	12	5	7 / 10	5.000 / 9.000	€ 340,00	€ 150,00
120 - 160	4	12	5	7 / 10	5.000 / 9.000	€ 400,00	€ 180,00
120 - 160	5	12	5	7 / 10	5.000 / 9.000	€ 460,00	€ 220,00
120 - 160	6	12	5	7 / 10	5.000 / 9.000	€ 520,00	€ 250,00
120 - 160	3	16	5	7 / 15	5.000 / 9.000	€ 460,00	€ 170,00
120 - 160	4	16	5	7 / 15	5.000 / 9.000	€ 520,00	€ 200,00
120 - 160	5	16	5	7 / 15	5.000 / 9.000	€ 580,00	€ 240,00
120 - 160	6	16	5	7 / 15	5.000 / 9.000	€ 640,00	€ 280,00
120 - 160	3	20	5	10 / 15	5.000 / 9.000	€ 560,00	€ 200,00
120 - 160	4	20	5	10 / 15	5.000 / 9.000	€ 620,00	€ 230,00
120 - 160	5	20	5	10 / 15	5.000 / 9.000	€ 680,00	€ 270,00
120 - 160	6	20	5	10 / 15	5.000 / 9.000	€ 740,00	€ 310,00
120 - 160	3	24	5	15 / 20	5.000 / 9.000	€ 680,00	€ 230,00
120 - 160	4	24	5	15 / 20	5.000 / 9.000	€ 740,00	€ 260,00
120 - 160	5	24	5	15 / 20	5.000 / 9.000	€ 800,00	€ 300,00
120 - 160	6	24	5	15 / 20	5.000 / 9.000	€ 860,00	€ 340,00

H=Dia 6 mm + 8%  
H=Dia 4 mm - 8%

Si possono costruire con mozzo a tazza.  
You can build a hub with cup.  
Sie können einen hub mit tasse bauen.  
Vous pouvez construire un hub avec la cuvette.  
Usted puede construir un centro con la taza.

+ € 370,00



## Frese per scanalature

Grooving cutters

Nutfräser

Fraises à rainier

Fresas para ranurar

**FCF**

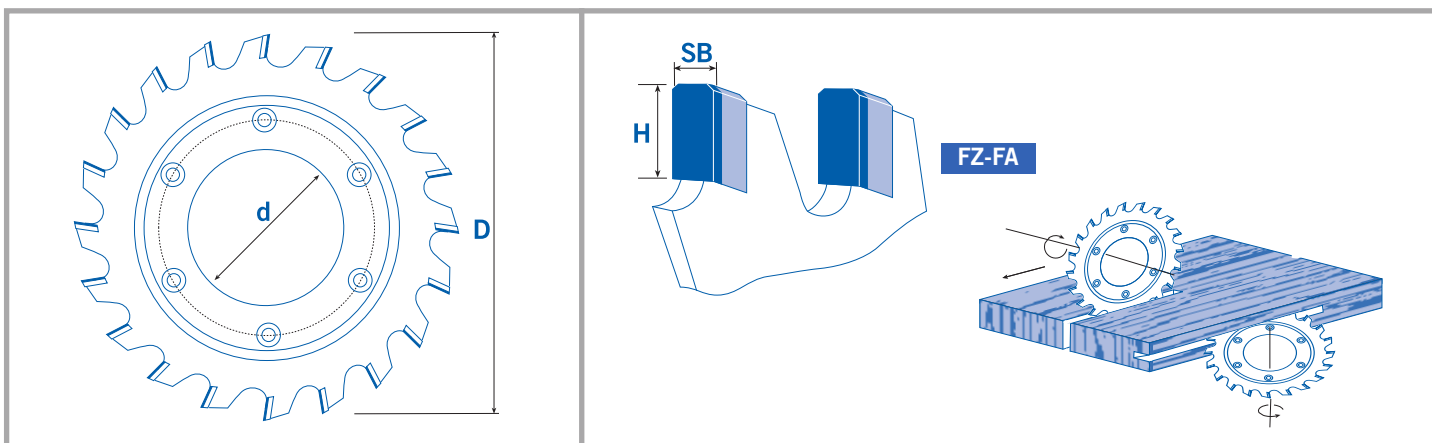
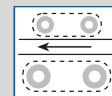

D	SB	Z	H	← m/1'	 n/max	Prezzo Price Preis Prix Precio	Affilatura Sharpening Erodieren Affûtage Afilado
120 - 160	7	12	5	7 / 10	5.000 / 9.000	€ 580,00	€ 290,00
120 - 160	8	12	5	7 / 10	5.000 / 9.000	€ 650,00	€ 330,00
120 - 160	9	12	5	7 / 10	5.000 / 9.000	€ 700,00	€ 370,00
120 - 160	10	8 + 8	5	7 / 10	5.000 / 9.000	€ 650,00	€ 260,00
120 - 160	11	8 + 8	5	7 / 10	5.000 / 9.000	€ 700,00	€ 280,00
120 - 160	12	8 + 8	5	7 / 10	5.000 / 9.000	€ 750,00	€ 300,00
120 - 160	7	16	5	7 / 15	5.000 / 9.000	€ 700,00	€ 320,00
120 - 160	8	16	5	7 / 15	5.000 / 9.000	€ 780,00	€ 370,00
120 - 160	9	16	5	7 / 15	5.000 / 9.000	€ 850,00	€ 400,00
120 - 160	10	10 + 10	5	7 / 15	5.000 / 9.000	€ 740,00	€ 270,00
120 - 160	11	10 + 10	5	7 / 15	5.000 / 9.000	€ 800,00	€ 290,00
120 - 160	12	10 + 10	5	7 / 15	5.000 / 9.000	€ 850,00	€ 305,00
120 - 160	7	20	5	10 / 15	5.000 / 9.000	€ 800,00	€ 350,00
120 - 160	8	20	5	10 / 15	5.000 / 9.000	€ 900,00	€ 400,00
120 - 160	9	20	5	10 / 15	5.000 / 9.000	€ 980,00	€ 440,00
120 - 160	10	12 + 12	5	10 / 15	5.000 / 9.000	€ 850,00	€ 250,00
120 - 160	11	12 + 12	5	10 / 15	5.000 / 9.000	€ 930,00	€ 270,00
120 - 160	12	12 + 12	5	10 / 15	5.000 / 9.000	€ 980,00	€ 285,00
120 - 160	7	24	5	15 / 20	5.000 / 9.000	€ 920,00	€ 330,00
120 - 160	8	24	5	15 / 20	5.000 / 9.000	€ 1.010,00	€ 380,00
120 - 160	9	24	5	15 / 20	5.000 / 9.000	€ 1.120,00	€ 420,00
120 - 160	10	15 + 15	5	15 / 20	5.000 / 9.000	€ 980,00	€ 280,00
120 - 160	11	15 + 15	5	15 / 20	5.000 / 9.000	€ 1.100,00	€ 300,00
120 - 160	12	15 + 15	5	15 / 20	5.000 / 9.000	€ 1.180,00	€ 315,00

H=Dia 6 mm + 8%  
H=Dia 4 mm - 8%



Lama per scanalature regolabile (con anelli distanziali)

Adjustable saw blade (with spacers)

Kreissägeblätter verstellbar (mit zwischenringen)

Lame à rainure extensibles (avec bagues de réglage)

Sierra para ranurar regulables (con anillos separadores)

LCR

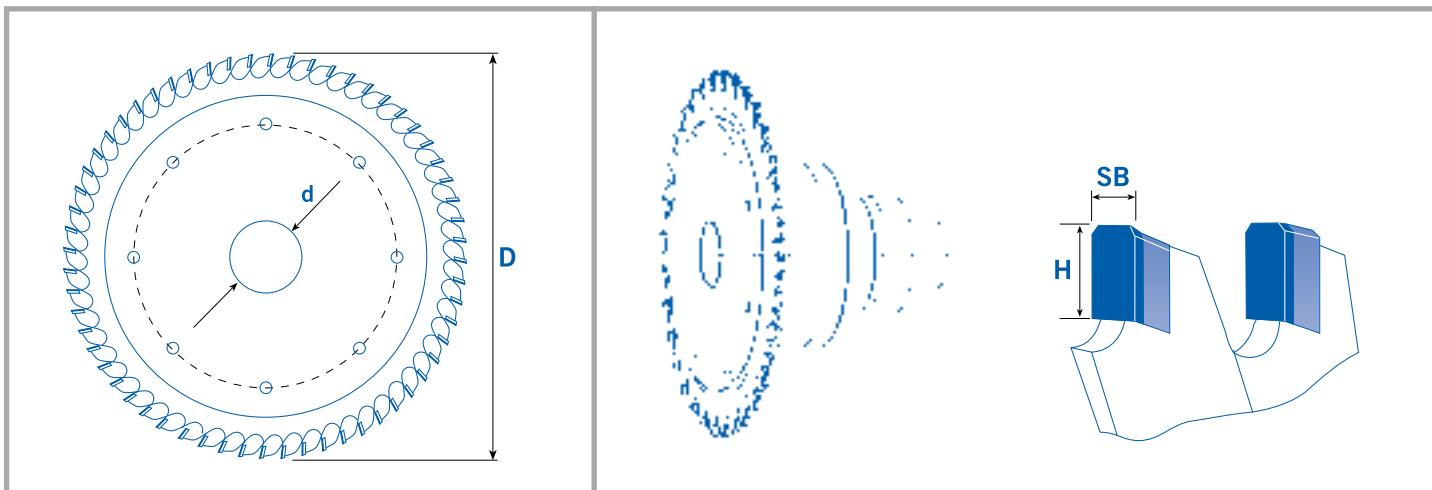

D	SB	Z	H	$\leftarrow \text{m/1'} \rightarrow$	$\odot \text{ n/max } \odot$	Prezzo Price Preis Prix Precio	Affilatura Sharpening Erodieren Affûtage Afilado
200	4, 1/5	16 + 16	6	35	10.000	€ 1.350,00	€ 185,00
200	4, 1/5	30 + 30	6	60	10.000	€ 2.500,00	€ 350,00
200	5, 1/6	16 + 16	6	35	10.000	€ 1.700,00	€ 256,00
200	5, 1/6	30 + 30	6	60	10.000	€ 3.160,00	€ 480,00
200	6, 1/7	16 + 16	6	35	10.000	€ 2.050,00	€ 290,00
200	6, 1/7	30 + 30	6	60	10.000	€ 3.800,00	€ 540,00



## Adattatore per seghe circolari

Adapter for saw blades with cylindrical shank

Adapter für kreissägen mit zylinderschaft

Adaptateur pour scies circulaires à queue cylindrique

Adaptador para sierra circular con mango cilíndrico

# ALC

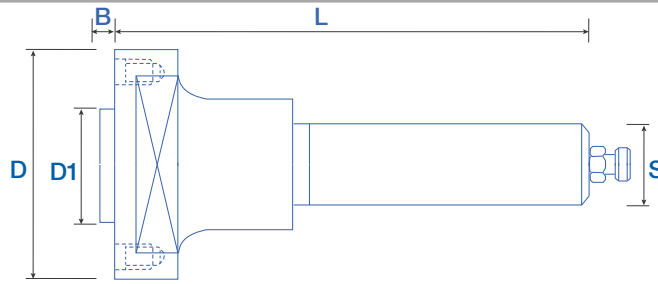

D	D1	B	S	L	Prezzo Price Preis Prix Precio
60	30	3,5	Ø 20x60	90	€ 260,00



## Adattatore HSK63F per seghe circolari

Saw blade adapters HSK63F

Adapter für kreissägen mit HSK63F

Adaptateur pour scies circulaires avec HSK63F

Adaptador para sierras circulares con HSK63F

# ALC1

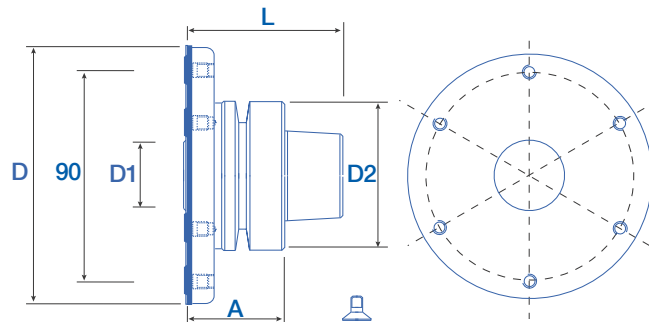

A	D	D1	D2	L	Prezzo Price Preis Prix Precio
40	110	30	63	65	€ 615,00
100	110	30	63	125	€ 695,00





## Frese per scanalature regolabili (con anelli distanziali)

Adjustable grooving cutters  
(with spacers)

Nutfräser, verstellbar  
(mit Zwischenringen)

Fraises à rainer extensibles  
(avec bagues de réglage)

Fresas para ranurar regulables  
(con anillos separadores)

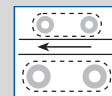

# F CR

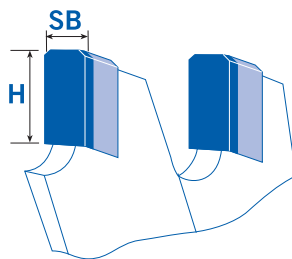
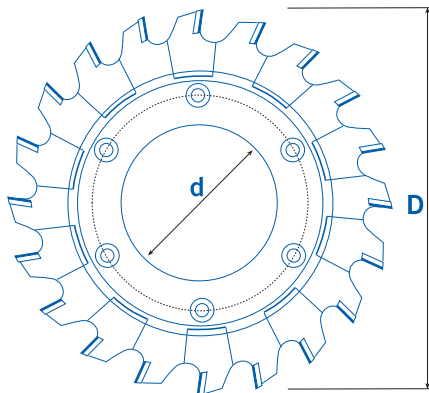

FZ-FA

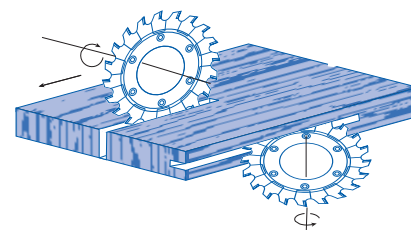

D	SB	Z	H	$\leftarrow \text{m/1'}$	$\text{⌚ n/max ⌚}$	Prezzo Price Preis Prix Precio	Affilatura Sharpening Erodieren Affûtage Afilado
125 - 200	3 - 5,5	4 + 4	6	4 / 5	11.000 / 8.000	€ 580,00	€ 125,00
125 - 200	4 - 7,5	4 + 4	6	4 / 5	11.000 / 8.000	€ 630,00	€ 150,00
125 - 200	5 - 9,5	4 + 4	6	4 / 5	11.000 / 8.000	€ 670,00	€ 165,00
125 - 200	6 - 11,5	4 + 4	6	4 / 5	11.000 / 8.000	€ 710,00	€ 180,00
125 - 200	8 - 15,5	4 + 4	6	4 / 5	11.000 / 8.000	€ 790,00	€ 200,00
125 - 200	10 - 19,5	4 + 4	6	4 / 5	11.000 / 8.000	€ 860,00	€ 220,00
125 - 200	3 - 5,5	6 + 6	6	4 / 5	11.000 / 8.000	€ 660,00	€ 150,00
125 - 200	4 - 7,5	6 + 6	6	4 / 5	11.000 / 8.000	€ 710,00	€ 220,00
125 - 200	5 - 9,5	6 + 6	6	4 / 5	11.000 / 8.000	€ 770,00	€ 235,00
125 - 200	6 - 11,5	6 + 6	6	4 / 5	11.000 / 8.000	€ 820,00	€ 250,00
125 - 200	8 - 15,5	6 + 6	6	4 / 5	11.000 / 8.000	€ 935,00	€ 275,00
125 - 200	10 - 19,5	6 + 6	6	4 / 5	11.000 / 8.000	€ 1.050,00	€ 300,00
125 - 200	3 - 5,5	8 + 8	6	6 / 10	11.000 / 8.000	€ 740,00	€ 170,00
125 - 200	4 - 7,5	8 + 8	6	6 / 10	11.000 / 8.000	€ 790,00	€ 200,00
125 - 200	5 - 9,5	8 + 8	6	6 / 10	11.000 / 8.000	€ 860,00	€ 215,00
125 - 200	6 - 11,5	8 + 8	6	6 / 10	11.000 / 8.000	€ 950,00	€ 230,00
125 - 200	8 - 15,5	8 + 8	6	6 / 10	11.000 / 8.000	€ 1.090,00	€ 250,00
125 - 200	10 - 19,5	8 + 8	6	6 / 10	11.000 / 8.000	€ 1.250,00	€ 275,00
150 - 200	3 - 5,5	10 + 10	6	6 / 10	6.000 / 9.000	€ 810,00	€ 200,00
150 - 200	4 - 7,5	10 + 10	6	6 / 10	6.000 / 9.000	€ 860,00	€ 215,00
150 - 200	5 - 9,5	10 + 10	6	6 / 10	6.000 / 9.000	€ 960,00	€ 230,00
150 - 200	6 - 11,5	10 + 10	6	6 / 10	6.000 / 9.000	€ 1.050,00	€ 250,00
150 - 200	8 - 15,5	10 + 10	6	6 / 10	6.000 / 9.000	€ 1.250,00	€ 270,00
150 - 200	10 - 19,5	10 + 10	6	6 / 10	6.000 / 9.000	€ 1.450,00	€ 295,00
150 - 200	3 - 5,5	12 + 12	6	6 / 10	6.000 / 9.000	€ 900,00	€ 230,00
150 - 200	4 - 7,5	12 + 12	6	6 / 10	6.000 / 9.000	€ 950,00	€ 225,00
150 - 200	5 - 9,5	12 + 12	6	6 / 10	6.000 / 9.000	€ 1.050,00	€ 250,00
150 - 200	6 - 11,5	12 + 12	6	6 / 10	6.000 / 9.000	€ 1.180,00	€ 280,00
150 - 200	8 - 15,5	12 + 12	6	6 / 10	6.000 / 9.000	€ 1.400,00	€ 295,00
150 - 200	10 - 19,5	12 + 12	6	6 / 10	6.000 / 9.000	€ 1.630,00	€ 310,00

Si possono costruire con mozzo a tazza.

You can build a hub with cup.

Sie können einen hub mit tasse bauen.

Vous pouvez construire un hub avec la cuvette.

Usted puede construir un centro con la taza.

+ € 370,00

H=Dia 5 mm - 8%  
H=Dia 4 mm -12%



**Frese per scanalature regolabili con spigolatore regolabile  
(con anelli distanziali)**

**Adjustable grooving cutters with adjustable spurs  
(with spacers)**

**Nutfräser verstellbar mit verstellbaren Fasen-Messern  
(mit Zwischenringen)**

**Fraises à rainier extensibles avec chanfreins extensibles  
(avec bagues de réglage)**

**Fresas para ranurar regulables con biselados regulables  
(con anillos separadores)**

**FCRS**

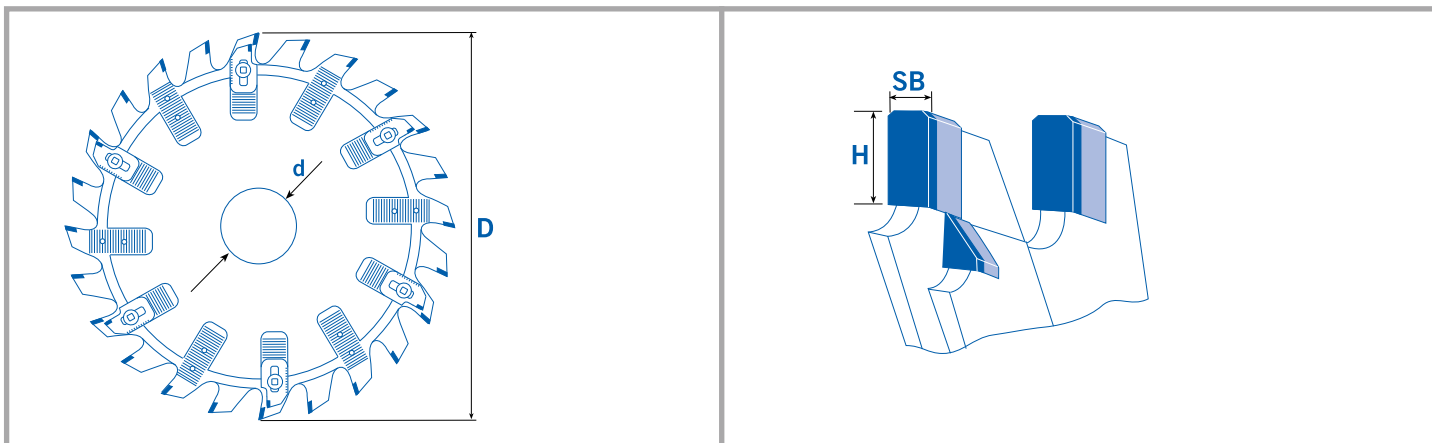

D	SB	Z	H	← m/1'	 n/max	Prezzo Price Preis Prix Precio	Affilatura Sharpening Erodieren Affûtage Afilado
120	3 - 5,5	6 + 6 + 3 + 3	6	3 / 6	5.000 / 9.000	€ 1.060,00	€ 260,00
120	4 - 7,5	6 + 6 + 3 + 3	6	3 / 6	5.000 / 9.000	€ 1.400,00	€ 340,00
120	6 - 11,5	6 + 6 + 3 + 3	6	3 / 6	5.000 / 9.000	€ 1.550,00	€ 405,00
160	3 - 5,5	8 + 8 + 4 + 4	6	4 / 8	5.000 / 9.000	€ 1.420,00	€ 350,00
160	4 - 7,5	8 + 8 + 4 + 4	6	4 / 8	5.000 / 9.000	€ 1.900,00	€ 450,00
160	6 - 11,5	8 + 8 + 4 + 4	6	4 / 8	5.000 / 9.000	€ 2.050,00	€ 540,00
180	3 - 5,5	10 + 10 + 5 + 5	6	7 / 10	5.000 / 9.000	€ 1.775,00	€ 435,00
180	4 - 7,5	10 + 10 + 5 + 5	6	7 / 10	5.000 / 9.000	€ 2.350,00	€ 565,00
180	6 - 11,5	10 + 10 + 5 + 5	6	7 / 10	5.000 / 9.000	€ 2.550,00	€ 675,00

Si possono costruire con mozzo a tazza.

You can build a hub with cup.

Sie können einen hub mit tasse bauen.

Vous pouvez construire un hub avec la cuvette.

Usted puede construir un centro con la taza.

+ € 370,00

Si possono costruire con ghiera regolabile con mozzo a tazza.

You can build a hub with adjustable cup with nut.

Sie können einen hub mit einstellbarer tasse mit mutter bauen.

Vous pouvez construire un hub avec une tasse réglable avec écrou.

Usted puede construir un centro con la taza ajustable con tuerca.

+ € 920,00



## Spigolatore fisso a corona per frese canali

DP spur for grooving cutters

DP Fase-Messer für Nutfräser

Chanfreins DP pour fraises à rainer

Biselado DP para fresas para ranurar

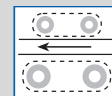

# FCS

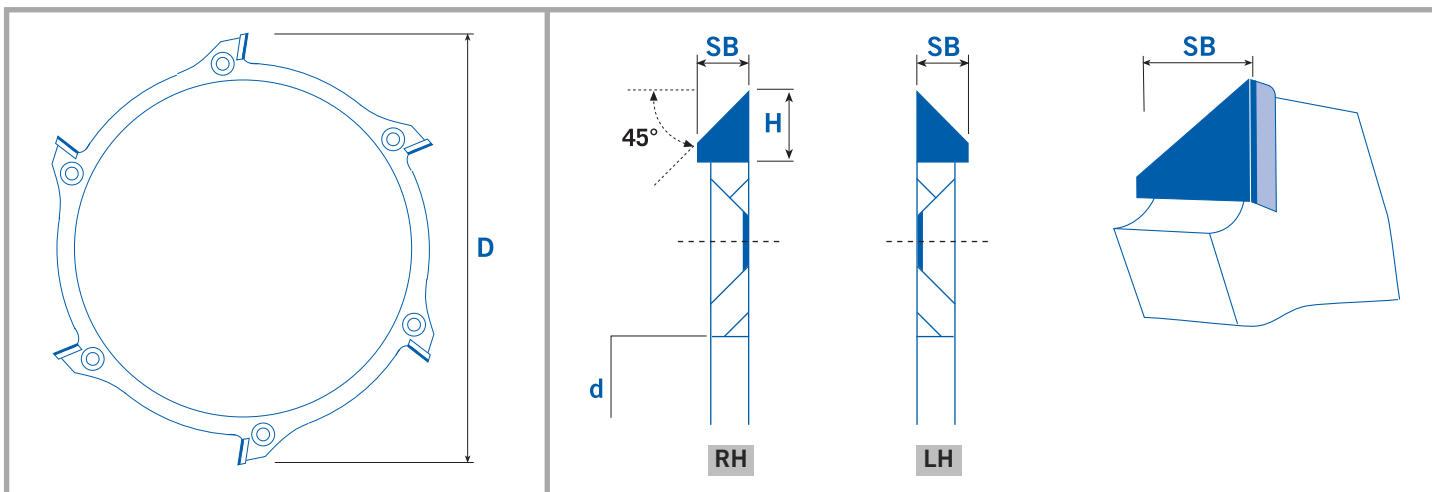

SB	Z	H	Prezzo Price Preis Prix Precio	Affilatura Sharpening Erodieren Affûtage Afilado
4	4	6	€ 300,00	€ 120,00
4	6	6	€ 360,00	€ 170,00
4	8	6	€ 480,00	€ 225,00

H=Dia 5 mm - 8%  
H=Dia 4 mm -12%

Da utilizzare in accoppiamento con le lame e le frese per canali.  
To be used together with grooving saw blades and grooving cutters.  
Zur Verwendung in Verbindung mit Nutsägeblätter und mit Nutfräser.  
A utiliser avec les lames et les fraises pour rainures.  
Para ser utilizadas en combinación con las sierras y las fresas para ranuras.



## Spigolatore registrabile fresa per canali

DP adjustable spur for grooving cutters

DP Fase-Messer verstellbar für Nutfräser

Chanfreins DP extensibles

Biselado DP regulable para fresas para ranurar

# SCB

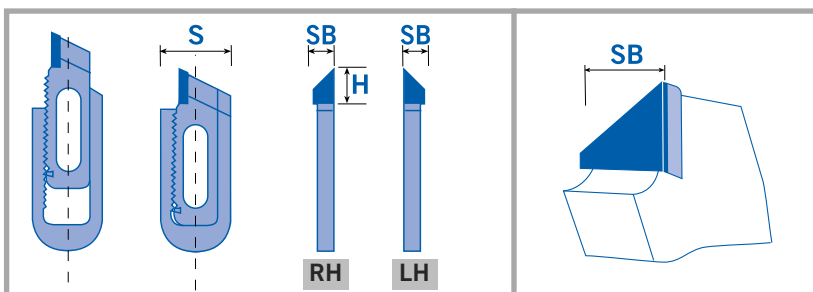

SB	Z	H	Prezzo Price Preis Prix Precio
4	1	6	€ 160,00



Frese per postforming/preforming  
Asportazione laminato superiore - motore orizzontale

Cutterheads for postforming/preforming  
Upper laminate removing - horizontal motor

Fräser für Postforming-und Preformingbearbeitung  
Abplattfräser für oberen Laminatschicht - Horizontalmotor

Fraises pour postforming/preforming  
Affleurage revêtement supérieur - moteur horizontal

Fresas para postforming/preforming  
Fresas para enrasar el laminado superior - eje horizontal

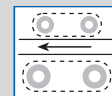

**FPH**

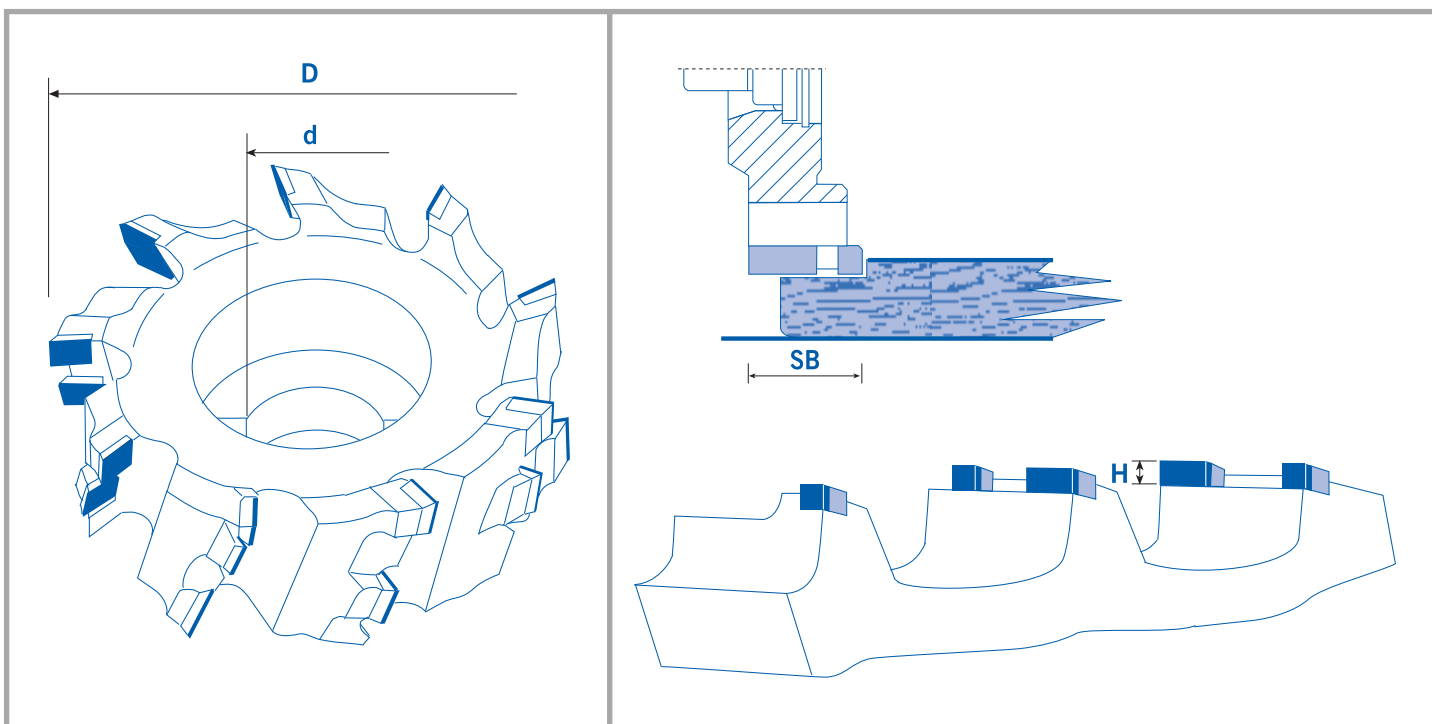

D	SB	Z	d	H	← m/1'	 n/max	Prezzo Price Preis Prix Precio	Affilatura Sharpening Erodieren Affûtage Afilado
70 - 100	20	6 + 3 + 3	16 / 20	5	20 / 30	12.000 / 24.000	€ 550,00	€ 250,00
70 - 100	20	6 + 3 + 3	HSK 25R / HSK 32R	5	20 / 30	12.000 / 24.000	€ 730,00	€ 250,00
70 - 100	20	9 + 3 + 3	16 / 20	5	30	12.000 / 24.000	€ 650,00	€ 290,00
70 - 100	20	9 + 3 + 3	HSK 25R / HSK 32R	5	30	12.000 / 24.000	€ 830,00	€ 290,00
70 - 100	25	6 + 3 + 3 + 3	16 / 20	5	25 / 30	12.000 / 24.000	€ 650,00	€ 265,00
70 - 100	25	6 + 3 + 3 + 3	HSK 25R / HSK 32R	5	25 / 30	12.000 / 24.000	€ 830,00	€ 265,00
70 - 100	25	9 + 3 + 3 + 3	16 / 20	5	30 / 35	12.000 / 24.000	€ 750,00	€ 315,00
70 - 100	25	9 + 3 + 3 + 3	HSK 25R / HSK 32R	5	30 / 35	12.000 / 24.000	€ 930,00	€ 315,00

H=Dia 4 mm - 8%

H=Dia 3 mm -12%

**ACCESSORI / SPARE PARTS / ZUBEHÖR / ACCESSOIRES / ACCESORIOS**

Vite / Screw / Schraube / Vis / Tornillo M 10 x 1,25 x 32

Spessore / Spacer / Abstandring / Bague de réglage / Espesor 18x25x1,0 DIN 988

Seeger / Clamping ring / Seegerring / Bague de sécurité / Anillo de retención 25x1,2 DIN 472

€ 14,00



**Frese per postforming/preforming  
Asportazione laminato superiore - motore verticale**

**Cutterheads for postforming/preforming  
Upper laminate removing - vertical motor**

**Fräser für Postforming-und Preformingbearbeitung  
Abplattfräser für oberen Laminatschicht - Vertikalmotor**

**Fraises pour postforming/preforming  
Affleurage revêtement supérieur - moteur vertical**

**Fresas para postforming/preforming  
Fresas para enrasar el laminado superior - eje vertical**

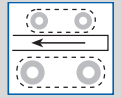

**FPV**

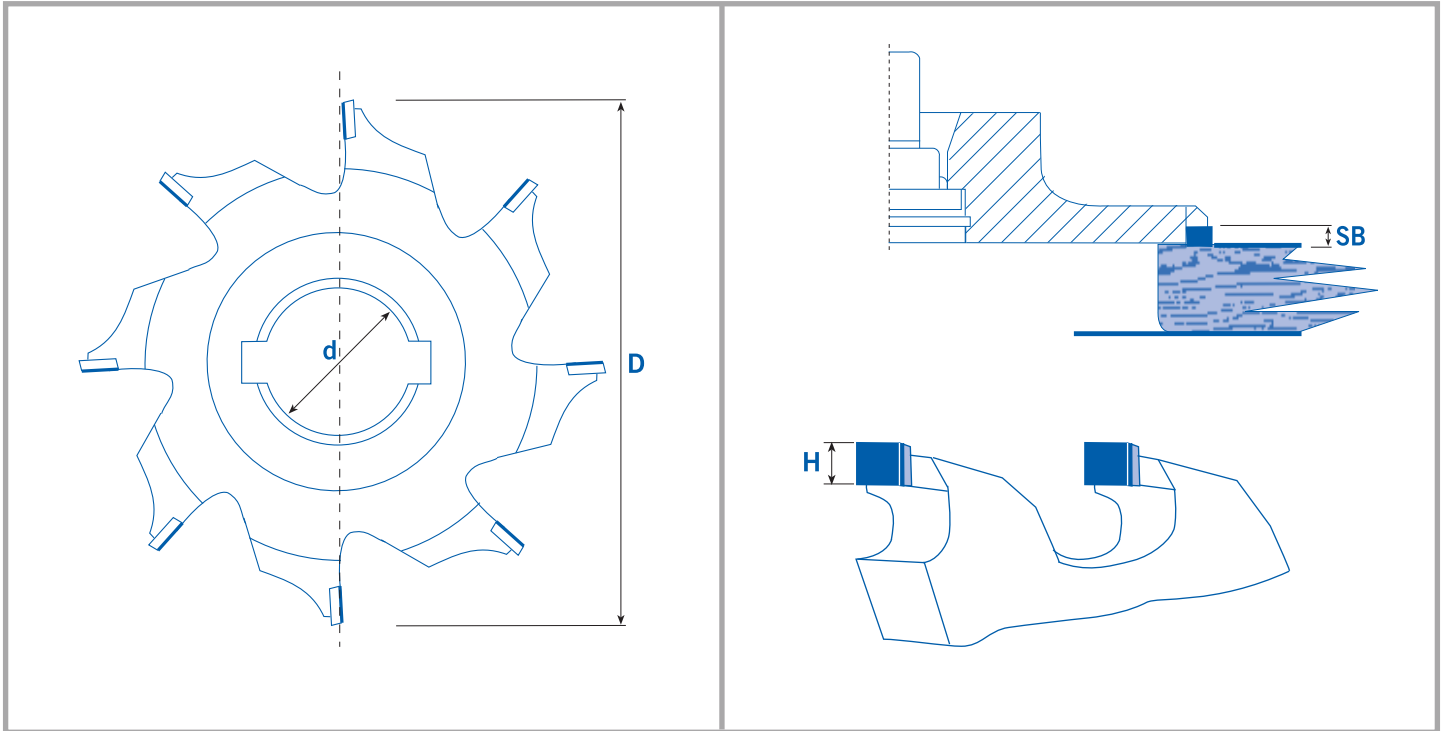

D	SB	Z	d	H	m/1'	n/max	Prezzo Price Preis Prix Precio	Affilatura Sharpening Erodieren Affûtage Afilado
100 - 150	6	6	16 / 20	5	20	21.000	€ 350,00	€ 170,00
100 - 150	6	6	HSK 25R / HSK 32R	5	20	21.000	€ 530,00	€ 170,00
100 - 150	6	8	16 / 20	5	25	21.000	€ 380,00	€ 230,00
100 - 150	6	8	HSK 25R / HSK 32R	5	25	21.000	€ 560,00	€ 230,00
100 - 150	6	12	16 / 20	5	35	21.000	€ 480,00	€ 330,00
100 - 150	6	12	HSK 25R / HSK 32R	5	35	21.000	€ 660,00	€ 330,00

H=Dia 4 mm - 8%  
H=Dia 3 mm -12%

**ACCESSORI / SPARE PARTS / ZUBEHÖR / ACCESSOIRES / ACCESORIOS**

Vite / Screw / Schraube / Vis / Tornillo M 10 x 1,25 x 32  
Spessore / Spacer / Abstandring / Bague de réglage / Espesor 18x25x1,0 DIN 988 — € 14,00  
Seeger / Clamping ring / Seegerring / Bague de sécurité / Anillo de retención 25x1,2 DIN 472



Frese per preforming  
Calibratura laminato inferiore

Cutterheads for preforming  
Bottom laminate cleaning

Fräser für Preformingbearbeitung  
Abplattfräser für unteren Laminatschicht

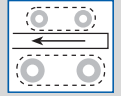

Fraises pour preforming  
Calibrage revêtement inférieur

Fresas para preforming  
Fresas para limpiar el laminado inferior

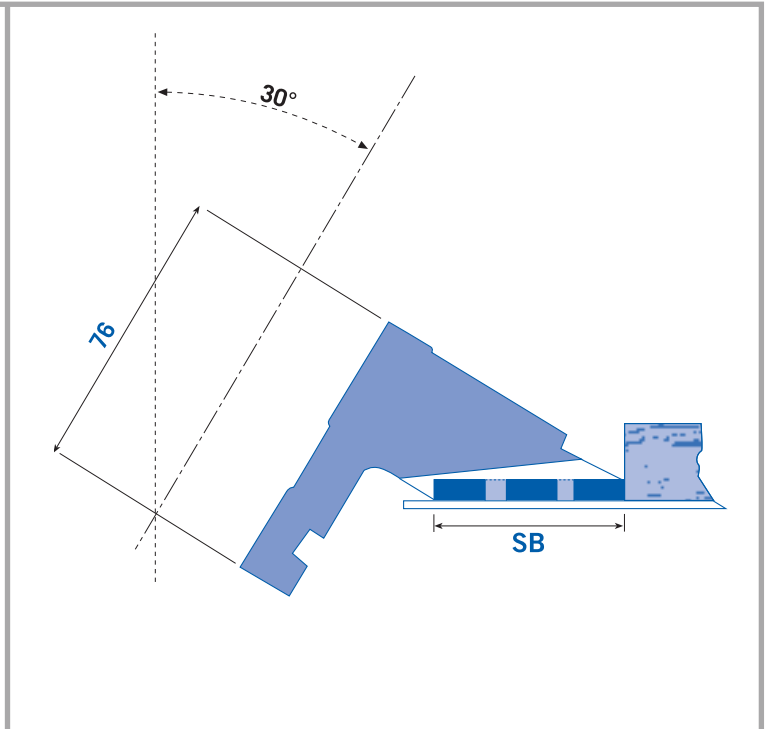
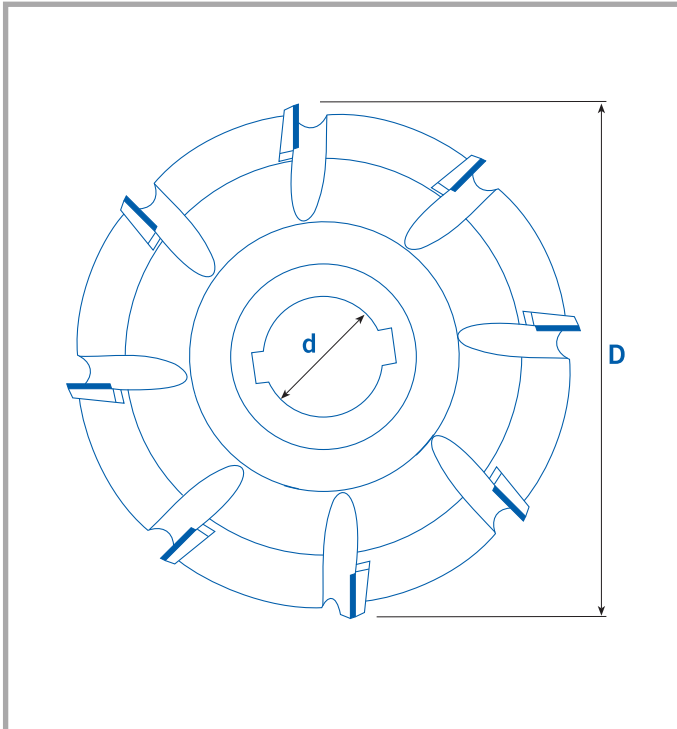

FPC



D	SB	Z	d	H	 m/1'	 n/max	Prezzo Price Preis Prix Precio	Affilatura Sharpening Erodieren Affûtage Afilado
200 - 220	12	8	35 / 40	5	25	9.000	€ 1.250,00	€ 260,00
200 - 220	26	8 + 4	35 / 40	5	25	9.000	€ 1.575,00	€ 300,00
200 - 220	30	8 + 4	35 / 40	5	25	9.000	€ 1.750,00	€ 350,00
200 - 220	35	8 + 4	35 / 40	5	25	9.000	€ 2.050,00	€ 400,00
200 - 220	45	8 + 4	35 / 40	5	25	9.000	€ 2.315,00	€ 450,00
200 - 220	54	8 + 4	35 / 40	5	25	9.000	€ 2.715,00	€ 500,00

H=Dia 6 mm +8%  
H=Dia 4 mm -8%



Frese per preforming  
Sagoma profilo inferiore

Cutterheads for preforming  
Bottom profile

Fräser für Preformingbearbeitung  
Profilabplattfräser, unten

Fraises pour preforming  
Profil inférieur

Fresas para preforming  
Perfil inferior

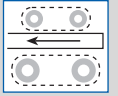

**FPI**

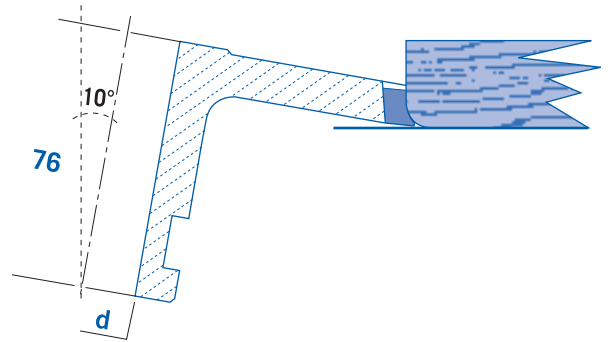
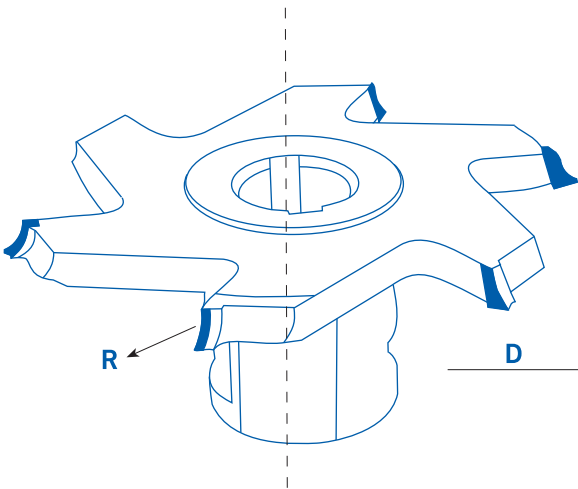

D	SB	Z	d	H	$\leftarrow$ m/1'	 n/max	Prezzo Price Preis Prix Precio	Affilatura Sharpening Erodieren Affûtage Afilado
180 - 220	4	6	35 / 40	5	25	10.000	€ 1.130,00	€ 250,00
180 - 220	5	6	35 / 40	5	25	10.000	€ 1.190,00	€ 270,00
180 - 220	6	6	35 / 40	5	25	10.000	€ 1.330,00	€ 290,00
180 - 220	6,5	6	35 / 40	5	25	10.000	€ 1.330,00	€ 290,00
180 - 220	7	6	35 / 40	5	25	10.000	€ 1.460,00	€ 390,00
180 - 220	7,5	6	35 / 40	5	25	10.000	€ 1.460,00	€ 390,00
180 - 220	8	6	35 / 40	5	25	10.000	€ 1.460,00	€ 390,00
180 - 220	9	6	35 / 40	5	25	10.000	€ 1.630,00	€ 460,00
180 - 220	9,5	6	35 / 40	5	25	10.000	€ 1.630,00	€ 460,00
180 - 220	10	6	35 / 40	5	25	10.000	€ 1.630,00	€ 460,00
180 - 220	11	6	35 / 40	5	25	10.000	€ 1.715,00	€ 500,00
180 - 220	12	6	35 / 40	5	25	10.000	€ 1.715,00	€ 500,00
180 - 220	12,5	6	35 / 40	5	25	10.000	€ 1.880,00	€ 540,00
180 - 220	14	6	35 / 40	5	25	10.000	€ 1.880,00	€ 540,00
180 - 220	15	6	35 / 40	5	25	10.000	€ 2.030,00	€ 540,00

H=Dia 6 mm +8%  
H=Dia 4 mm -8%



**Frese per preforming  
Incisione laminato inferiore**

**Cutterheads for preforming  
Bottom laminate engraving**

**Fräser für Preformingbearbeitung  
Ausspitzfräser für unteren Laminatschicht**

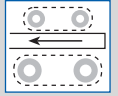

**Fraises pour preforming  
Incision revêtement inférieur**

**Fresas para preforming  
Incision laminado inferior**

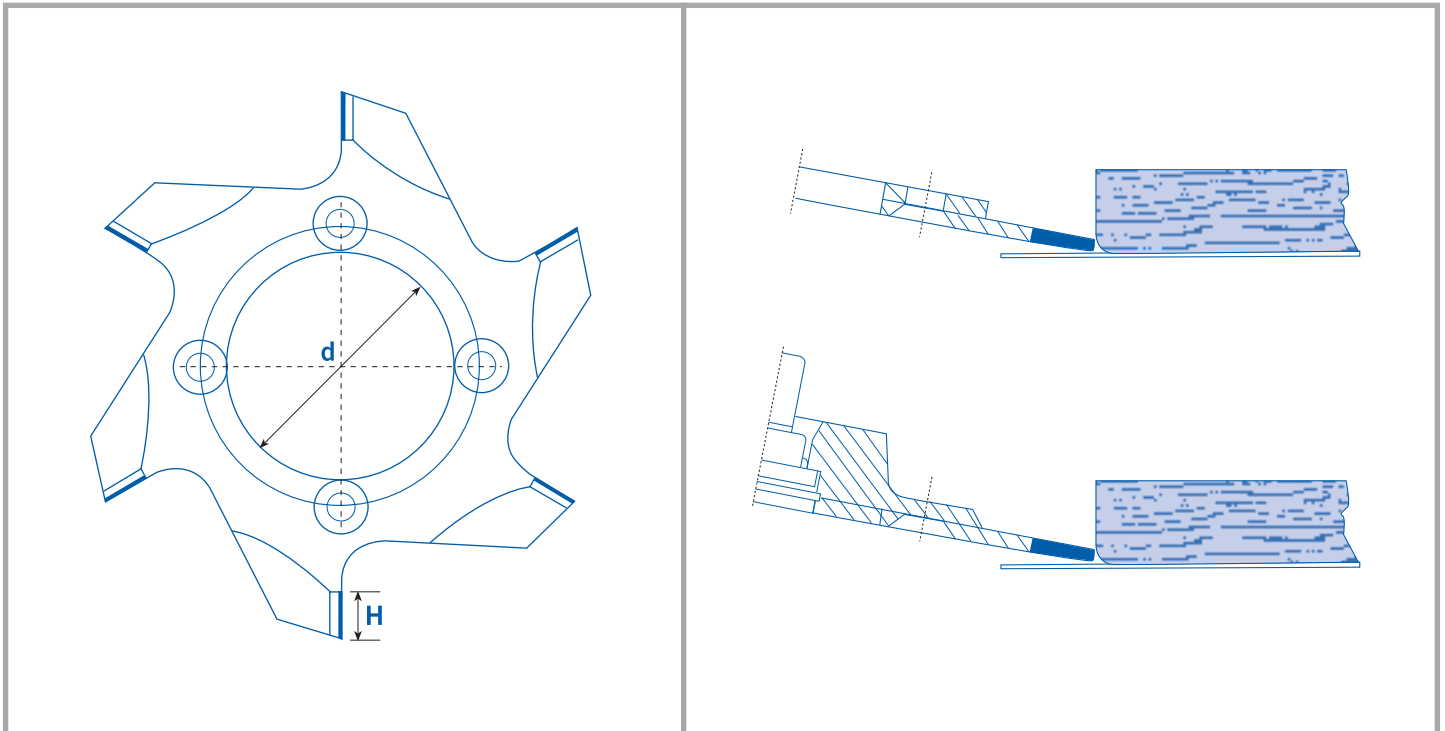

**FIL**



D	SB	Z	d	H			Prezzo Price Preis Prix Precio	Affilatura Sharpening Erodieren Affûtage Afilado
100 - 120	1,5	5	40 + 4	10	18 / 25	9.000 / 12.000	€ 425,00	€ 120,00
150	1,5	6	40 + 4	10	20 / 30	9.000 / 12.000	€ 510,00	€ 145,00





## Mozzi per montaggio frese incisione laminato

Mounting flanges for engraving cutterheads

Befestigungsflansche für Ausspitzfräser

Flanges de montage pour fraises incision

Bridas de sujeción para fresas incision

# MZP

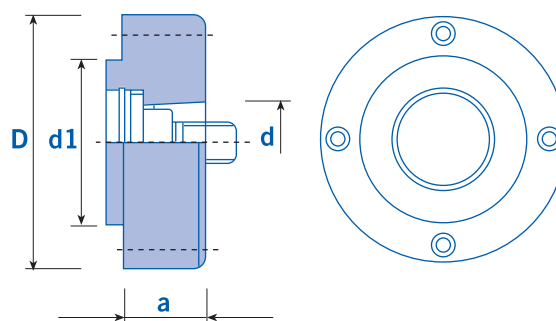
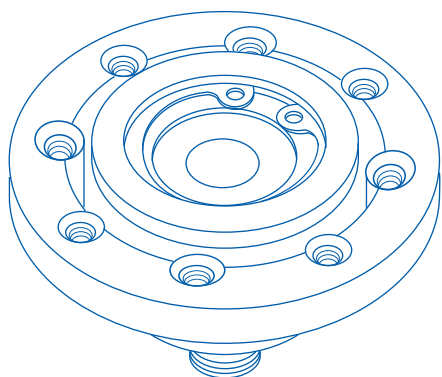
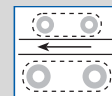

D	d	d1	a	Prezzo Price Preis Prix Precio
55	HSK 25R / HSK 32R	34	20	€ 375,00
62	HSK 25R / HSK 32R	40	20	€ 400,00
55	16 / 20	34	20	€ 255,00
62	16 / 20	40	20	€ 280,00

### ACCESSORI / SPARE PARTS / ZUBEHÖR / ACCESSOIRES / ACCESORIOS

Vite / Screw / Schraube / Vis / Tornillo M 10 x 1,25 x 32

Spessore / Spacer / Abstandring / Bague de réglage / Espesor 18x25x1,0 DIN 988

Seeger / Clamping ring / Seegerring / Bague de sécurité / Anillo de retención 25x1,2 DIN 472

Vite / Screw / Schraube / Vis / Tornillo M 5 x 10 T20

€ 16,00



**FPS**

**Frese per postforming/preforming  
Profilo superiore**



**Cutterheads for postforming/preforming  
Upper profile**

**Fräser für Postforming-und Preformingbearbeitung  
Profilabplattfräser, oben**

**Fraises pour postforming/preforming  
Profil supérieur**

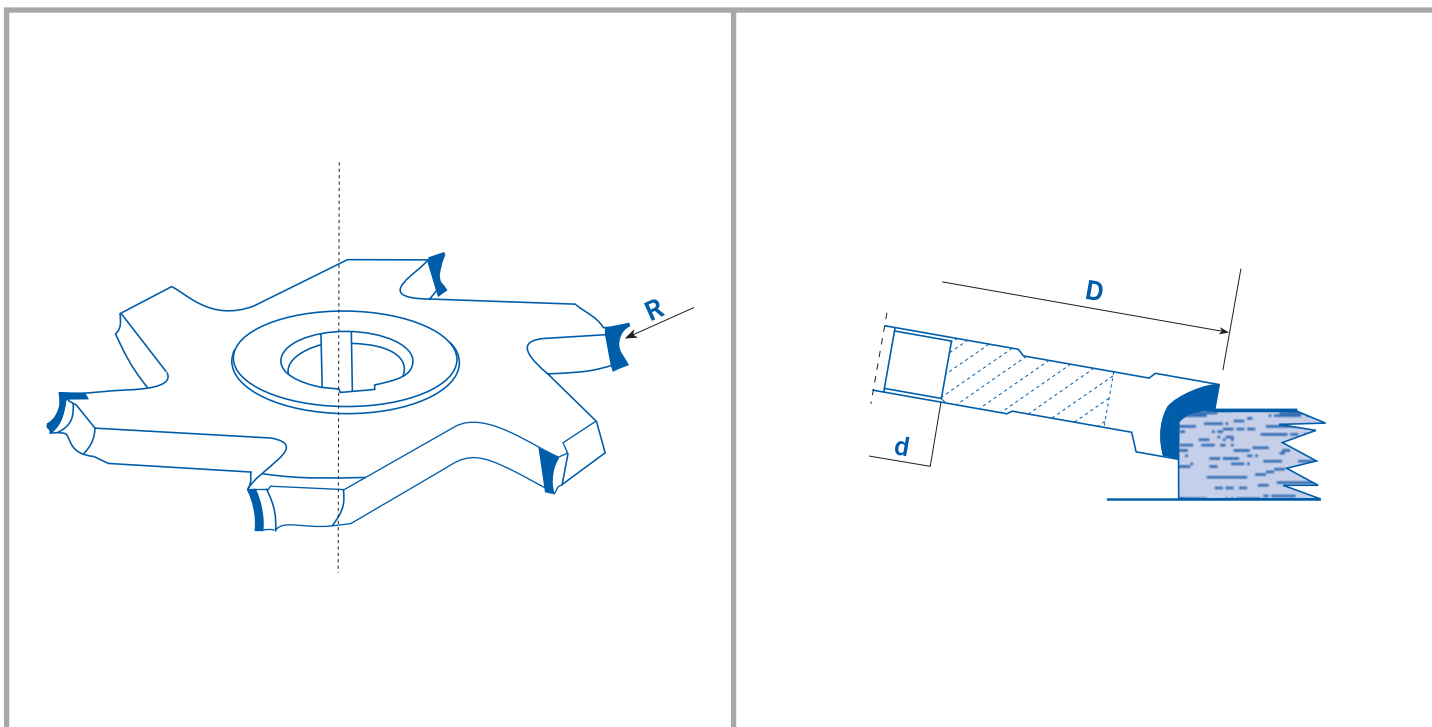
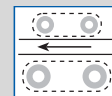
**Fresas para postforming/preforming  
Perfil superior**



D	SB	Z	d	H			Prezzo Price Preis Prix Precio	Affilatura Sharpening Erodieren Affûtage Afilado
150 - 200	3	4	35 / 40	5	15	9.000	€ 800,00	€ 250,00
150 - 200	4	4	35 / 40	5	15	9.000	€ 900,00	€ 250,00
150 - 200	6	4	35 / 40	5	15	9.000	€ 1.050,00	€ 320,00
150 - 200	8	4 + 4	35 / 40	5	15	9.000	€ 1.300,00	€ 350,00
150 - 200	10	4 + 4	35 / 40	5	15	9.000	€ 1.500,00	€ 400,00
150 - 200	12	4 + 4	35 / 40	5	15	9.000	€ 1.650,00	€ 450,00



**Frese per softforming**

**Softforming cutterheads**

**Fräser für Softformingbearbeitung**

**Fraises pour softforming**

**Fresas para softforming**

**FSF**

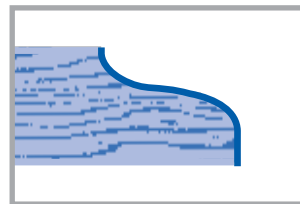
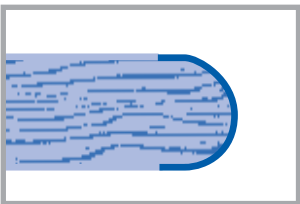
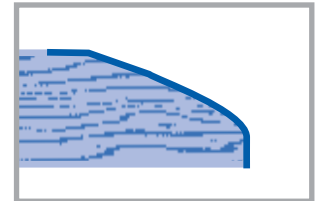
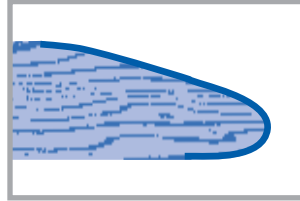
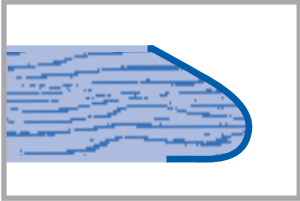
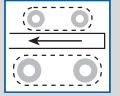

Il prezzo degli utensili dipende dalla loro geometria.  
Per ricevere la nostra offerta vi preghiamo di inviarci un disegno tecnico dell'utensile.

Price depends on tool geometry.  
Please provide a technical drawing of the tool to receive our offer.

Die Preise werden nach der Werkzeugen Geometrie berechnet, um ein Angebot zu bekommen,  
bitten wir um eine technische Zeichnung des Werkzeuges.

Les prix dépendent de la géométrie des outils.  
Pour recevoir notre devis nous vous prions de nous faire parvenir un plan technique de l'outil.

El precio depende de la geometría de las herramientas.  
Para obtener nuestra oferta rogamos nos envíen un dibujo técnico de la herramienta.



**FPK**

**Frese sagomate per lavorazione parquet**

**Profile cutterheads for flooring production**

**Profilfräser für Parkettbearbeitung**

**Fraises profilées pour usinage parquet**

**Fresas de perfil para producción pisos**

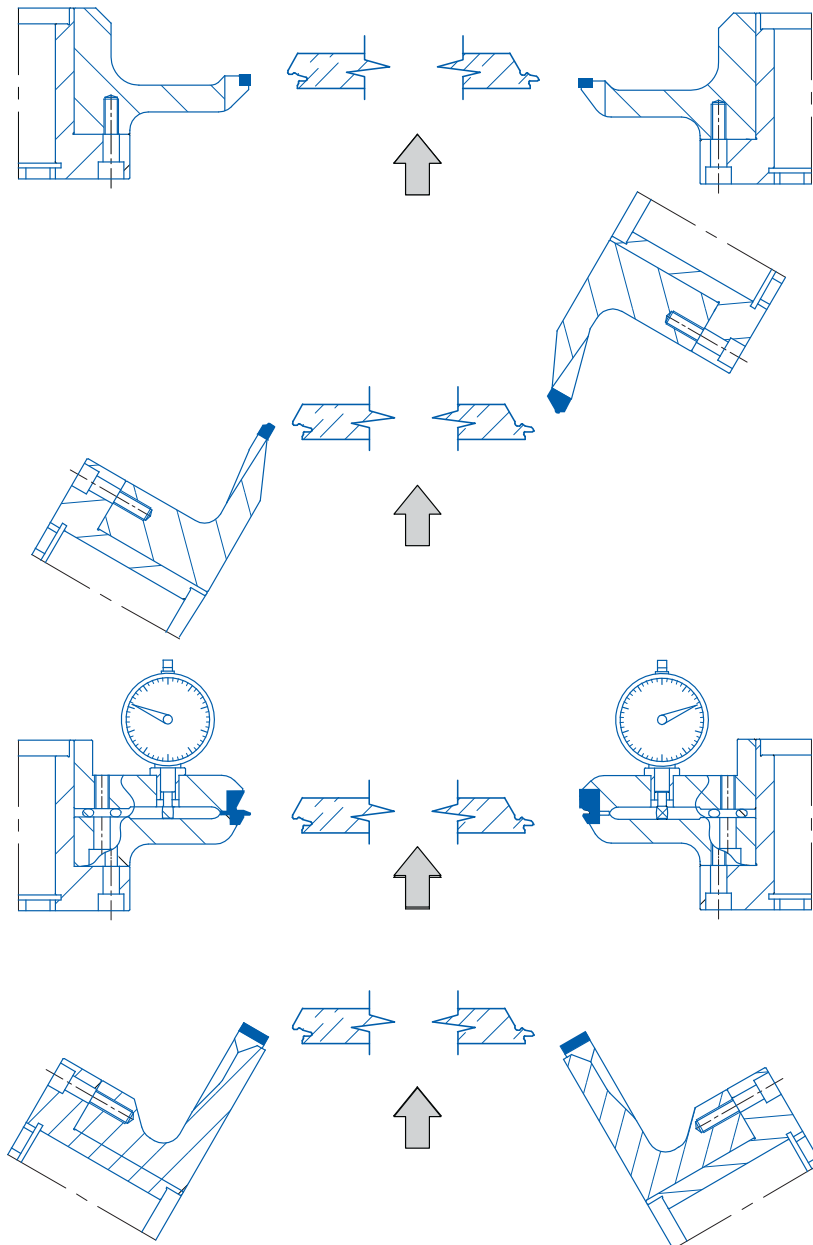
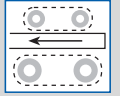

Per ricevere la nostra offerta, insieme al disegno tecnico del profilo da eseguire, occorre farci pervenire la configurazione della macchina ed informarci sulla velocità di avanzamento.

To receive our offer please provide the technical drawing of the profile together with the machine layout and inform the feed speed.

Um ein Angebot mit technischer Zeichnung des Profils zu bekommen, bitten wir um die Darstellung und Vorschubgeschwindigkeit der Maschine.

Pour recevoir notre devis, ainsi que le plan du profil à exécuter, nous vous prions de nous faire parvenir la configuration de la machine et de nous communiquer la vitesse d'avance.

Para recibir nuestra oferta, junto con el diseño técnico del perfil, les rogamos enviarnos la configuración de la máquina y comunicarnos la velocidad de avance.



Frese a profilo

Profile cutterheads

Profilfräser

Fraises profilées

Fresas de perfil

FRP

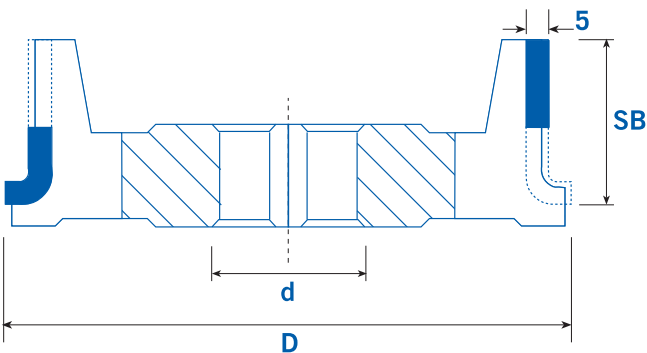
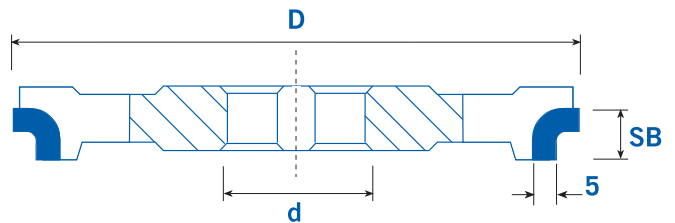
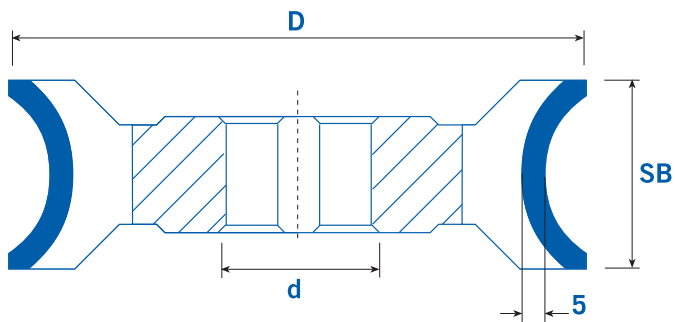
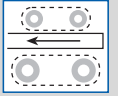

Il prezzo degli utensili dipende dalla loro geometria.  
Per ricevere la nostra offerta vi preghiamo di inviarci un disegno tecnico dell'utensile.

Price depends on tool geometry.  
Please provide a technical drawing of the tool to receive our offer.

Die Preise werden nach der Werkzeugen Geometrie berechnet, um ein Angebot zu bekommen,  
bitten wir um eine technische Zeichnung des Werkzeuges.

Les prix dépendent de la géométrie des outils.  
Pour recevoir notre devis nous vous prions de nous faire parvenir un plan technique de l'outil.

El precio depende de la geometría de las herramientas.  
Para obtener nuestra oferta rogamos nos envíen un dibujo técnico de la herramienta.



**PUG1**

**Frese per pantografo  
Z=1+1 versione Eco**

**Router cutters  
Z=1+1 Eco version**

**Oberfräser  
Z=1+1 Eco-Version**

**Fraises à défoncer  
Z=1+1 version Econome**

**Fresas para CN  
Z=1+1 versión Eco**

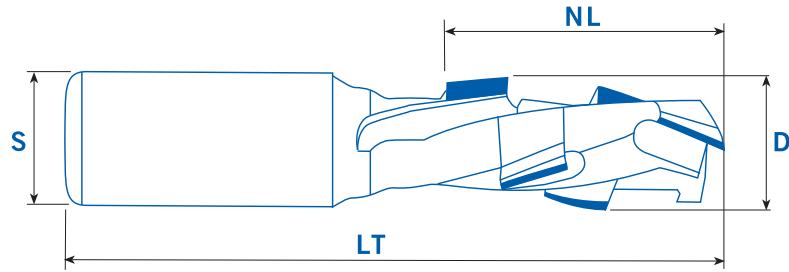
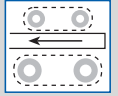

D	NL	S	LT	PL	H	$\leftarrow \text{m/1'}$	 n/max	Prezzo Price Preis Prix Precio	Affilatura Sharpening Erodieren Affûtage Afilado
10	25	12 x 45	75	3 DP + 1 HW	2,5	4 / 8	18.000 / 24.000	€ 95,00	€ 48,00
10	34	12 x 45	85	4 DP + 1 HW	2,5	4 / 8	18.000 / 24.000	€ 126,00	€ 64,00
12	25	12 x 45	75	3 DP + 1 HW	2,5	4 / 8	18.000 / 24.000	€ 95,00	€ 48,00
12	34	12 x 45	85	4 DP + 1 HW	2,5	4 / 8	18.000 / 24.000	€ 126,00	€ 64,00
14	25	16 x 50	85	3 DP + 1 HW	2,5	4 / 8	18.000 / 24.000	€ 95,00	€ 48,00
14	34	16 x 50	94	4 DP + 1 HW	2,5	4 / 8	18.000 / 24.000	€ 126,00	€ 64,00
16	25	16 x 50	85	3 DP + 1 HW	2,5	4 / 8	18.000 / 24.000	€ 95,00	€ 48,00
16	34	16 x 50	94	4 DP + 1 HW	2,5	4 / 8	18.000 / 24.000	€ 126,00	€ 64,00
16	43	16 x 50	103	5 DP + 1 HW	2,5	4 / 8	18.000 / 24.000	€ 158,00	€ 80,00
18	25	20 x 50	85	3 DP + 1 HW	2,5	4 / 8	18.000 / 24.000	€ 95,00	€ 48,00
18	34	20 x 50	94	4 DP + 1 HW	2,5	4 / 8	18.000 / 24.000	€ 126,00	€ 64,00
18	43	20 x 50	103	5 DP + 1 HW	2,5	4 / 8	18.000 / 24.000	€ 158,00	€ 80,00
20	25	20 x 50	85	3 DP + 1 HW	2,5	4 / 8	18.000 / 24.000	€ 95,00	€ 48,00
20	34	20 x 50	94	4 DP + 1 HW	2,5	4 / 8	18.000 / 24.000	€ 126,00	€ 64,00
20	43	20 x 50	103	5 DP + 1 HW	2,5	4 / 8	18.000 / 24.000	€ 158,00	€ 80,00
20	52	20 x 50	112	6 DP + 1 HW	2,5	4 / 8	18.000 / 24.000	€ 190,00	€ 95,00
20	61	20 x 50	121	7 DP + 1 HW	2,5	4 / 8	18.000 / 24.000	€ 222,00	€ 111,00

Placchetta DP in testa  
PCD tip to plunge  
PKD-Bohrschneide  
Coupe en bout diamant  
Corte de taladrado en DP

— € 50,00



# PUG1A

**Frese per pantografo**  
**Z=1+1 affilabile**

**Router cutters**  
**Z=1+1 with large resharpening area**

**Oberfräser**  
**Z=1+1 nachschärfbar**

**Fraises à défoncer**  
**Z=1+1 affûtable**

**Fresas para CN**  
**Z=1+1 con amplia zona de reafilado**

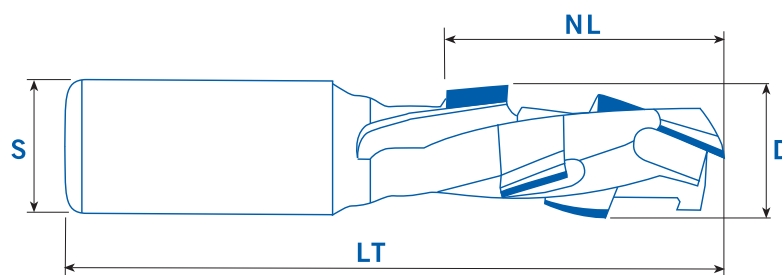
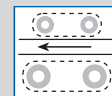

D	NL	S	LT	PL	H	$\leftarrow \text{m/1}^{\circ}$	 n/max	Prezzo Price Preis Prix Precio	Affilatura Sharpening Erodieren Affûtage Afilado
16	25	16 x 50	85	3 DP + 1 HW	4,0	4 / 8	18.000 / 24.000	€ 130,00	€ 48,00
16	34	16 x 50	94	4 DP + 1 HW	4,0	4 / 8	18.000 / 24.000	€ 170,00	€ 64,00
16	43	16 x 50	103	5 DP + 1 HW	4,0	4 / 8	18.000 / 24.000	€ 210,00	€ 80,00
18	25	20 x 50	85	3 DP + 1 HW	4,5	4 / 8	18.000 / 24.000	€ 130,00	€ 48,00
18	34	20 x 50	94	4 DP + 1 HW	4,5	4 / 8	18.000 / 24.000	€ 170,00	€ 64,00
18	43	20 x 50	103	5 DP + 1 HW	4,5	4 / 8	18.000 / 24.000	€ 210,00	€ 80,00
20	25	20 x 50	85	3 DP + 1 HW	4,5	4 / 8	18.000 / 24.000	€ 130,00	€ 48,00
20	34	20 x 50	94	4 DP + 1 HW	4,5	4 / 8	18.000 / 24.000	€ 170,00	€ 64,00
20	43	20 x 50	103	5 DP + 1 HW	4,5	4 / 8	18.000 / 24.000	€ 210,00	€ 80,00
20	52	20 x 50	112	6 DP + 1 HW	4,5	4 / 8	18.000 / 24.000	€ 255,00	€ 95,00
20	61	20 x 50	121	7 DP + 1 HW	4,5	4 / 8	18.000 / 24.000	€ 295,00	€ 111,00

Placchetta DP in testa  
 PCD tip to plunge  
 PKD-Bohrschneide  
 Coupe en bout diamant  
 Corte de taladrado en DP

— € 50,00



# PUG1B

**Frese per pantografo**  
**Z=1+1 assialità 45° affilabile**



**Router cutters**  
**Z=1+1 axiality 45° with large resharpening area**

**Oberfräser**  
**Z=1+1 achswinkel 45° nachschärfbar**

**Fraises à défoncer**  
**Z=1+1 angle axial 45° affûtable**

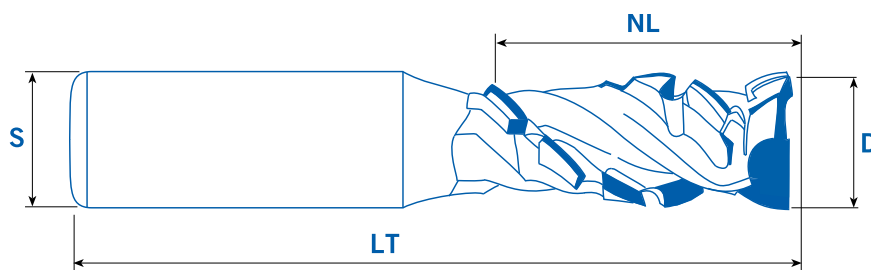
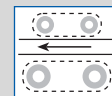
**Fresas para CN**  
**Z=1+1 corte assial 45° con amplia zona de reafilado**



D	NL	S	LT	PL	H	 m/1'	 n/max	Prezzo Price Preis Prix Precio	Affilatura Sharpening Erodieren Affûtage Afilado
20	22	20 x 50	82	4 + 1 DP	4	4 / 8	18.000 / 24.000	€ 265,00	€ 105,00
20	27	20 x 50	87	5 + 1 DP	4	4 / 8	18.000 / 24.000	€ 300,00	€ 130,00
20	32	20 x 50	92	6 + 1 DP	4	4 / 8	18.000 / 24.000	€ 335,00	€ 150,00
20	37	20 x 50	97	7 + 1 DP	4	4 / 8	18.000 / 24.000	€ 370,00	€ 170,00
20	42	20 x 50	102	8 + 1 DP	4	4 / 8	18.000 / 24.000	€ 406,00	€ 195,00
20	47	20 x 50	107	9 + 1 DP	4	4 / 8	18.000 / 24.000	€ 440,00	€ 215,00
20	52	20 x 50	112	10 + 1 DP	4	4 / 8	18.000 / 24.000	€ 476,00	€ 240,00
20	57	20 x 50	117	11 + 1 DP	4	4 / 8	18.000 / 24.000	€ 511,00	€ 260,00

Placchetta DP in testa  
PCD tip to plunge  
PKD-Bohrschneide  
Coupe en bout diamant  
Corte de taladrado en DP

€ 60,00





# PUG1C

Frese per pantografo  
Z=1+1 assialità 54° affilabile

Router cutters  
Z=1+1 axiality 54° with large resharpening area

Oberfräser  
Z=1+1 achswinkel 54° nachschärfbar

Fraises à défoncer  
Z=1+1 angle axial 54° affûtable

Fresas para CN  
Z=1+1 corte assial 54° con amplia zona de reafilado

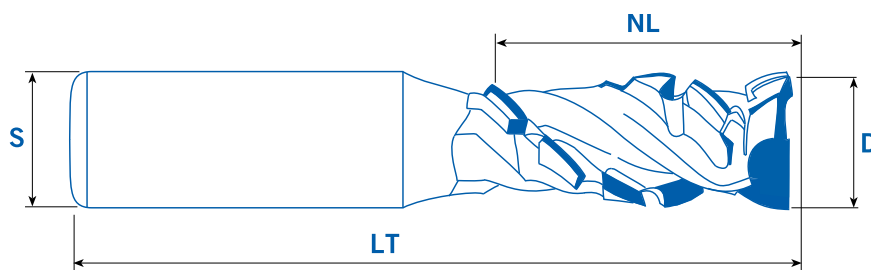
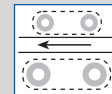

D	NL	S	LT	PL	H	 m/1'	 n/max	Prezzo Price Preis Prix Precio	Affilatura Sharpening Erodieren Affûtage Afilado
20	25	20 x 50	85	5 + 1 DP	4	4 / 8	18.000 / 24.000	€ 303,00	€ 150,00
20	30	20 x 50	90	6 + 1 DP	4	4 / 8	18.000 / 24.000	€ 338,00	€ 175,00
20	35	20 x 50	95	7 + 1 DP	4	4 / 8	18.000 / 24.000	€ 373,00	€ 200,00
20	40	20 x 50	100	8 + 1 DP	4	4 / 8	18.000 / 24.000	€ 408,00	€ 225,00
20	45	20 x 50	105	9 + 1 DP	4	4 / 8	18.000 / 24.000	€ 444,00	€ 250,00
20	50	20 x 50	110	10 + 1 DP	4	4 / 8	18.000 / 24.000	€ 480,00	€ 275,00
20	55	20 x 50	115	11 + 1 DP	4	4 / 8	18.000 / 24.000	€ 515,00	€ 300,00

Placchetta DP in testa  
PCD tip to plunge  
PKD-Bohrschneide  
Coupe en bout diamant  
Corte de taladrado en DP

€ 60,00



**PUG2**

Frese per pantografo  
Z=2+2 versione Eco

Router cutters  
Z=2+2 Eco version

Oberfräser  
Z=2+2 Eco-Version

Fraises à défoncer  
Z=2+2 version Econome

Fresas para CN  
Z=2+2 versión Eco

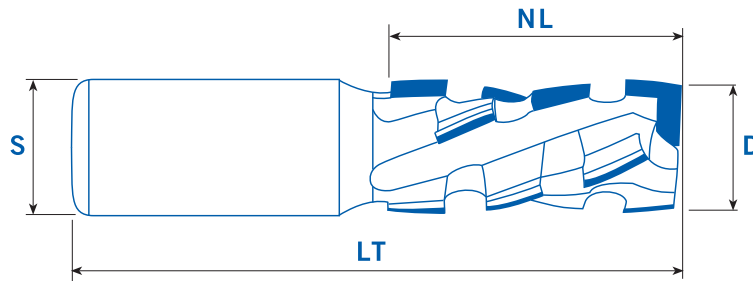
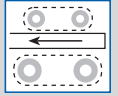

D	NL	S	LT	PL	H	$\leftarrow \text{m/1}^{\circ}$	 n/max	Prezzo Price Preis Prix Precio	Affilatura Sharpening Erodieren Affûtage Afilado
10	25	12 x 45	75	6 DP + 1 HW	2,5	5 / 15	18.000 / 24.000	€ 190,00	€ 96,00
10	34	12 x 45	85	8 DP + 1 HW	2,5	5 / 15	18.000 / 24.000	€ 255,00	€ 128,00
12	25	12 x 45	75	6 DP + 1 HW	2,5	5 / 15	18.000 / 24.000	€ 190,00	€ 96,00
12	34	12 x 45	85	8 DP + 1 HW	2,5	5 / 15	18.000 / 24.000	€ 255,00	€ 128,00
14	25	16 x 50	85	6 DP + 1 HW	2,5	5 / 15	18.000 / 24.000	€ 190,00	€ 96,00
14	34	16 x 50	94	8 DP + 1 HW	2,5	5 / 15	18.000 / 24.000	€ 255,00	€ 128,00
16	25	16 x 50	85	6 DP + 1 HW	2,5	5 / 15	18.000 / 24.000	€ 190,00	€ 96,00
16	34	16 x 50	94	8 DP + 1 HW	2,5	5 / 15	18.000 / 24.000	€ 255,00	€ 128,00
16	43	16 x 50	103	10 DP + 1 HW	2,5	5 / 15	18.000 / 24.000	€ 315,00	€ 160,00
18	25	20 x 50	85	6 DP + 1 HW	2,5	5 / 15	18.000 / 24.000	€ 190,00	€ 96,00
18	34	20 x 50	94	8 DP + 1 HW	2,5	5 / 15	18.000 / 24.000	€ 255,00	€ 128,00
18	43	20 x 50	103	10 DP + 1 HW	2,5	5 / 15	18.000 / 24.000	€ 315,00	€ 160,00
20	25	20 x 50	85	6 DP + 1 HW	2,5	5 / 15	18.000 / 24.000	€ 190,00	€ 96,00
20	34	20 x 50	94	8 DP + 1 HW	2,5	5 / 15	18.000 / 24.000	€ 255,00	€ 128,00
20	43	20 x 50	103	10 DP + 1 HW	2,5	5 / 15	18.000 / 24.000	€ 315,00	€ 160,00
20	52	20 x 50	112	12 DP + 1 HW	2,5	5 / 15	18.000 / 24.000	€ 380,00	€ 190,00
20	61	20 x 50	121	14 DP + 1 HW	2,5	5 / 15	18.000 / 24.000	€ 445,00	€ 222,00

Placchetta DP in testa  
PCD tip to plunge  
PKD-Bohrschneide  
Coupe en bout diamant  
Corte de taladrado en DP

— € 50,00



**PUG2A**

**Frese per pantografo  
Z=2+2 affilabile**

**Router cutters  
Z=2+2 with large resharpening area**

**Oberfräser  
Z=2+2 nachschärfbar**

**Fraises à défoncer  
Z=2+2 affûtable**

**Fresas para CN  
Z=2+2 con amplia zona de reafilado**

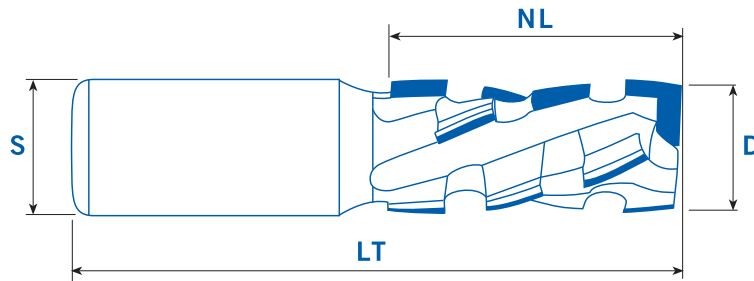
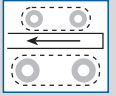

D	NL	S	LT	PL	H	← m/1'	 n/max	Prezzo Price Preis Prix Precio	Affilatura Sharpening Erodieren Affûtage Afilado
16	25	16 x 50	85	6 DP + 1 HW	4,0	13 / 20	18.000 / 24.000	€ 255,00	€ 96,00
16	34	16 x 50	94	8 DP + 1 HW	4,0	13 / 20	18.000 / 24.000	€ 336,00	€ 128,00
16	43	16 x 50	103	10 DP + 1 HW	4,0	13 / 20	18.000 / 24.000	€ 420,00	€ 160,00
18	25	20 x 50	85	6 DP + 1 HW	4,5	13 / 20	18.000 / 24.000	€ 255,00	€ 96,00
18	34	20 x 50	94	8 DP + 1 HW	4,5	13 / 20	18.000 / 24.000	€ 336,00	€ 128,00
18	43	20 x 50	103	10 DP + 1 HW	4,5	13 / 20	18.000 / 24.000	€ 420,00	€ 160,00
20	25	20 x 50	85	6 DP + 1 HW	4,5	13 / 20	18.000 / 24.000	€ 255,00	€ 96,00
20	34	20 x 50	94	8 DP + 1 HW	4,5	13 / 20	18.000 / 24.000	€ 336,00	€ 128,00
20	43	20 x 50	103	10 DP + 1 HW	4,5	13 / 20	18.000 / 24.000	€ 420,00	€ 160,00
20	52	20 x 50	112	12 DP + 1 HW	4,5	13 / 20	18.000 / 24.000	€ 505,00	€ 180,00
20	61	20 x 50	121	14 DP + 1 HW	4,5	13 / 20	18.000 / 24.000	€ 590,00	€ 222,00

Placchetta DP in testa  
PCD tip to plunge  
PKD-Bohrschneide  
Coupe en bout diamant  
Corte de taladrado en DP

— € 50,00



**PUG3**

Frese per pantografo ad alta velocità  
Z=2+2 (3 divisioni) versione Eco

High speed router cutters  
Z=2+2 (3 wings) Eco version

Hochleistungsoberfräser  
Z=2+2 (3 Flügel) Eco-Version

Fraises à défoncer à haute vitesse  
Z=2+2 (3 divisions) version Econome

Fresas para CN de alto rendimiento  
Z=2+2 (3 divisiones) versión Eco

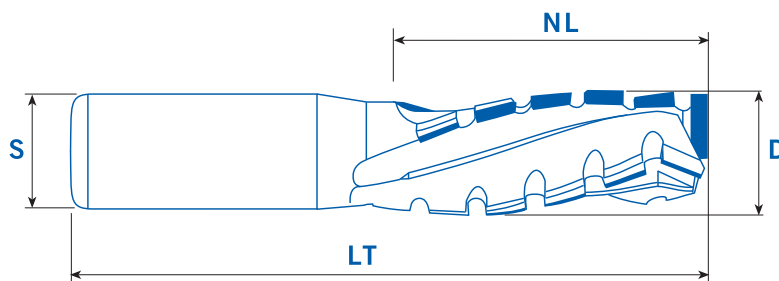
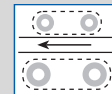

D	NL	S	LT	PL	H	$\leftarrow \text{m/1'}$	 n/max	Prezzo Price Preis Prix Precio	Affilatura Sharpening Erodieren Affûtage Afilado
16	29	16 x 50	89	5 DP+2 DP+1 HW	2,5	10 / 15	18.000/24.000	€ 230,00	€ 120,00
16	34	16 x 50	94	7 DP+2 DP+1 HW	2,5	10 / 15	18.000/24.000	€ 265,00	€ 155,00
16	46	16 x 50	106	12 DP+2 DP+1 HW	2,5	10 / 15	18.000/24.000	€ 325,00	€ 240,00
18	34	20 x 50	95	7 DP+2 DP+1 HW	2,5	10 / 15	18.000/24.000	€ 265,00	€ 155,00
18	46	20 x 50	106	12 DP+2 DP+1 HW	2,5	10 / 15	18.000/24.000	€ 325,00	€ 240,00
20	52	20 x 50	112	13 DP+2 DP+1 HW	2,5	10 / 15	18.000/24.000	€ 350,00	€ 260,00
20	57	20 x 50	117	15 DP+2 DP+1 HW	2,5	10 / 15	18.000/24.000	€ 380,00	€ 290,00
22	66	20 x 50	126	18 DP+2 DP+1 HW	2,5	10 / 15	18.000/24.000	€ 420,00	€ 340,00



**PUG3A**

Frese per pantografo ad alta velocità  
Z=2+2 (3 divisioni) affilabile

High speed router cutters  
Z=2+2 (3 wings) with large resharpening area

Hochleistungsoberfräser  
Z=2+2 (3 Flügel) nachschlärffbar

Fraises à défoncer à haute vitesse  
Z=2+2 (3 divisions) affûtable

Fresas para CN de alto rendimiento  
Z=2+2 (3 divisiones) con amplia zona de reafilado

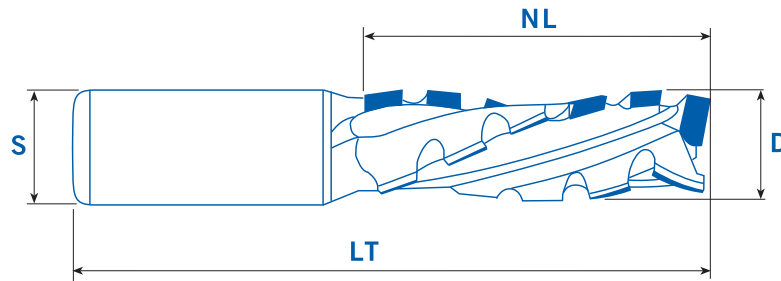
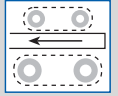

D	NL	S	LT	PL	H	← m/1'	 n/max	Prezzo Price Preis Prix Precio	Affilatura Sharpening Erodieren Affûtage Afilado
20	29	20 x 50	89	7 DP + 1 DP	4,5	10 / 15	18.000 / 24.000	€ 330,00	€ 120,00
20	34	20 x 50	94	9 DP + 1 DP	4,5	10 / 15	18.000 / 24.000	€ 385,00	€ 155,00
20	46	20 x 50	106	12 DP + 1 DP	4,5	10 / 15	18.000 / 24.000	€ 475,00	€ 170,00
20	52	20 x 50	112	13 DP + 1 DP	4,5	10 / 15	18.000 / 24.000	€ 530,00	€ 205,00
22	57	20 x 50	117	15 DP + 1 DP	4,5	10 / 15	18.000 / 24.000	€ 560,00	€ 230,00
22	65	20 x 50	125	17 DP + 1 DP	4,5	10 / 15	18.000 / 24.000	€ 615,00	€ 260,00



**PRU2**

**Frese per pantografo ad alto rendimento mod. RICCIO  
Z=2+2 versione Eco**

**High performance router cutters mod. RICCIO  
Z=2+2 Eco version**

**Hochleistungsoberfräser mod. RICCIO  
Z=2+2 Eco-Version**

**Fraises à défoncer à haute vitesse mod. RICCIO  
Z=2+2 version Econome**

**Fresas para CN de alto rendimiento mod. RICCIO  
Z=2+2 versión Eco**

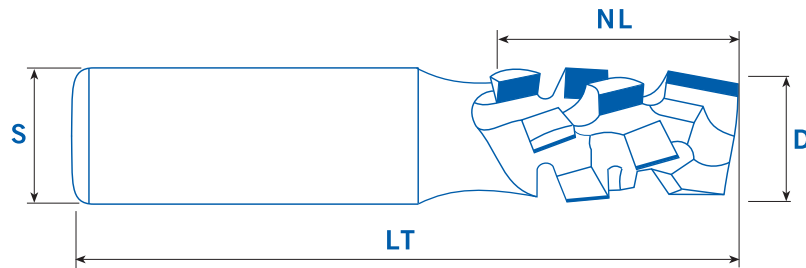
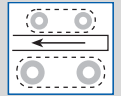

D	NL	S	LT	PL	H	← m/1'	n/max	Prezzo Price Preis Prix Precio	Affilatura Sharpening Erodieren Affûtage Afilado
16	25	16 x 50	85	6 DP + 2 DP + 1 HW	2,5	20 / 30	18.000 / 24.000	€ 215,00	€ 110,00
16	30	16 x 50	90	8 DP + 2 DP + 1 HW	2,5	20 / 30	18.000 / 24.000	€ 240,00	€ 135,00
16	35	16 x 50	95	10 DP + 2 DP + 1 HW	2,5	20 / 30	18.000 / 24.000	€ 266,00	€ 160,00
16	40	16 x 50	100	12 DP + 2 DP + 1 HW	2,5	20 / 30	18.000 / 24.000	€ 295,00	€ 185,00
16	45	16 x 50	105	14 DP + 2 DP + 1 HW	2,5	20 / 30	18.000 / 24.000	€ 320,00	€ 210,00
18	25	20 x 50	85	6 DP + 2 DP + 1 HW	2,5	20 / 30	18.000 / 24.000	€ 215,00	€ 110,00
18	30	20 x 50	90	8 DP + 2 DP + 1 HW	2,5	20 / 30	18.000 / 24.000	€ 240,00	€ 135,00
18	35	20 x 50	95	10 DP + 2 DP + 1 HW	2,5	20 / 30	18.000 / 24.000	€ 266,00	€ 160,00
18	40	20 x 50	100	12 DP + 2 DP + 1 HW	2,5	20 / 30	18.000 / 24.000	€ 295,00	€ 185,00
18	45	20 x 50	105	14 DP + 2 DP + 1 HW	2,5	20 / 30	18.000 / 24.000	€ 320,00	€ 210,00
18	50	20 x 50	110	16 DP + 2 DP + 1 HW	2,5	20 / 30	18.000 / 24.000	€ 345,00	€ 240,00
18	55	20 x 50	115	18 DP + 2 DP + 1 HW	2,5	20 / 30	18.000 / 24.000	€ 370,00	€ 265,00
20	25	20 x 50	85	6 DP + 2 DP + 1 HW	2,5	20 / 30	18.000 / 24.000	€ 215,00	€ 110,00
20	30	20 x 50	90	8 DP + 2 DP + 1 HW	2,5	20 / 30	18.000 / 24.000	€ 240,00	€ 135,00
20	35	20 x 50	95	10 DP + 2 DP + 1 HW	2,5	20 / 30	18.000 / 24.000	€ 266,00	€ 160,00
20	40	20 x 50	100	12 DP + 2 DP + 1 HW	2,5	20 / 30	18.000 / 24.000	€ 295,00	€ 185,00
20	45	20 x 50	105	14 DP + 2 DP + 1 HW	2,5	20 / 30	18.000 / 24.000	€ 320,00	€ 210,00
20	50	20 x 50	110	16 DP + 2 DP + 1 HW	2,5	20 / 30	18.000 / 24.000	€ 345,00	€ 240,00
20	55	20 x 50	115	18 DP + 2 DP + 1 HW	2,5	20 / 30	18.000 / 24.000	€ 370,00	€ 265,00
25	25	25 x 55	95	6 DP + 2 DP + 1 HW	2,5	20 / 30	18.000 / 24.000	€ 215,00	€ 110,00
25	30	25 x 55	100	8 DP + 2 DP + 1 HW	2,5	20 / 30	18.000 / 24.000	€ 240,00	€ 135,00
25	35	25 x 55	105	10 DP + 2 DP + 1 HW	2,5	20 / 30	18.000 / 24.000	€ 266,00	€ 160,00
25	40	25 x 55	110	12 DP + 2 DP + 1 HW	2,5	20 / 30	18.000 / 24.000	€ 295,00	€ 185,00
25	45	25 x 55	115	14 DP + 2 DP + 1 HW	2,5	20 / 30	18.000 / 24.000	€ 320,00	€ 210,00
25	50	25 x 55	120	16 DP + 2 DP + 1 HW	2,5	20 / 30	18.000 / 24.000	€ 345,00	€ 240,00
25	55	25 x 55	125	18 DP + 2 DP + 1 HW	2,5	20 / 30	18.000 / 24.000	€ 370,00	€ 265,00
25	60	25 x 55	130	20 DP + 2 DP + 1 HW	2,5	20 / 30	18.000 / 24.000	€ 400,00	€ 290,00

Placchetta DP in testa / PCD tip to plunge / PKD-Bohrschneide / Coupe en bout diamant / Corte de taladrado en DP - € 50,00



# PRU3

**Frese per pantografo ad alto rendimento mod. RICCIO  
Z=3+3 versione Eco**



**High performance router cutters mod. RICCIO  
Z=3+3 Eco version**

**HochleistungsOberfräser mod. RICCIO  
Z=3+3 Eco-Version**

**Fraises à défoncer à haute vitesse mod. RICCIO  
Z=3+3 version Econome**

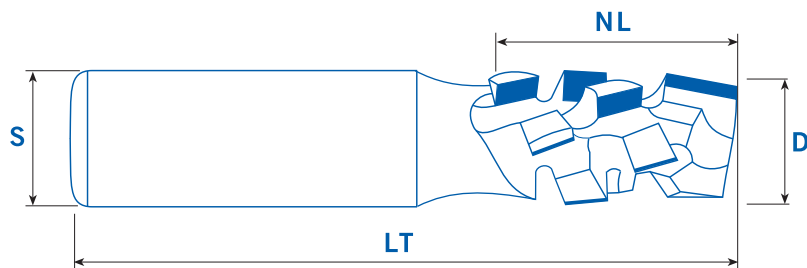
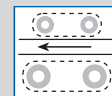
**Fresas para CN de alto rendimiento mod. RICCIO  
Z=3+3 versión Eco**



D	NL	S	LT	PL	H	 m/1'	 n/max	Prezzo Price Preis Prix Precio	Affilatura Sharpening Erodieren Affûtage Afilado
25	25	25 x 55	95	9 DP + 3 DP + 1 HW	2,5	20 / 30	18.000 / 24.000	€ 275,00	€ 160,00
25	30	25 x 55	100	12 DP + 3 DP + 1 HW	2,5	20 / 30	18.000 / 24.000	€ 315,00	€ 200,00
25	35	25 x 55	105	15 DP + 3 DP + 1 HW	2,5	20 / 30	18.000 / 24.000	€ 355,00	€ 240,00
25	40	25 x 55	110	18 DP + 3 DP + 1 HW	2,5	20 / 30	18.000 / 24.000	€ 395,00	€ 280,00
25	45	25 x 55	115	21 DP + 3 DP + 1 HW	2,5	20 / 30	18.000 / 24.000	€ 435,00	€ 315,00
25	50	25 x 55	120	24 DP + 3 DP + 1 HW	2,5	20 / 30	18.000 / 24.000	€ 470,00	€ 355,00
25	55	25 x 55	125	27 DP + 3 DP + 1 HW	2,5	20 / 30	18.000 / 24.000	€ 510,00	€ 395,00
25	60	25 x 55	130	30 DP + 3 DP + 1 HW	2,5	20 / 30	18.000 / 24.000	€ 550,00	€ 435,00
25	65	25 x 55	135	33 DP + 3 DP + 1 HW	2,5	20 / 30	18.000 / 24.000	€ 590,00	€ 475,00

Placchetta DP in testa  
PCD tip to plunge  
PKD-Bohrschneide  
Coupe en bout diamant  
Corte de taladrado en DP

€ 50,00



**Frese per pantografo ad alto rendimento mod. RICCIO  
Z=2+2 affilabile**

**High performance router cutters mod. RICCIO  
Z=2+2 with large resharpening area**

**Hochleistungsbohrer mod. RICCIO  
Z=2+2 nachschärfbar**

**Fraises à défoncer à haute vitesse mod. RICCIO  
Z=2+2 affûtable**

**Fresas para CN de alto rendimiento mod. RICCIO  
Z=2+2 con amplia zona de reafilado**

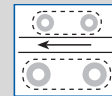

**PRD2**

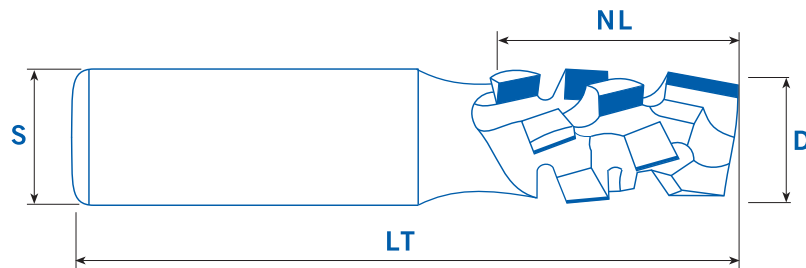

D	NL	S	LT	PL	H	$\leftarrow \text{m/1}^{\circ}$	 n/max	Prezzo Price Preis Prix Precio	Affilatura Sharpening Erodieren Affûtage Afilado
18	25	20 x 50	85	6 DP + 2 DP + 1 HW	4,0	12 / 30	18.000 / 24.000	€ 290,00	€ 110,00
18	30	20 x 50	90	8 DP + 2 DP + 1 HW	4,0	12 / 30	18.000 / 24.000	€ 330,00	€ 135,00
18	35	20 x 50	95	10 DP + 2 DP + 1 HW	4,0	12 / 30	18.000 / 24.000	€ 370,00	€ 160,00
18	40	20 x 50	100	12 DP + 2 DP + 1 HW	4,0	12 / 30	18.000 / 24.000	€ 415,00	€ 185,00
18	45	20 x 50	105	14 DP + 2 DP + 1 HW	4,0	12 / 30	18.000 / 24.000	€ 455,00	€ 210,00
18	50	20 x 50	110	16 DP + 2 DP + 1 HW	4,0	12 / 30	18.000 / 24.000	€ 495,00	€ 240,00
18	55	20 x 50	115	18 DP + 2 DP + 1 HW	4,0	12 / 30	18.000 / 24.000	€ 538,00	€ 265,00
20	25	20 x 50	85	6 DP + 2 DP + 1 HW	4,5	12 / 30	18.000 / 24.000	€ 315,00	€ 110,00
20	30	20 x 50	90	8 DP + 2 DP + 1 HW	4,5	12 / 30	18.000 / 24.000	€ 360,00	€ 135,00
20	35	20 x 50	95	10 DP + 2 DP + 1 HW	4,5	12 / 30	18.000 / 24.000	€ 405,00	€ 160,00
20	40	20 x 50	100	12 DP + 2 DP + 1 HW	4,5	12 / 30	18.000 / 24.000	€ 455,00	€ 185,00
20	45	20 x 50	105	14 DP + 2 DP + 1 HW	4,5	12 / 30	18.000 / 24.000	€ 500,00	€ 210,00
20	50	20 x 50	110	16 DP + 2 DP + 1 HW	4,5	12 / 30	18.000 / 24.000	€ 546,00	€ 240,00
20	55	20 x 50	115	18 DP + 2 DP + 1 HW	4,5	12 / 30	18.000 / 24.000	€ 595,00	€ 265,00
25	25	25 x 55	95	6 DP + 2 DP + 1 HW	4,5	12 / 30	18.000 / 24.000	€ 290,00	€ 110,00
25	30	25 x 55	100	8 DP + 2 DP + 1 HW	4,5	12 / 30	18.000 / 24.000	€ 330,00	€ 135,00
25	35	25 x 55	105	10 DP + 2 DP + 1 HW	4,5	12 / 30	18.000 / 24.000	€ 370,00	€ 160,00
25	40	25 x 55	110	12 DP + 2 DP + 1 HW	4,5	12 / 30	18.000 / 24.000	€ 415,00	€ 185,00
25	45	25 x 55	115	14 DP + 2 DP + 1 HW	4,5	12 / 30	18.000 / 24.000	€ 455,00	€ 210,00
25	50	25 x 55	120	16 DP + 2 DP + 1 HW	4,5	12 / 30	18.000 / 24.000	€ 495,00	€ 240,00
25	55	25 x 55	125	18 DP + 2 DP + 1 HW	4,5	12 / 30	18.000 / 24.000	€ 538,00	€ 265,00
25	60	25 x 55	130	20 DP + 2 DP + 1 HW	4,5	12 / 30	18.000 / 24.000	€ 640,00	€ 290,00

Placchetta DP in testa  
PCD tip to plunge  
PKD-Bohrschneide  
Coupe en bout diamant  
Corte de taladrado en DP

€ 50,00





# PRD3

Frese per pantografo ad alto rendimento mod. RICCIO  
Z=3+3 affilabile



High performance router cutters mod. RICCIO  
Z=3+3 with large resharpening area

Hochleistungsbohrer mod. RICCIO  
Z=3+3 nachschärfbar

Fraises à défoncer à haute vitesse mod. RICCIO  
Z=3+3 affûtable

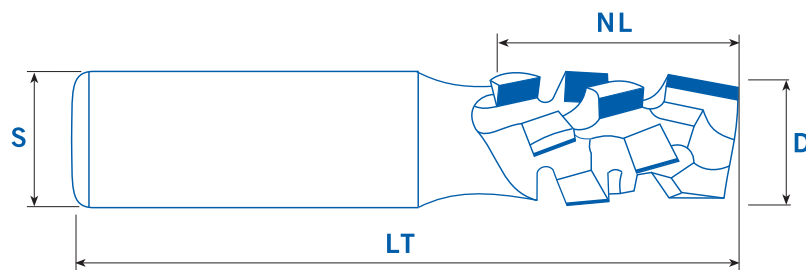
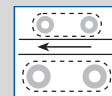
Fresas para CN de alto rendimiento mod. RICCIO  
Z=3+3 con amplia zona de reafilado



D	NL	S	LT	PL	H			Prezzo Price Preis Prix Precio	Affilatura Sharpening Erodieren Affûtage Afilado
25	25	25 x 55	95	9 DP + 3 DP + 1 HW	4,5	12 / 20	18.000 / 24.000	€ 425,00	€ 160,00
25	30	25 x 55	100	12 DP + 3 DP + 1 HW	4,5	12 / 20	18.000 / 24.000	€ 495,00	€ 200,00
25	35	25 x 55	105	15 DP + 3 DP + 1 HW	4,5	12 / 20	18.000 / 24.000	€ 565,00	€ 240,00
25	40	25 x 55	110	18 DP + 3 DP + 1 HW	4,5	12 / 20	18.000 / 24.000	€ 635,00	€ 280,00
25	45	25 x 55	115	21 DP + 3 DP + 1 HW	4,5	12 / 20	18.000 / 24.000	€ 705,00	€ 315,00
25	50	25 x 55	120	24 DP + 3 DP + 1 HW	4,5	12 / 20	18.000 / 24.000	€ 775,00	€ 365,00
25	55	25 x 55	125	27 DP + 3 DP + 1 HW	4,5	12 / 20	18.000 / 24.000	€ 845,00	€ 395,00
25	60	25 x 55	130	30 DP + 3 DP + 1 HW	4,5	12 / 20	18.000 / 24.000	€ 915,00	€ 435,00
25	65	25 x 55	135	33 DP + 3 DP + 1 HW	4,5	12 / 20	18.000 / 24.000	€ 985,00	€ 475,00

Placchetta DP in testa  
PCD tip to plunge  
PKD-Bohrschneide  
Coupe en bout diamant  
Corte de taladrado en DP

€ 50,00



Frese per pantografo ad alto rendimento  
Z=2+2 assialità 45°

High speed router cutters  
Z=2+2 axiality 45°

Hochleistungsoberfräser  
Z=2+2 Achswinkel 45°

Fraises à défoncer à haute vitesse  
Z=2+2 angle axial 45°

Fresas para CN de alto rendimiento  
Z=2+2 corte axial 45°

**PRA2**

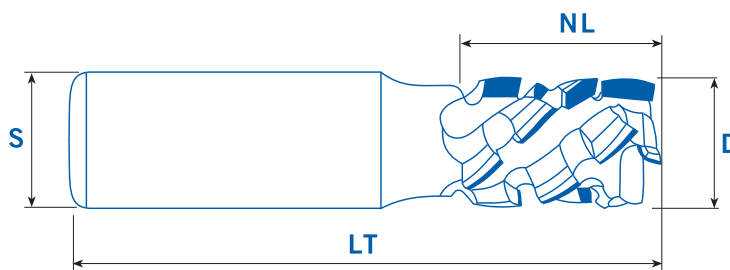
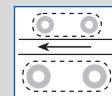

D	NL	S	LT	PL	H	$\leftarrow \text{m/1'}$	$\ominus \text{ n/max } \oplus$	Prezzo Price Preis Prix Precio	Affilatura Sharpening Erodieren Affûtage Afilado
22	28	20 x 50	86	8 DP + 2 DP + 1 DP	4,5	15 / 30	18.000 / 24.000	€ 460,00	€ 190,00
22	33	20 x 50	91	10 DP + 2 DP + 1 DP	4,5	15 / 30	18.000 / 24.000	€ 520,00	€ 230,00
22	38	20 x 50	96	12 DP + 2 DP + 1 DP	4,5	15 / 30	18.000 / 24.000	€ 585,00	€ 260,00
22	43	20 x 50	101	14 DP + 2 DP + 1 DP	4,5	15 / 30	18.000 / 24.000	€ 645,00	€ 290,00
25	48	25 x 55	116	16 DP + 2 DP + 1 DP	4,5	15 / 30	18.000 / 24.000	€ 705,00	€ 330,00
25	53	25 x 55	121	18 DP + 2 DP + 1 DP	4,5	15 / 30	18.000 / 24.000	€ 765,00	€ 360,00
25	58	25 x 55	126	20 DP + 2 DP + 1 DP	4,5	15 / 30	18.000 / 24.000	€ 830,00	€ 395,00
25	63	25 x 55	131	22 DP + 2 DP + 1 DP	4,5	15 / 30	18.000 / 24.000	€ 890,00	€ 430,00
25	68	25 x 55	136	24 DP + 2 DP + 1 DP	4,5	15 / 30	18.000 / 24.000	€ 950,00	€ 460,00



Frese per pantografo ad alto rendimento  
Z=2+2 assialità 54°

High speed router cutters  
Z=2+2 axiality 54°

Hochleistungsobrerfräser  
Z=2+2 Achswinkel 54°

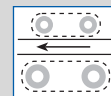

Fraises à défoncer à haute vitesse  
Z=2+2 angle axial 54°

Fresas para CN de alto rendimiento  
Z=2+2 corte axial 54°

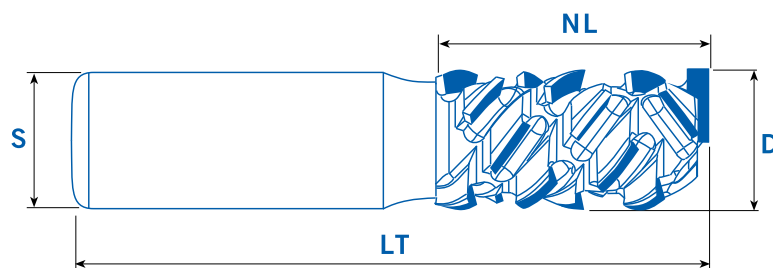

**PRA3**

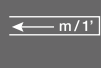

D	NL	S	LT	PL	H			Prezzo Price Preis Prix Precio	Affilatura Sharpening Erodieren Affûtage Afilado
25	20	25 x 55	89	8 DP + 1 DP	5	15 / 30	18.000 / 24.000	€ 500,00	€ 240,00
25	25	25 x 55	94	10 DP + 1 DP	5	15 / 30	18.000 / 24.000	€ 590,00	€ 290,00
25	30	25 x 55	99	12 DP + 1 DP	5	15 / 30	18.000 / 24.000	€ 675,00	€ 350,00
25	35	25 x 55	104	14 DP + 1 DP	5	15 / 30	18.000 / 24.000	€ 765,00	€ 400,00
25	40	25 x 55	109	16 DP + 1 DP	5	15 / 30	18.000 / 24.000	€ 850,00	€ 450,00
25	45	25 x 55	114	18 DP + 1 DP	5	15 / 30	18.000 / 24.000	€ 940,00	€ 500,00
25	50	25 x 55	119	20 DP + 1 DP	5	15 / 30	18.000 / 24.000	€ 1.026,00	€ 550,00
25	54	25 x 55	124	22 DP + 1 DP	5	15 / 30	18.000 / 24.000	€ 1.115,00	€ 600,00
25	59	25 x 55	129	24 DP + 1 DP	5	15 / 30	18.000 / 24.000	€ 1.202,00	€ 660,00
25	64	25 x 55	134	26 DP + 1 DP	5	15 / 30	18.000 / 24.000	€ 1.290,00	€ 710,00



**PTNC3**

**Frese per pantografo elicoidali ad alto rendimento mod. TURBO**  
**Z=3+3+1 DP - elica negativa**



**High performance spiral router cutters mod. TURBO**  
**Z=3+3+1 DP - negative twist**

**Hochleistungs-Spiraloberfräser mod. TURBO**  
**Z=3+3+1 DP - negativer Drall**

**Fraises à défoncer hélicoïdales à haute vitesse mod. TURBO**  
**Z=3+3+1 DP - hélice négative**

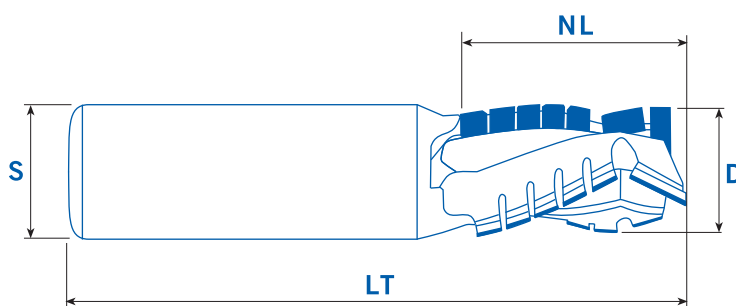
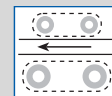
**Fresas para CN helicoidales de alto rendimiento mod. TURBO**  
**Z=3+3+1 DP - hélice negativa**

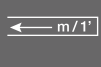

D	NL	S	LT	PL	H	 m/1'	 n/max	Prezzo Price Preis Prix Precio	Affilatura Sharpening Erodieren Affûtage Afilado
20	25	20 x 50	88	8 DP	4,5	20 / 30	18.000 / 24.000	€ 355,00	€ 175,00
20	30	20 x 50	92	11 DP	4,5	20 / 30	18.000 / 24.000	€ 410,00	€ 225,00
22	35	20 x 50	97	14 DP	4,5	20 / 30	18.000 / 24.000	€ 460,00	€ 255,00
22	40	20 x 50	102	17 DP	4,5	20 / 30	18.000 / 24.000	€ 510,00	€ 300,00
25	25	25 x 55	100	8 DP	4,5	20 / 30	18.000 / 24.000	€ 355,00	€ 175,00
25	30	25 x 55	100	11 DP	4,5	20 / 30	18.000 / 24.000	€ 410,00	€ 225,00
25	35	25 x 55	105	14 DP	4,5	20 / 30	18.000 / 24.000	€ 460,00	€ 255,00
25	40	25 x 55	110	17 DP	4,5	20 / 30	18.000 / 24.000	€ 510,00	€ 300,00
25	45	25 x 55	115	20 DP	4,5	20 / 30	18.000 / 24.000	€ 565,00	€ 335,00
25	50	25 x 55	120	23 DP	4,5	20 / 30	18.000 / 24.000	€ 615,00	€ 375,00
25	55	25 x 55	125	26 DP	4,5	20 / 30	18.000 / 24.000	€ 665,00	€ 410,00
25	62	25 x 55	130	29 DP	4,5	20 / 30	18.000 / 24.000	€ 720,00	€ 440,00
25	67	25 x 55	135	32 DP	4,5	20 / 30	18.000 / 24.000	€ 770,00	€ 480,00



**PTPC3**

**Frese per pantografo elicoidali ad alto rendimento mod. TURBO**  
**Z=3+3+1 DP - elica positiva**

**High performance spiral router cutters mod. TURBO**  
**Z=3+3+1 DP - positive twist**

**Hochleistungs-Spiraloberfräser mod. TURBO**  
**Z=3+3+1 DP - positiver Drall**

**Fraises à défoncer hélicoïdales à haute vitesse mod. TURBO**  
**Z=3+3+1 DP - hélice positive**

**Fresas para CN helicoidales de alto rendimiento mod. TURBO**  
**Z=3+3+1 DP - hélice positiva**

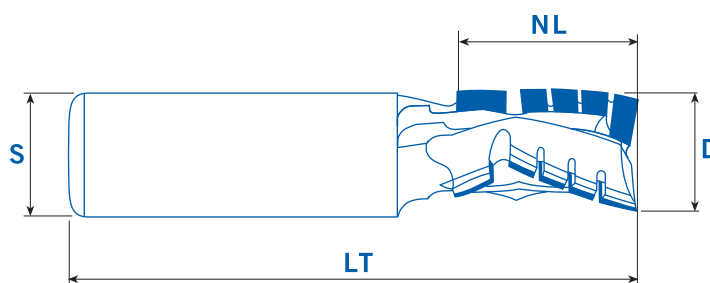
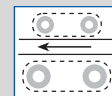

D	NL	S	LT	PL	H	← m/1' →	 n/max	Prezzo Price Preis Prix Precio	Affilatura Sharpening Erodieren Affûtage Afilado
20	25	20 x 50	85	8 DP	4,5	20 / 30	18.000 / 24.000	€ 240,00	€ 145,00
20	30	20 x 50	90	11 DP	4,5	20 / 30	18.000 / 24.000	€ 330,00	€ 195,00
22	35	20 x 50	95	14 DP	4,5	20 / 30	18.000 / 24.000	€ 420,00	€ 255,00
22	40	20 x 50	100	17 DP	4,5	20 / 30	18.000 / 24.000	€ 510,00	€ 300,00
25	25	25 x 55	90	8 DP	4,5	20 / 30	18.000 / 24.000	€ 240,00	€ 145,00
25	30	25 x 55	95	11 DP	4,5	20 / 30	18.000 / 24.000	€ 330,00	€ 195,00
25	35	25 x 55	100	14 DP	4,5	20 / 30	18.000 / 24.000	€ 420,00	€ 255,00
25	40	25 x 55	105	17 DP	4,5	20 / 30	18.000 / 24.000	€ 510,00	€ 300,00
25	45	25 x 55	110	20 DP	4,5	20 / 30	18.000 / 24.000	€ 565,00	€ 335,00
25	50	25 x 55	115	23 DP	4,5	20 / 30	18.000 / 24.000	€ 615,00	€ 375,00
25	55	25 x 55	120	26 DP	4,5	20 / 30	18.000 / 24.000	€ 665,00	€ 410,00
25	61	25 x 55	126	29 DP	4,5	20 / 30	18.000 / 24.000	€ 720,00	€ 440,00
25	66	25 x 55	131	31 DP	4,5	20 / 30	18.000 / 24.000	€ 770,00	€ 480,00



**PTNS2**

Frese per pantografo elicoidali ad alto rendimento mod. TURBO-S  
Z=2+2+1 DP - elica negativa spezzata

High performance spiral router cutters mod. TURBO-S  
Z=2+2+1 DP - negative broken twist

Hochleistungs-Spiraloberfräser mod. TURBO-S  
Z=2+2+1 DP - negativer gebrochen Drall

Fraises à défoncer hélicoïdales à haute vitesse mod. TURBO-S  
Z=2+2+1 DP - hélice négative brisée

Fresas para CN helicoidales de alto rendimiento mod. TURBO-S  
Z=2+2+1 DP - hélice negativa rota

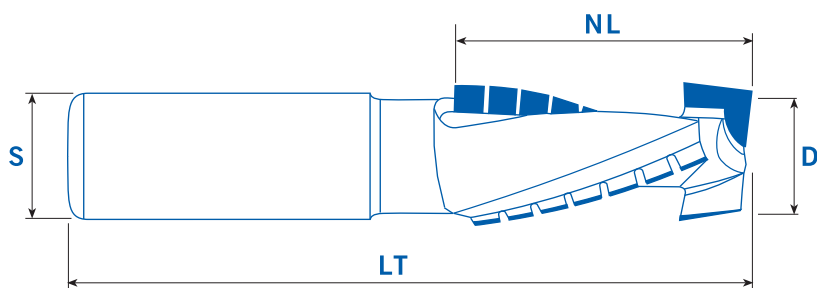
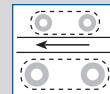

D	NL	S	LT	PL	H	← m/1'	 n/max	Prezzo Price Preis Prix Precio	Affilatura Sharpening Erodieren Affûtage Afilado
20	25	20 x 50	88	9 DP	4,5	12 / 20	18.000 / 24.000	€ 310,00	€ 145,00
20	34	20 x 50	97	13 DP	4,5	12 / 20	18.000 / 24.000	€ 380,00	€ 210,00
20	45	20 x 50	108	17 DP	4,5	12 / 20	18.000 / 24.000	€ 450,00	€ 255,00
22	45	20 x 50	108	17 DP	4,5	12 / 20	18.000 / 24.000	€ 450,00	€ 255,00
22	50	20 x 50	114	19 DP	4,5	12 / 20	18.000 / 24.000	€ 485,00	€ 285,00



**PTNS3**

**Frese per pantografo elicoidali ad alto rendimento mod. TURBO-S  
Z=3+3+1 DP - elica negativa spezzata**

**High performance spiral router cutters mod. TURBO-S  
Z=3+3+1 DP - negative broken twist**

**Hochleistungs-Spiraloberfräser mod. TURBO-S  
Z=3+3+1 DP - negativer gebrochen Drall**

**Fraises à défoncer hélicoïdales à haute vitesse mod. TURBO-S  
Z=3+3+1 DP - hélice négative Brisée**

**Fresas para CN helicoidales de alto rendimiento mod. TURBO-S  
Z=3+3+1 DP - hélice negativa rota**

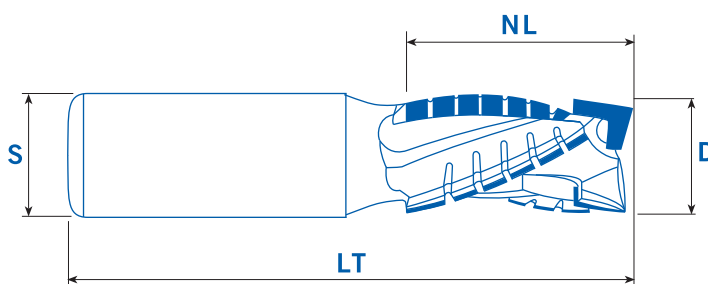
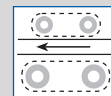

D	NL	S	LT	PL	H	$\leftarrow \frac{m}{1'}$	$\ominus \frac{n}{\max} \oplus$	Prezzo Price Preis Prix Precio	Affilatura Sharpening Erodieren Affûtage Afilado
22	27	20 x 50	87	14 DP	4,5	30	18.000 / 24.000	€ 435,00	€ 240,00
22	32	20 x 50	92	17 DP	4,5	30	18.000 / 24.000	€ 490,00	€ 270,00
22	37	20 x 50	97	20 DP	4,5	30	18.000 / 24.000	€ 540,00	€ 315,00
25	27	25 x 55	92	14 DP	4,5	30	18.000 / 24.000	€ 435,00	€ 240,00
25	32	25 x 55	97	17 DP	4,5	30	18.000 / 24.000	€ 490,00	€ 270,00
25	37	25 x 55	102	20 DP	4,5	30	18.000 / 24.000	€ 540,00	€ 315,00
25	42	25 x 55	107	23 DP	4,5	30	18.000 / 24.000	€ 590,00	€ 350,00
25	47	25 x 55	112	26 DP	4,5	30	18.000 / 24.000	€ 645,00	€ 390,00
25	52	25 x 55	117	29 DP	4,5	30	18.000 / 24.000	€ 695,00	€ 425,00
25	57	25 x 55	122	32 DP	4,5	30	18.000 / 24.000	€ 750,00	€ 465,00
25	62	25 x 55	127	35 DP	4,5	30	18.000 / 24.000	€ 800,00	€ 500,00
25	67	25 x 55	132	38 DP	4,5	30	18.000 / 24.000	€ 850,00	€ 540,00



**PTPS3**

**Frese per pantografo elicoidali ad alto rendimento mod. TURBO-S  
Z=3+3+1 DP - elica positiva spezzata**

**High performance spiral router cutters mod. TURBO-S  
Z=3+3+1 DP - positive broken twist**

**Hochleistungs-Spiraloberfräser mod. TURBO-S  
Z=3+3+1 DP - positiver gebrochen Drill**

**Fraises à défoncer hélicoïdales à haute vitesse mod. TURBO-S  
Z=3+3+1 DP - hélice positive brisée**

**Fresas para CN helicoidales de alto rendimiento mod. TURBO-S  
Z=3+3+1 DP - hélice positiva rota**

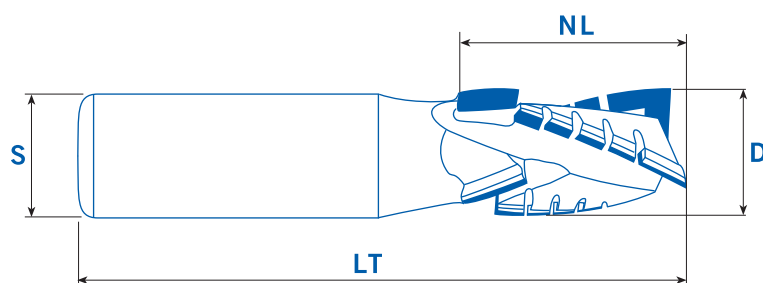
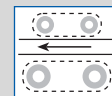

D	NL	S	LT	PL	H	 m/1'	 n/max	Prezzo Price Preis Prix Precio	Affilatura Sharpening Erodieren Affûtage Afilado
22	25	20 x 50	86	9 DP	4,5	15 / 30	18.000 - 24.000	€ 395,00	€ 165,00
22	30	20 x 50	91	12 DP	4,5	15 / 30	18.000 - 24.000	€ 445,00	€ 210,00
22	35	20 x 50	96	15 DP	4,5	15 / 30	18.000 - 24.000	€ 500,00	€ 240,00
22	40	20 x 50	101	18 DP	4,5	15 / 30	18.000 - 24.000	€ 550,00	€ 285,00
25	25	25 x 55	91	9 DP	4,5	15 / 30	18.000 - 24.000	€ 395,00	€ 165,00
25	30	25 x 55	96	12 DP	4,5	15 / 30	18.000 - 24.000	€ 445,00	€ 210,00
25	35	25 x 55	101	15 DP	4,5	15 / 30	18.000 - 24.000	€ 500,00	€ 240,00
25	40	25 x 55	106	18 DP	4,5	15 / 30	18.000 - 24.000	€ 550,00	€ 285,00
25	45	25 x 55	111	21 DP	4,5	15 / 30	18.000 - 24.000	€ 600,00	€ 330,00
25	50	25 x 55	116	24 DP	4,5	15 / 30	18.000 - 24.000	€ 660,00	€ 365,00
25	55	25 x 55	121	27 DP	4,5	15 / 30	18.000 - 24.000	€ 705,00	€ 405,00
25	62	25 x 55	126	30 DP	4,5	15 / 30	18.000 - 24.000	€ 755,00	€ 440,00
25	67	25 x 55	131	33 DP	4,5	15 / 30	18.000 - 24.000	€ 810,00	€ 480,00





Frese per pantografo ad alto rendimento mod. RICCIO  
Z=2+2/2+2+1 DP - doppia rotazione

High performance router cutters mod. RICCIO  
Z=2+2/2+2+1 DP - double rotation

HochleistungsOberfräser mod. RICCIO  
Z=2+2/2+2+1 DP - Doppeldrehrichtung

Fraises à défoncer à haute vitesse mod. RICCIO  
Z=2+2/2+2+1 DP - double rotation

Fresas para CN de alto rendimiento mod. RICCIO  
Z=2+2/2+2+1 DP - doble rotación

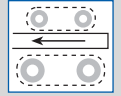

**PDRR2**

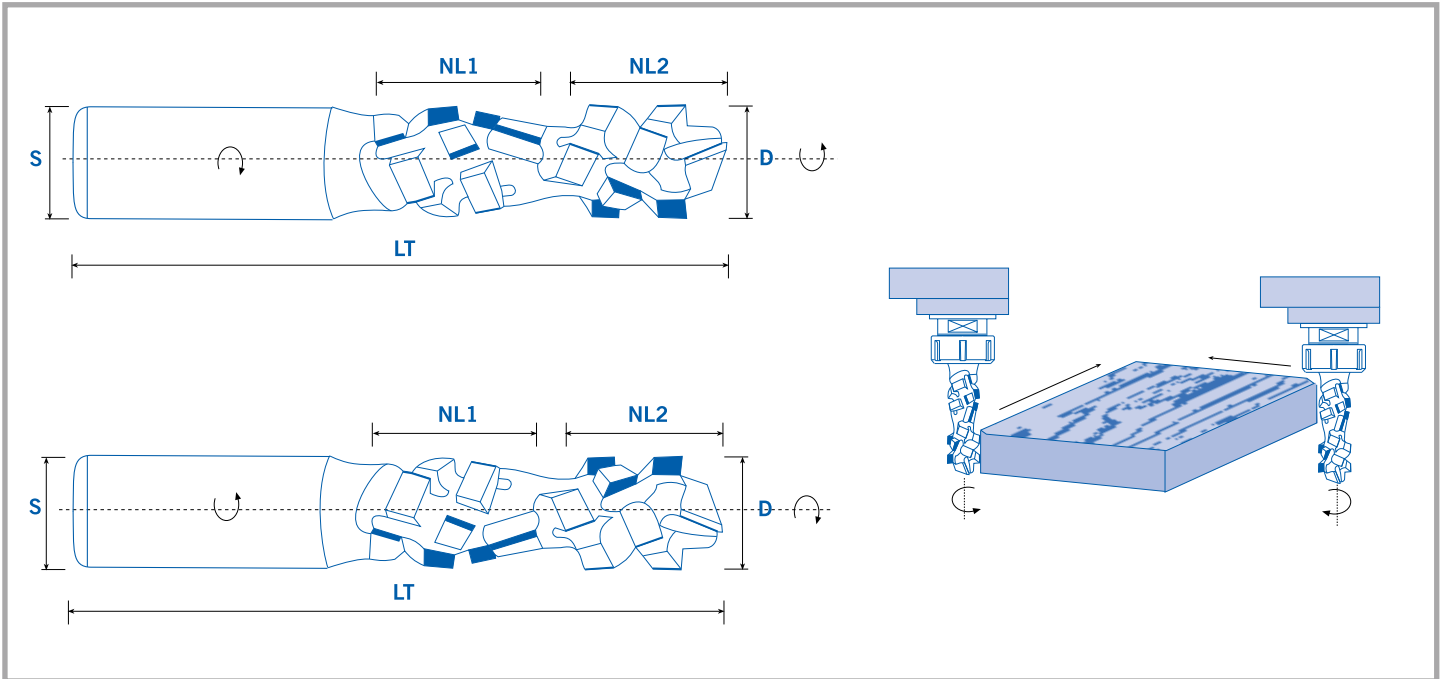

D	NL1/ NL2	S	LT	PL	H	$\leftarrow \text{m/1}^{\circ}$	$\ominus \text{n/max} \oplus$	Prezzo Price Preis Prix Precio	Affilatura Sharpening Erodieren Affûtage Afilado
22	25 + 25	25 x 55	120	6DP/ 6DP/4DP+1DP	4,5	30	18.000/24.000	€ 570,00	€ 255,00
22	30 + 30	25 x 55	130	8DP/ 8DP/4DP+1DP	4,5	30	18.000/24.000	€ 660,00	€ 315,00
22	35 + 35	25 x 55	140	10DP/10DP/4DP+1DP	4,5	30	18.000/24.000	€ 760,00	€ 365,00
22	40 + 40	25 x 55	150	12DP/12DP/4DP+1DP	4,5	30	18.000/24.000	€ 850,00	€ 410,00
30	45 + 45	25 x 55	160	14DP/14DP/4DP+1DP	4,5	30	18.000/24.000	€ 950,00	€ 460,00
30	50 + 50	25 x 55	170	16DP/16DP/4DP+1DP	4,5	30	18.000/24.000	€ 1.035,00	€ 500,00
30	55 + 55	25 x 55	180	18DP/18DP/4DP+1DP	4,5	30	18.000/24.000	€ 1.130,00	€ 560,00

Senso di rotazione su richiesta.  
Direction of rotation upon request.  
Drehrichtung nach Anfrage.  
Sens de rotation suivant demande.  
Sentido de rotación sobre pedido.



Frese per pantografo ad alto rendimento mod. RICCIO  
Z=3+3/3+3+1 DP - doppia rotazione

High performance router cutters mod. RICCIO  
Z=3+3/3+3+1 DP - double rotation

HochleistungsOberfräser mod. RICCIO  
Z=3+3/3+3+1 DP - Doppeldrehrichtung

Fraises à défoncer à haute vitesse mod. RICCIO  
Z=3+3/3+3+1 DP - double rotation

Fresas para CN de alto rendimiento mod. RICCIO  
Z=3+3/3+3+1 DP - doble rotación

**PDRR3**

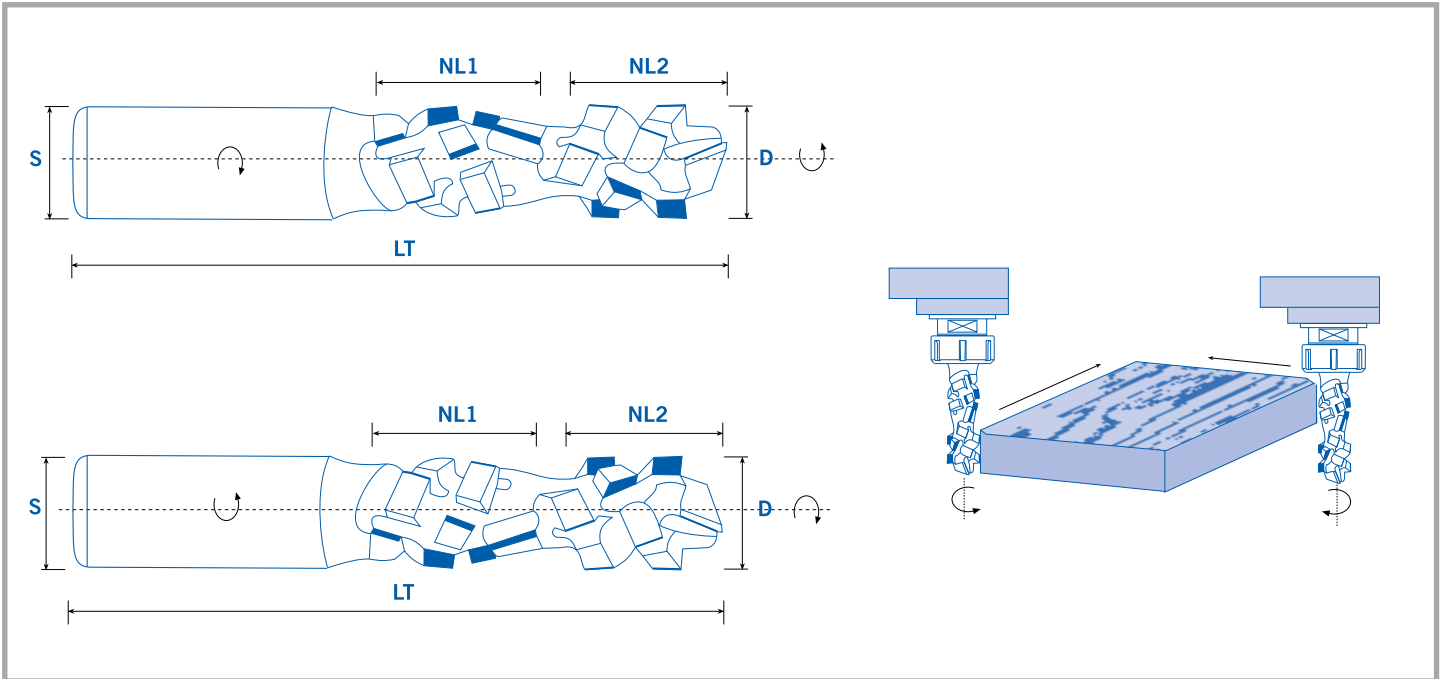
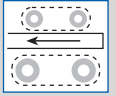

D	NL1/ NL2	S	LT	PL	H	$\leftarrow$ m/1'	 n/max	Prezzo Price Preis Prix Precio	Affilatura Sharpening Erodieren Affûtage Afilado
25	25 + 25	25 x 55	120	9DP/ 9DP/6DP+1DP	4,5	30	18.000/24.000	€ 790,00	€ 365,00
25	30 + 30	25 x 55	130	12DP/12DP/6DP+1DP	4,5	30	18.000/24.000	€ 930,00	€ 440,00
25	35 + 35	25 x 55	140	15DP/15DP/6DP+1DP	4,5	30	18.000/24.000	€ 1.070,00	€ 515,00
25	40 + 40	25 x 55	150	18DP/18DP/6DP+1DP	4,5	30	18.000/24.000	€ 1.210,00	€ 595,00
30	45 + 45	25 x 55	160	21DP/21DP/6DP+1DP	4,5	30	18.000/24.000	€ 1.350,00	€ 610,00
30	50 + 50	25 x 55	170	24DP/24DP/6DP+1DP	4,5	30	18.000/24.000	€ 1.500,00	€ 680,00
30	55 + 55	25 x 55	180	27DP/27DP/6DP+1DP	4,5	30	18.000/24.000	€ 1.630,00	€ 750,00

Senso di rotazione su richiesta.  
Direction of rotation upon request.  
Drehrichtung nach Anfrage.  
Sens de rotation suivant demande.  
Sentido de rotación sobre pedido.



**PDRT**

**Frese per pantografo elicoidali ad alto rendimento mod. TURBO  
Z=3+3/3+3+1 DP - doppia rotazione**

**High performance spiral router cutters mod. TURBO  
Z=3+3/3+3+1 DP - double rotation**

**Hochleistungs-Spiraloberfräser mod. TURBO  
Z=3+3/3+3+1 DP - Doppeldrehrichtung**

**Fraises à défoncer hélicoïdales à haute vitesse mod. TURBO  
Z=3+3/3+3+1 DP - double rotation**

**Fresas para CN helicoidales de alto rendimiento mod. TURBO  
Z=3+3/3+3+1 DP - doble rotación**

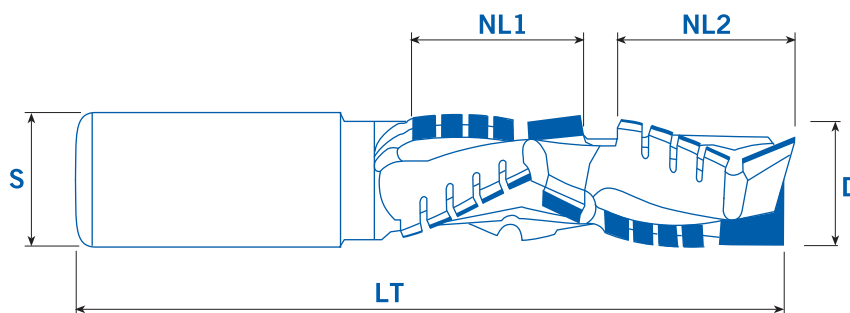
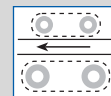

D	NL1/ NL2	S	LT	PL	H			Prezzo Price Preis Prix Precio	Affilatura Sharpening Erodieren Affûtage Afilado
25	25 + 25	25 x 55	124	21 DP	4,5	30	18.000/24.000	€ 750,00	€ 315,00
25	30 + 30	25 x 55	134	27 DP	4,5	30	18.000/24.000	€ 860,00	€ 390,00
25	35 + 35	25 x 55	144	33 DP	4,5	30	18.000/24.000	€ 960,00	€ 465,00
25	40 + 40	25 x 55	154	39 DP	4,5	30	18.000/24.000	€ 1.060,00	€ 540,00
30	45 + 45	25 x 55	164	45 DP	4,5	30	18.000/24.000	€ 1.165,00	€ 585,00
30	50 + 50	25 x 55	174	51 DP	4,5	30	18.000/24.000	€ 1.270,00	€ 660,00
30	55 + 55	25 x 55	184	57 DP	4,5	30	18.000/24.000	€ 1.370,00	€ 730,00

Senso di rotazione su richiesta.  
Direction of rotation upon request.  
Drehrichtung nach Anfrage.  
Sens de rotation suivant demande.  
Sentido de rotación sobre pedido.



Frese per pantografo ad alto rendimento  
Z=2+2/2+2+1 DP doppia rotazione

High performance router cutters  
Z=2+2/2+2+1 DP double rotation

HochleistungsOberfräser  
Z=2+2/2+2+1 DP doppel-drehrichtung

Fraises à défoncer à haute vitesse  
Z=2+2/2+2+1 DP double rotation

Fresas para CN de alto rendimiento  
Z=2+2/2+2+1 DP doble rotación

**PDR45°**

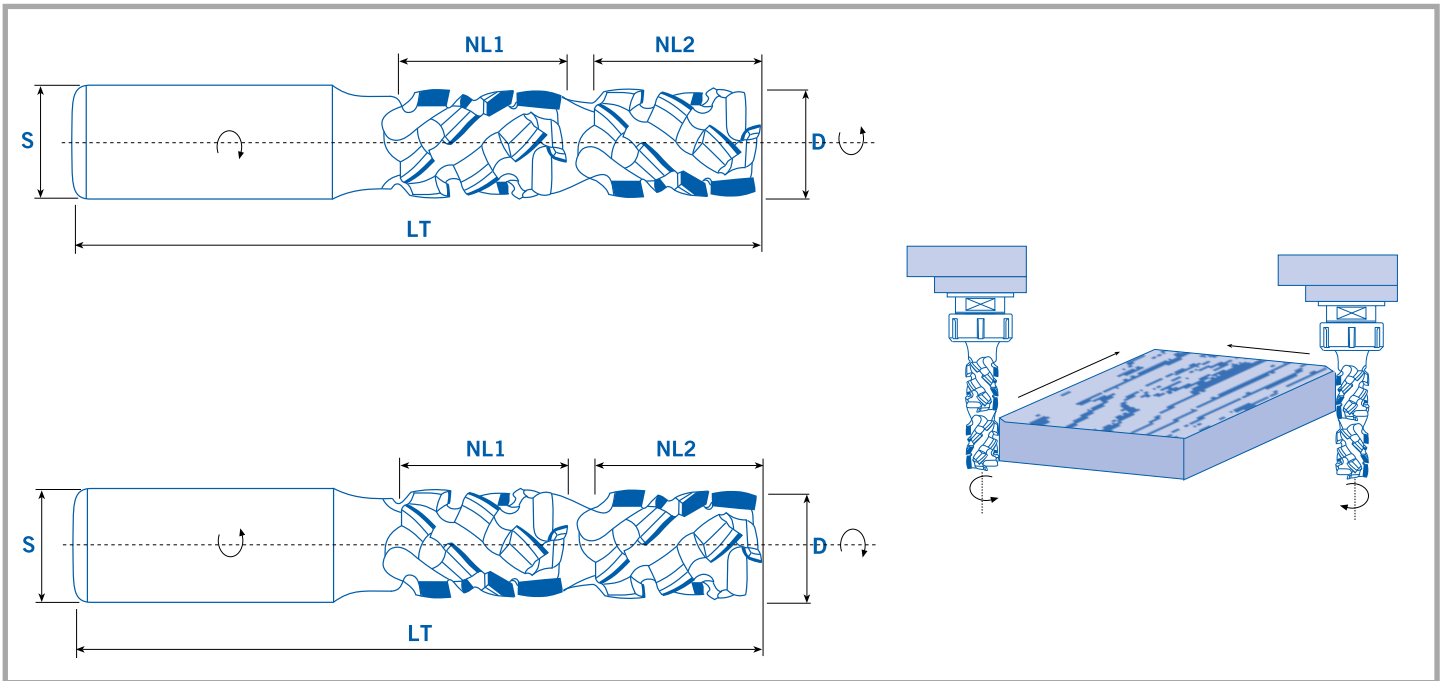
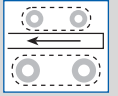

D	NL1/NL2	S	LT	PL	H	 n/max	Prezzo Price Preis Prix Precio	Affilatura Sharpening Erodieren Affûtage Afilado
25	20 + 20	25 x 55	105	17 PL	5	18.000/24.000	€ 670,00	€ 290,00
25	25 + 25	25 x 55	115	21 PL	5	18.000/24.000	€ 790,00	€ 350,00
25	30 + 30	25 x 55	125	25 PL	5	18.000/24.000	€ 915,00	€ 425,00
25	35 + 35	25 x 55	135	29 PL	5	18.000/24.000	€ 1.035,00	€ 490,00
25	40 + 40	25 x 55	145	33 PL	5	18.000/24.000	€ 1.160,00	€ 560,00
30	45 + 45	25 x 55	160	37 PL	5	18.000/24.000	€ 1.280,00	€ 620,00
30	50 + 50	25 x 55	170	41 PL	5	18.000/24.000	€ 1.405,00	€ 690,00
30	55 + 55	25 x 55	180	45 PL	5	18.000/24.000	€ 1.525,00	€ 765,00

Senso di rotazione su richiesta.  
Direction of rotation upon request.  
Drehrichtung nach Anfrage.  
Sens de rotation suivant demande.  
Sentido de rotación sobre pedido.



**Frese per pantografo ad alto rendimento**  
**Z=2+2/2+2+1 DP doppia rotazione**

**High performance router cutters**  
**Z=2+2/2+2+1 DP double rotation**

**HochleistungsOberfräser**  
**Z=2+2/2+2+1 DP doppel-drehrichtung**

**Fraises à défoncer à haute vitesse**  
**Z=2+2/2+2+1 DP double rotation**

**Fresas para CN de alto rendimiento**  
**Z=2+2/2+2+1 DP doble rotación**

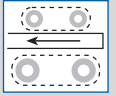

**PDR54°**

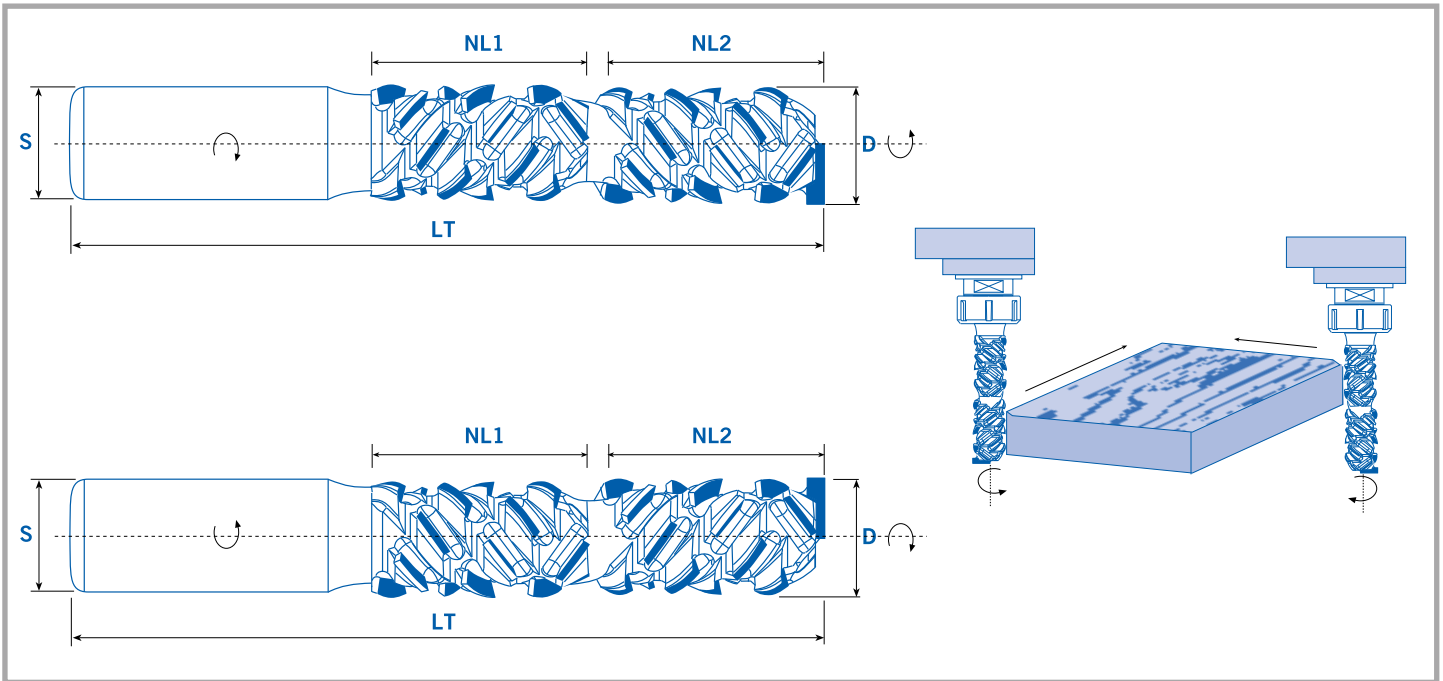

D	NL1/NL2	S	LT	PL	H	 n/max	Prezzo Price Preis Prix Precio	Affilatura Sharpening Erodieren Affûtage Afilado
25	20 + 20	25 x 55	110	16 DP + 1 DP	5	18.000/24.000	€ 850,00	€ 480,00
25	25 + 25	25 x 55	120	20 DP + 1 DP	5	18.000/24.000	€ 1.030,00	€ 580,00
25	30 + 30	25 x 55	130	24 DP + 1 DP	5	18.000/24.000	€ 1.205,00	€ 700,00
25	35 + 35	25 x 55	140	28 DP + 1 DP	5	18.000/24.000	€ 1.380,00	€ 800,00
25	40 + 40	25 x 55	150	32 DP + 1 DP	5	18.000/24.000	€ 1.560,00	€ 900,00
30	45 + 45	25 x 55	160	36 DP + 1 DP	5	18.000/24.000	€ 1.730,00	€ 1.000,00
30	50 + 50	25 x 55	170	40 DP + 1 DP	5	18.000/24.000	€ 1.910,00	€ 1.100,00
30	55 + 55	25 x 55	180	44 DP + 1 DP	5	18.000/24.000	€ 2.090,00	€ 1.200,00

Senso di rotazione su richiesta.  
 Direction of rotation upon request.  
 Drehrichtung nach Anfrage.  
 Sens de rotation suivant demande.  
 Sentido de rotación sobre pedido.



**PND**

**Frese per Nesting  
Z=3+3+1 DP**

**Router cutters for Nesting  
Z=3+3+1 DP**

**Nestingfräser  
Z=3+3+1 DP**

**Fraises pour Nesting  
Z=3+3+1 DP**

**Fresas para Nesting  
Z=3+3+1 DP**

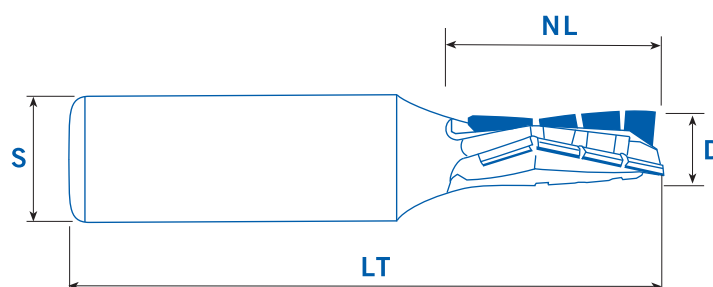
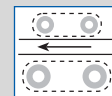

D	NL	S	LT	PL	H	$\leftarrow m/1'$	$\ominus n/max \oplus$	Prezzo Price Preis Prix Precio	Affilatura Sharpening Erodieren Affûtage Afilado
12	21	12 x 50	75	9 DP	3,0	15 / 20	18.000/24.000	€ 530,00	€ 180,00
12	25	12 x 50	81	12 DP	3,0	13 / 18	18.000/24.000	€ 580,00	€ 210,00
12	30	12 x 50	90	12 DP	3,0	10 / 15	18.000/24.000	€ 660,00	€ 225,00
14	25	16 x 50	81	12 DP	3,0	13 / 18	18.000/24.000	€ 660,00	€ 210,00
14	30	16 x 50	90	12 DP	3,0	10 / 15	18.000/24.000	€ 715,00	€ 225,00
14	35	16 x 50	95	14 DP	3,0	8 / 12	18.000/24.000	€ 790,00	€ 240,00
14	41	16 x 50	101	17 DP	3,0	5 / 10	18.000/24.000	€ 870,00	€ 275,00

Corpo in metallo pesante.  
Heavy metal body.  
Grundkörper aus Schwermetall.  
Corps en acier spécifique.  
Cuerpo en metal pesado.



Frese per Nesting  
Z=2+2+1 DP

Router cutters for Nesting  
Z=2+2+1 DP

Nestingfräser  
Z=2+2+1 DP

Fraises pour Nesting  
Z=2+2+1 DP

Fresas para Nesting  
Z=2+2+1 DP

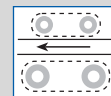

**PND35°**

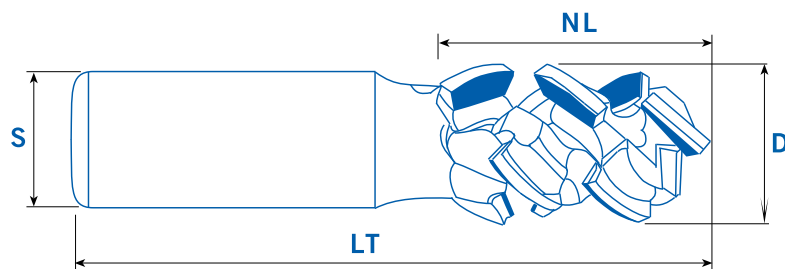

D	NL	S	LT	PL	H			Prezzo Price Preis Prix Precio	Affilatura Sharpening Erodieren Affûtage Afilado
12	21	12 x 45	75	10 DP	3,0	25	18.000 / 24.000	€ 530,00	€ 180,00
12	25	12 x 45	80	12 DP	3,0	25	18.000 / 24.000	€ 580,00	€ 210,00
12	29	12 x 45	84	14 DP	3,0	25	18.000 / 24.000	€ 660,00	€ 225,00
14	25	16 x 45	75	12 DP	3,0	25	18.000 / 24.000	€ 580,00	€ 210,00
14	29	16 x 45	80	14 DP	3,0	25	18.000 / 24.000	€ 660,00	€ 225,00
14	34	16 x 45	85	16 DP	3,0	25	18.000 / 24.000	€ 790,00	€ 240,00
14	38	16 x 45	89	18 DP	3,0	25	18.000 / 24.000	€ 870,00	€ 275,00

Corpo in acciaio speciale.  
Special steel body.  
Grundkörper aus Sonderstahl.  
Corps en acier special.  
Cuerpo en metal especial.



**PNR**

**Frese a raggio per Nesting  
Z=2**

**Router cutters with radius for Nesting  
Z=2**

**Radius-Nestingfräser  
Z=2**

**Fraises profilées pour Nesting  
Z=2**

**Fresas de perfil para Nesting  
Z=2**

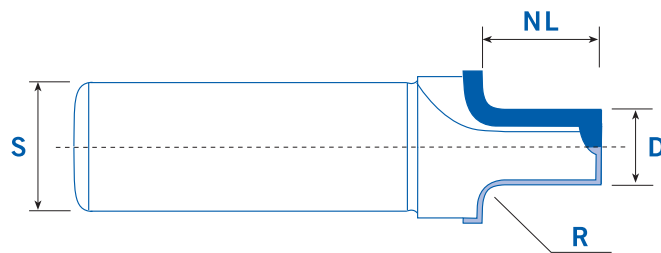
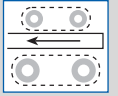

D	NL	R	S	Z	H	 m/1'	 n/max	Prezzo Price Preis Prix Precio	Affilatura Sharpening Erodieren Affûtage Afilado
12	18,3	1	20 x 50	2	3,0	20	18.000 / 24.000	€ 450,00	€ 180,00
12	18,3	2	20 x 50	2	3,0	20	18.000 / 24.000	€ 450,00	€ 180,00
12	18,3	3	20 x 50	2	3,0	20	18.000 / 24.000	€ 450,00	€ 180,00
12	18,6	4	20 x 50	2	3,0	20	18.000 / 24.000	€ 500,00	€ 225,00
12	18,6	5	20 x 50	2	3,0	20	18.000 / 24.000	€ 530,00	€ 225,00





## Frese a finire ad alta velocità

High speed router cutters for finishing

Hochleistungs-Fügefräser für sehr hohe Vorschübe

Fraises de finition à haute vitesse pour façonnage

Fresas de acabado alta velocidad

**PFN30°**

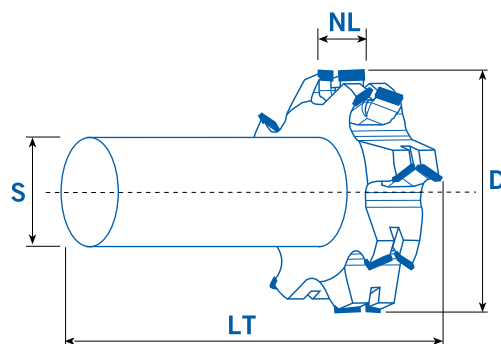
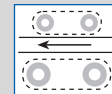

D	NL	S	LT	PL	Z		H			Prezzo Price Preis Prix Precio	Affilatura Sharpening Erodieren Affûtage Afilado
50 - 60	28	20 - 25			3 + 3	30°	5	20 / 35	12.000 / 18.000	€ 580,00	€ 210,00
50 - 60	28	20 - 25			4 + 4	30°	5	20 / 35	12.000 / 18.000	€ 710,00	€ 290,00
50 - 60	35	20 - 25			3 + 3	30°	5	20 / 35	12.000 / 18.000	€ 710,00	€ 260,00
50 - 60	35	20 - 25			4 + 4	30°	5	20 / 35	12.000 / 18.000	€ 900,00	€ 340,00
50 - 60	43	20 - 25			3 + 3	30°	5	20 / 35	12.000 / 18.000	€ 860,00	€ 290,00
50 - 60	43	20 - 25			4 + 4	30°	5	20 / 35	12.000 / 18.000	€ 1.100,00	€ 380,00
50 - 60	48	20 - 25			3 + 3	30°	5	20 / 35	12.000 / 18.000	€ 915,00	€ 315,00
50 - 60	48	20 - 25			4 + 4	30°	5	20 / 35	12.000 / 18.000	€ 1.180,00	€ 420,00
50 - 60	56	20 - 25			3 + 3	30°	5	20 / 35	12.000 / 18.000	€ 1.080,00	€ 380,00
50 - 60	56	20 - 25			4 + 4	30°	5	20 / 35	12.000 / 18.000	€ 1.380,00	€ 500,00
50 - 60	63	20 - 25			3 + 3	30°	5	20 / 35	12.000 / 18.000	€ 1.230,00	€ 400,00
50 - 60	63	20 - 25			4 + 4	30°	5	20 / 35	12.000 / 18.000	€ 1.600,00	€ 535,00



## Frese a finire ad alta velocità

High speed router cutters for finishing

Hochleistungs-Fügefräser für sehr hohe Vorschübe

Fraises de finition à haute vitesse pour façonnage

Fresas de acabado alta velocidad

**PFN45°**

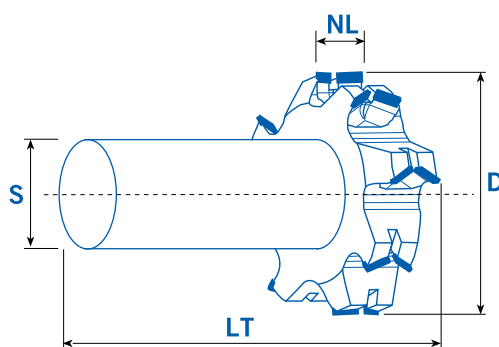
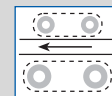

D	NL	S	LT	PL	Z	∠	H	← m/1'	 n/max	Prezzo Price Preis Prix Precio	Affilatura Sharpening Erodieren Affûtage Afilado
50 - 60	28	20 - 25			3 + 3	45°	5	20 / 35	12.000 / 18.000	€ 640,00	€ 285,00
50 - 60	28	20 - 25			4 + 4	45°	5	20 / 35	12.000 / 18.000	€ 810,00	€ 370,00
50 - 60	35	20 - 25			3 + 3	45°	5	20 / 35	12.000 / 18.000	€ 810,00	€ 370,00
50 - 60	35	20 - 25			4 + 4	45°	5	20 / 35	12.000 / 18.000	€ 1.030,00	€ 430,00
50 - 60	43	20 - 25			3 + 3	45°	5	20 / 35	12.000 / 18.000	€ 980,00	€ 410,00
50 - 60	43	20 - 25			4 + 4	45°	5	20 / 35	12.000 / 18.000	€ 1.260,00	€ 495,00
50 - 60	48	20 - 25			3 + 3	45°	5	20 / 35	12.000 / 18.000	€ 1.050,00	€ 460,00
50 - 60	48	20 - 25			4 + 4	45°	5	20 / 35	12.000 / 18.000	€ 1.350,00	€ 545,00
50 - 60	56	20 - 25			3 + 3	45°	5	20 / 35	12.000 / 18.000	€ 1.220,00	€ 480,00
50 - 60	56	20 - 25			4 + 4	45°	5	20 / 35	12.000 / 18.000	€ 1.580,00	€ 600,00
50 - 60	63	20 - 25			3 + 3	45°	5	20 / 35	12.000 / 18.000	€ 1.400,00	€ 520,00
50 - 60	63	20 - 25			4 + 4	45°	5	20 / 35	12.000 / 18.000	€ 1.820,00	€ 675,00



## Frese a finire ad alta velocità

High speed router cutters for finishing

Hochleistungs-Fügefräser für sehr hohe Vorschübe

Fraises de finition à haute vitesse pour façonnage

Fresas de acabado alta velocidad

**PFN54°**

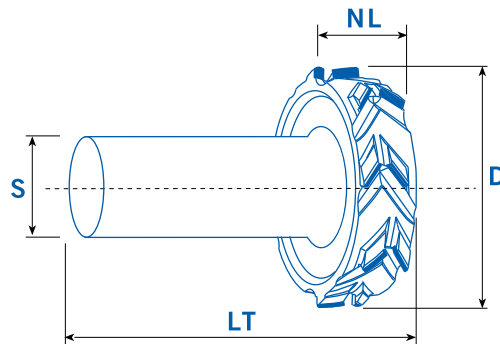
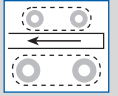

D	NL	S	LT	PL	Z	$\sphericalangle$	H	$\leftarrow$ m/1'	 n/max	Prezzo Price Preis Prix Precio	Affilatura Sharpening Erodieren Affûtage Afilado
50 - 60	28	20 - 25			3 + 3	54°	5	20 / 35	12.000 / 18.000	€ 850,00	€ 280,00
50 - 60	28	20 - 25			4 + 4	54°	5	20 / 35	12.000 / 18.000	€ 1.100,00	€ 380,00
50 - 60	35	20 - 25			3 + 3	54°	5	20 / 35	12.000 / 18.000	€ 1.050,00	€ 350,00
50 - 60	35	20 - 25			4 + 4	54°	5	20 / 35	12.000 / 18.000	€ 1.350,00	€ 470,00
50 - 60	43	20 - 25			3 + 3	54°	5	20 / 35	12.000 / 18.000	€ 1.250,00	€ 420,00
50 - 60	43	20 - 25			4 + 4	54°	5	20 / 35	12.000 / 18.000	€ 1.580,00	€ 560,00
50 - 60	48	20 - 25			3 + 3	54°	5	20 / 35	12.000 / 18.000	€ 1.400,00	€ 490,00
50 - 60	48	20 - 25			4 + 4	54°	5	20 / 35	12.000 / 18.000	€ 1.850,00	€ 660,00
50 - 60	56	20 - 25			3 + 3	54°	5	20 / 35	12.000 / 18.000	€ 1.600,00	€ 565,00
50 - 60	56	20 - 25			4 + 4	54°	5	20 / 35	12.000 / 18.000	€ 2.060,00	€ 750,00
50 - 60	63	20 - 25			3 + 3	54°	5	20 / 35	12.000 / 18.000	€ 1.760,00	€ 630,00
50 - 60	63	20 - 25			4 + 4	54°	5	20 / 35	12.000 / 18.000	€ 2.300,00	€ 860,00



## Punte per spianare ed esecuzione battente

Planing and rebating shank cutters

Plan- und Falzfräser

Mèches à surfacer et usinage feuillure

Fresas de mango para planear y hacer galces

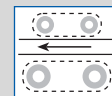

# PSB

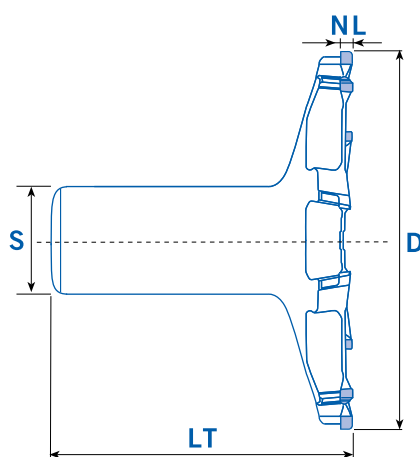

D	NL	S	LT	Z	H	$\leftarrow m/1'$	 n/max	Prezzo Price Preis Prix Precio	Affilatura Sharpening Erodieren Affûtage Afilado
80/100	6	20 - 25	90	6	5	15 - 30	18.000 - 24.000	€ 350,00	€ 170,00
80/100	6	20 - 25	90	8	5	15 - 30	18.000 - 24.000	€ 380,00	€ 230,00

H=Dia 6 mm + 8%  
H=Dia 4 mm -12%



## Frese sagomate per antine

Profile shank cutters for machining cabinet doors

Profilfräser für Möbeltüren Bearbeitung

Fraises profilées pour usinage portes de meubles

Fresas de perfil para trabajar puertas de muebles

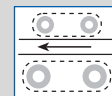

# FRANT-A

### Profilo/Profile/Profil/Profil/Perfil A

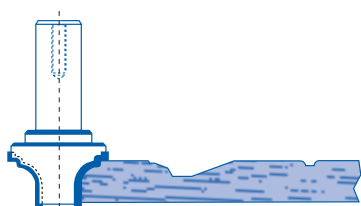
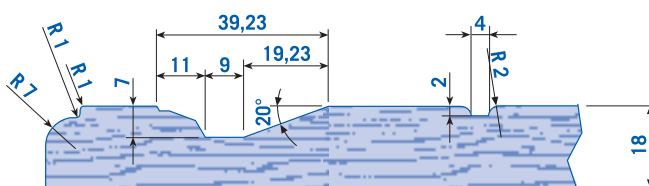

A-001

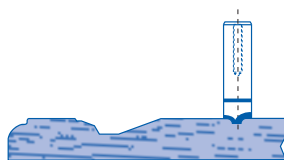

A-002

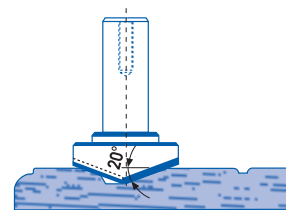

A-003

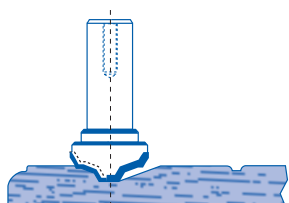

A-004

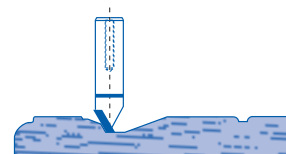

A-005

	D	NL	S	Z	← m / 1'	 n/max	Prezzo Price Preis Prix Precio	Affilatura Sharpening Erodieren Affûtage Afilado
A-001	40	25	20 x 50	2	15 / 20	14.000 / 24.000	€ 875,00	€ 290,00
A-002	20	10	20 x 50	1	7 / 15	14.000 / 24.000	€ 400,00	€ 135,00
A-003	45	15	20 x 50	2	15 / 20	14.000 / 24.000	€ 600,00	€ 220,00
A-004	35	15	20 x 50	2	15 / 20	14.000 / 24.000	€ 500,00	€ 220,00
A-005	10	8	20 x 50	1	7 / 15	14.000 / 24.000	€ 400,00	€ 135,00

Per profili diversi vi preghiamo di consultarci.  
 For different profiles please ask for quotation.  
 Für verschiedene Profile, bitte anfragen.  
 Pour profils différents nous vous prions de nous consulter.  
 Para perfiles diferentes rogamos nos consulten.



## Frese sagomate per antine

Profile shank cutters for machining cabinet doors

Profilfräser für Möbeltüren Bearbeitung

Fraises profilées pour usinage portes de meubles

Fresas de perfil para trabajar puertas de muebles

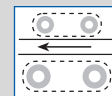

# FRANT-B

### Profilo/Profile/Profil/Profil/Perfil B

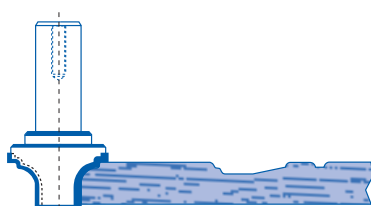
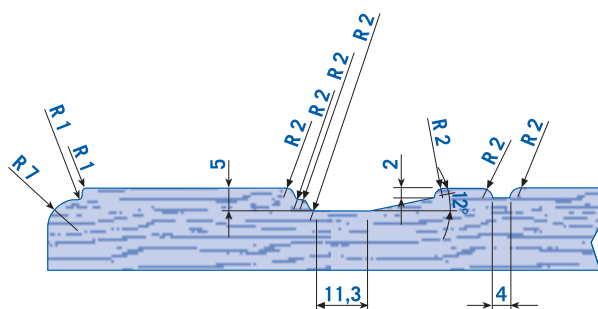

B-001

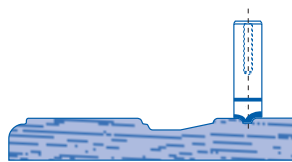

B-002

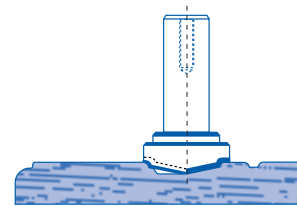

B-003



B-004

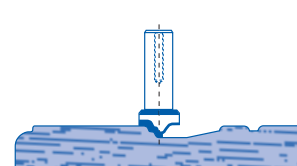

B-005

	D	NL	S	Z	← m/1'	 n/max	Prezzo Price Preis Prix Precio	Affilatura Sharpening Erodieren Affûtage Afilado
B-001	40	25	20 x 50	2	15 / 20	14.000 / 24.000	€ 875,00	€ 290,00
B-002	20	10	20 x 50	1	7 / 15	14.000 / 24.000	€ 400,00	€ 135,00
B-003	45	10	20 x 50	2	15 / 20	14.000 / 24.000	€ 700,00	€ 220,00
B-004	30	15	20 x 50	2	15 / 20	14.000 / 24.000	€ 500,00	€ 200,00
B-005	10	12	20 x 50	1	7 / 15	14.000 / 24.000	€ 450,00	€ 150,00

Per profili diversi vi preghiamo di consultarci.  
 For different profiles please ask for quotation.  
 Für verschiedene Profile, bitte anfragen.  
 Pour profils différents nous vous prions de nous consulter.  
 Para perfiles diferentes rogamos nos consulten.



## Frese sagomate per antine

Profile shank cutters for machining cabinet doors

Profilfräser für Möbeltüren Bearbeitung

Fraises profilées pour usinage portes de meubles

Fresas de perfil para trabajar puertas de muebles

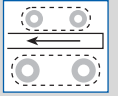

**FRANT-C**

### Profilo/Profile/Profil/Profil/Perfil C

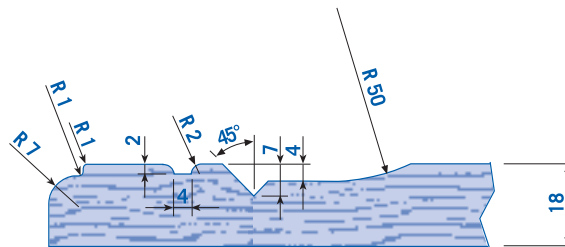

C-001

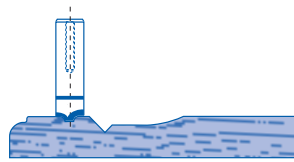

C-002

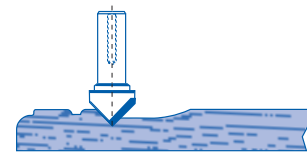

C-003

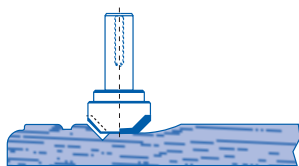

C-004

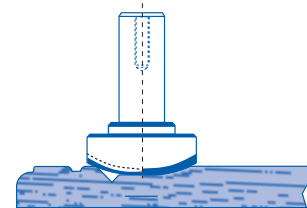

C-005

	D	NL	S	Z	← m/1'	 n/max	Prezzo Price Preis Prix Precio	Affilatura Sharpening Erodieren Affûtage Afilado
C-001	40	25	20 x 50	2	15 / 20	14.000 / 24.000	€ 875,00	€ 290,00
C-002	20	10	20 x 50	1	7 / 15	14.000 / 24.000	€ 400,00	€ 135,00
C-003	15	15	20 x 50	1	7 / 15	14.000 / 24.000	€ 400,00	€ 135,00
C-004	25	15	20 x 50	2	15 / 20	14.000 / 24.000	€ 550,00	€ 200,00
C-005	45	15	20 x 50	2	15 / 20	14.000 / 24.000	€ 630,00	€ 220,00

Per profili diversi vi preghiamo di consultarci.  
 For different profiles please ask for quotation.  
 Für verschiedene Profile, bitte anfragen.  
 Pour profils différents nous vous prions de nous consulter.  
 Para perfiles diferentes rogamos nos consulten.



## Frese sagomate per antine

Profile shank cutters for machining cabinet doors

Profilfräser für Möbeltüren Bearbeitung

Fraises profilées pour usinage portes de meubles

Fresas de perfil para trabajar puertas de muebles

**FRANT-D**

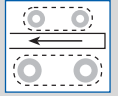

### Profilo/Profile/Profil/Profil/Perfil D

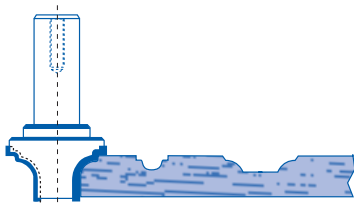
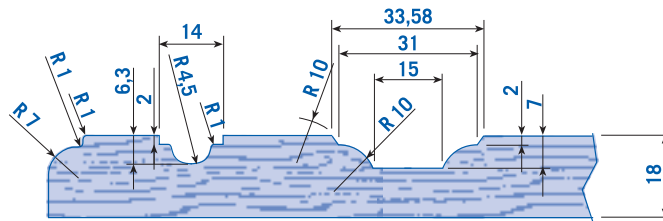

**D-001**

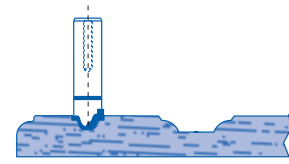

**D-002**

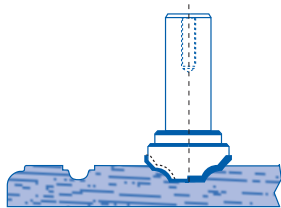

**D-003**

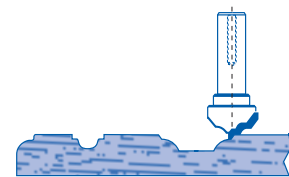

**D-004**

	D	NL	S	Z	← m/1'	 n/max	Prezzo Price Preis Prix Precio	Affilatura Sharpening Erodieren Affûtage Afilado
D-001	40	25	20 x 50	2	15 / 20	14.000 / 24.000	€ 875,00	€ 290,00
D-002	14	10	20 x 50	2	15 / 20	14.000 / 24.000	€ 450,00	€ 150,00
D-003	40	15	20 x 50	2	15 / 20	14.000 / 24.000	€ 550,00	€ 220,00
D-004	25	15	20 x 50	1	7 / 15	14.000 / 24.000	€ 450,00	€ 150,00

Per profili diversi vi preghiamo di consultarci.  
 For different profiles please ask for quotation.  
 Für verschiedene Profile, bitte anfragen.  
 Pour profils différents nous vous prions de nous consulter.  
 Para perfiles diferentes rogamos nos consulten.





**PTS**

**Frese per scanalature  
Z=2+2 - profilo "T"**

**Grooving router cutters  
Z=2+2 - "T" profile**

**Nutoberfräser  
Z=2+2 - "T"-Profil**

**Fraises à rainer à queue cylindrique  
Z=2+2 - profil trapèze**

**Fresas de mango para ranurar  
Z=2+2 - perfil "T"**

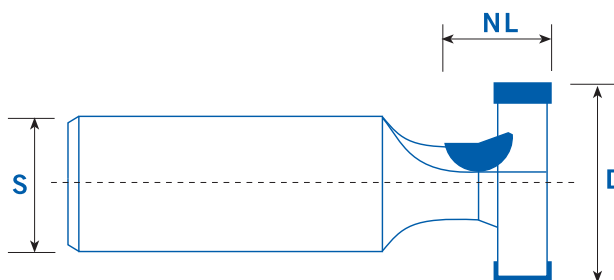
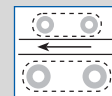

**Esempi di profilo / Profile samples / Profil-Beispiele / Exemples de profil / Ejemplos de perfil**

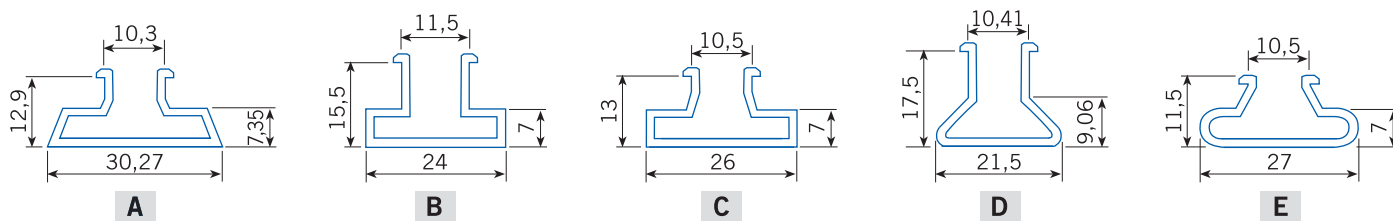

	D	NL	S	Z	← m/1'	 n/max	Prezzo Price Preis Prix Precio	Affilatura Sharpening Erodieren Affûtage Afilado
A	30,3	12,9	20 x 50	2	15 / 20	18.000 / 24.000	€ 425,00	€ 160,00
B	24	15,5	20 x 50	2	15 / 20	18.000 / 24.000	€ 490,00	€ 180,00
C	26	13	20 x 50	2	15 / 20	18.000 / 24.000	€ 450,00	€ 160,00
D	21,5	17,5	20 x 50	2	15 / 20	18.000 / 24.000	€ 400,00	€ 200,00
E	27	11,5	20 x 50	2	15 / 20	18.000 / 24.000	€ 400,00	€ 160,00

Per profili diversi vi preghiamo di consultarci.  
 For different profiles please ask for quotation.  
 Für verschiedene Profile, bitte anfragen.  
 Pour profils différents nous vous prions de nous consulter.  
 Para perfiles diferentes rogamos nos consulten.



PSG

## Frese a profilo per CNC

Profile router cutters

Profiloberfräser

Fraises profilées à queue cylindrique pour CN

Fresas de perfil con mango para CN

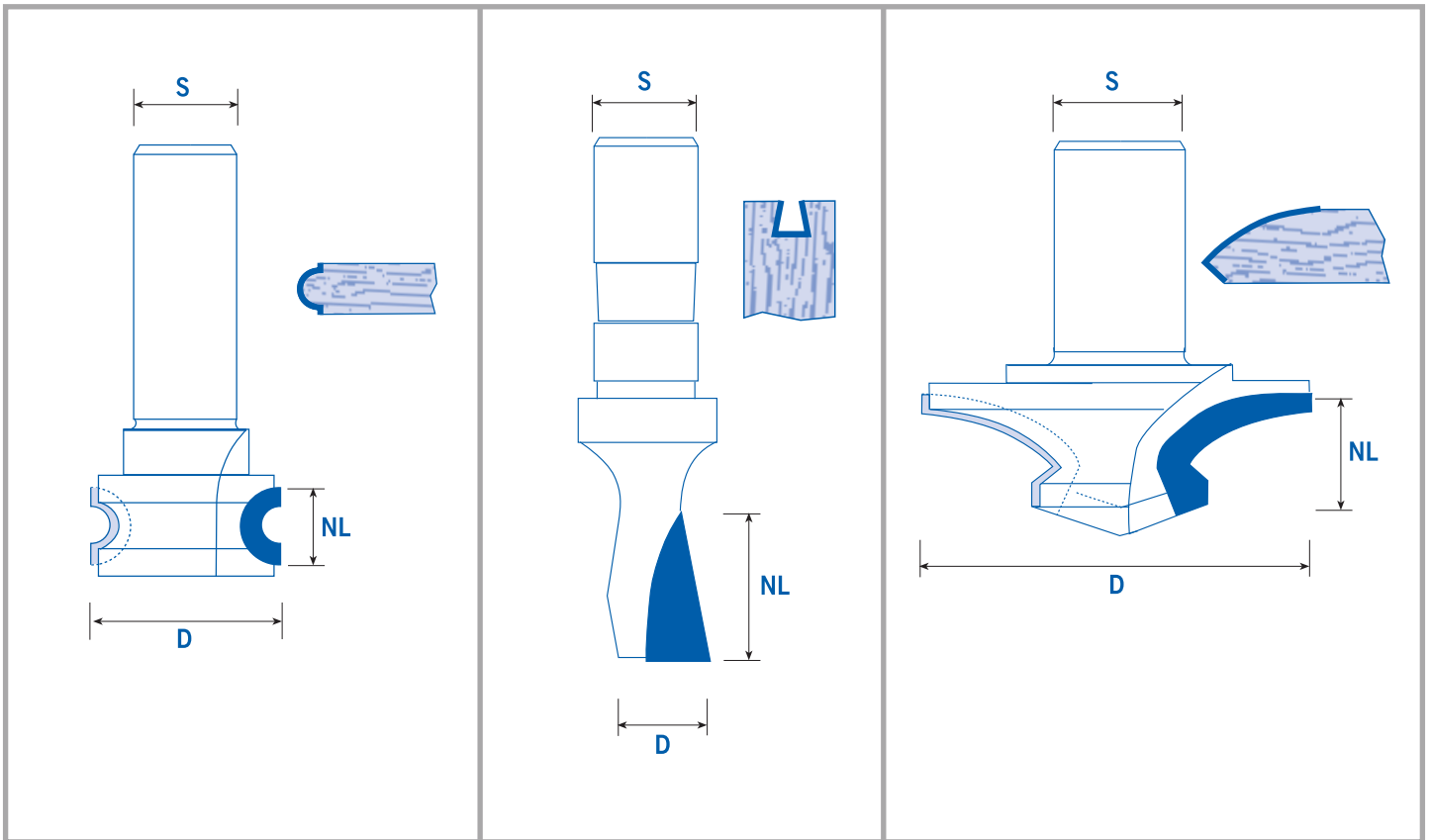
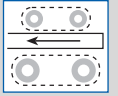

Il prezzo degli utensili dipende dalla loro geometria.  
Per ricevere la nostra offerta vi preghiamo di inviarci un disegno tecnico dell'utensile.

Price depends on tool geometry.  
Please provide a technical drawing of the tool to receive our offer.

Die Preise werden nach der Werkzeugen Geometrie berechnet, um ein Angebot zu bekommen,  
bitten wir um eine technische Zeichnung des Werkzeuges.

Les prix dépendent de la géométrie des outils.  
Pour recevoir notre devis nous vous prions de nous faire parvenir un plan technique de l'outil.

El precio depende de la geometría de las herramientas.  
Para obtener nuestra oferta rogamos nos envíen un dibujo técnico de la herramienta.



Frese per scanalature Z=1

Grooving shank cutters Z=1

Nutoberfräser Z=1

Fraises à rainier à queue cylindrique Z=1

Fresas de mango para ranurar Z=1

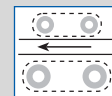

PSC1

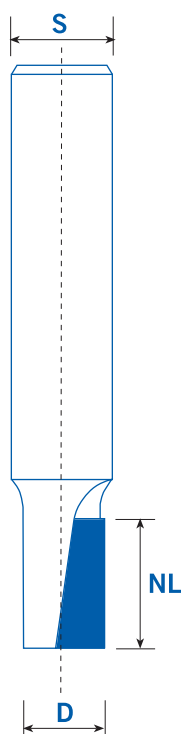

D	NL	S	Z			Prezzo Price Preis Prix Precio	Affilatura Sharpening Erodieren Affûtage Afilado
4	10	6 x 35	1	2 / 4	18.000 / 24.000	€ 210,00	€ 65,00
5	10	6 x 35	1	2 / 4	18.000 / 24.000	€ 205,00	€ 65,00
6	10	6 x 35	1	2 / 4	18.000 / 24.000	€ 207,00	€ 65,00
7	10	8 x 35	1	2 / 4	18.000 / 24.000	€ 220,00	€ 65,00
8	10	8 x 35	1	2 / 4	18.000 / 24.000	€ 230,00	€ 65,00
8	15	8 x 35	1	2 / 4	18.000 / 24.000	€ 250,00	€ 75,00
9	15	10 x 35	1	2 / 4	18.000 / 24.000	€ 250,00	€ 75,00
10	15	10 x 35	1	2 / 4	18.000 / 24.000	€ 250,00	€ 75,00
10	22	10 x 35	1	2 / 4	18.000 / 24.000	€ 300,00	€ 90,00

Corpo in HW.  
 HW body.  
 Grundkörper in HW.  
 Corps HW monobloc.  
 Cuerpo en HW.



Frese per scanalature Z=2+1

Grooving shank cutters Z=2+1

Nutoberfräser Z=2+1

Fraises à rainier à queue cylindrique Z=2+1

Fresas de mango para ranurar Z=2+1

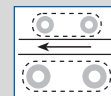

PSC2

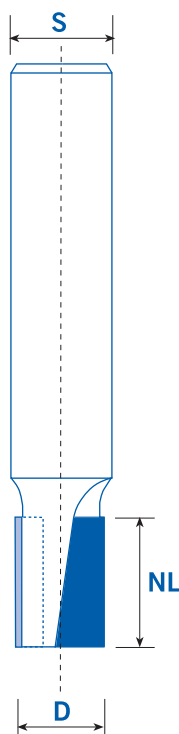

D	NL	S	Z			Prezzo Price Preis Prix Precio	Affilatura Sharpening Erodieren Affûtage Afilado
8	10	8 x 35	2 + 1	3 / 5	12.000 / 18.000	€ 280,00	€ 115,00
8	15	8 x 35	2 + 1	3 / 5	12.000 / 18.000	€ 295,00	€ 125,00
10	15	10 x 35	2 + 1	3 / 5	12.000 / 18.000	€ 305,00	€ 125,00
12	15	12 x 35	2 + 1	3 / 5	12.000 / 18.000	€ 320,00	€ 125,00
12	25	12 x 35	2 + 1	3 / 5	12.000 / 18.000	€ 375,00	€ 150,00

Corpo in HW.  
 HW body.  
 Grundkörper in HW.  
 Corps HW monobloc.  
 Cuerpo en HW.



Frese per scanalature Z=2+1

Grooving shank cutters Z=2+1

Nutoberfräser Z=2+1

Fraises à rainier à queue cylindrique Z=2+1

Fresas de mango para ranurar Z=2+1

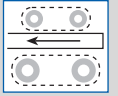

PSC21

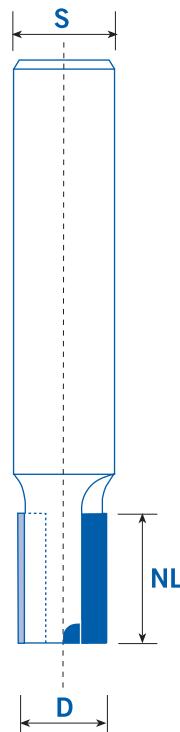

D	NL	S	Z	H	$\leftarrow \text{m/1'}$	$\ominus \text{ n/max } \oplus$	Prezzo Price Preis Prix Precio	Affilatura Sharpening Erodieren Affûtage Afilado
12	25	12 x 40	2 + 1	3,5	3 / 5	24.000	€ 250,00	€ 150,00
14	25	16 x 45	2 + 1	3,5	3 / 5	24.000	€ 250,00	€ 150,00
16	25	16 x 45	2 + 1	4,0	3 / 5	24.000	€ 265,00	€ 160,00
16	34	16 x 45	2 + 1	4,0	3 / 5	24.000	€ 325,00	€ 175,00
18	25	20 x 50	2 + 1	4,0	3 / 5	24.000	€ 265,00	€ 160,00
18	34	20 x 50	2 + 1	4,0	3 / 5	24.000	€ 325,00	€ 190,00
20	25	20 x 50	2 + 1	5,0	3 / 5	24.000	€ 315,00	€ 160,00
20	34	20 x 50	2 + 1	5,0	3 / 5	24.000	€ 385,00	€ 190,00



Punte per cerniere  
Z=2+2 rasanti

Hinge boring bits  
Z=2+2 spurs

Beschlaglochbohrer  
Z=2+2 Vorschneider

Mèches pour charnières  
Z=2+2 traceurs

Brocas para bisagras  
Z=2+2 precortadores

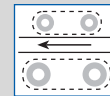

**PCR22**

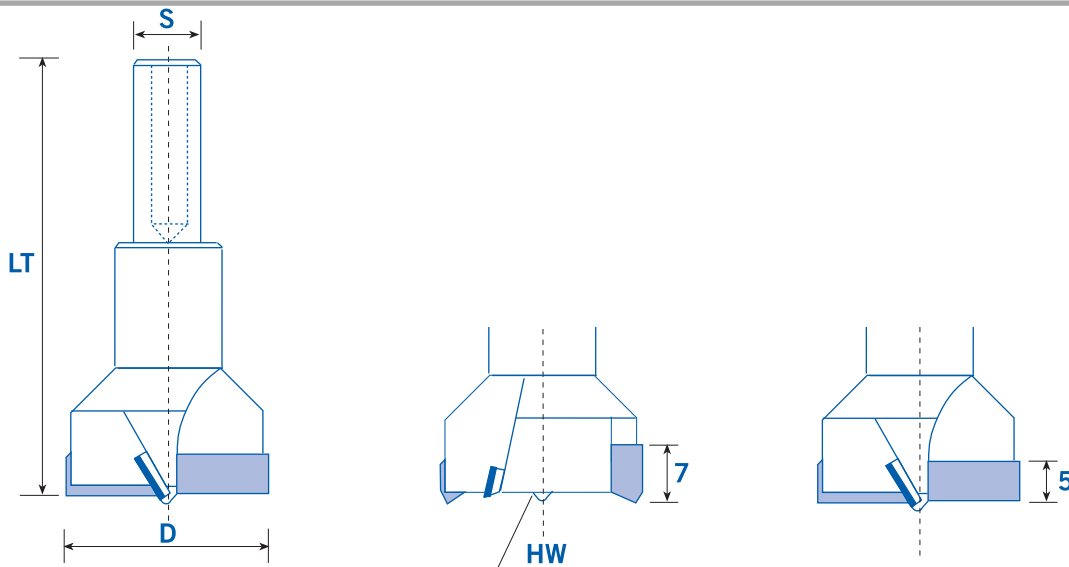

D	LT	S	Z	H	$\leftarrow \text{m/1}^{\circ}$	 n/max	Prezzo Price Preis Prix Precio	Affilatura Sharpening Erodieren Affûtage Afilado
14	57	10 x 30	2 + 2	5	2 / 4	2.800 / 7.000	€ 295,00	€ 130,00
16	57	10 x 30	2 + 2	5	2 / 4	2.800 / 7.000	€ 295,00	€ 130,00
18	57	10 x 30	2 + 2	5	2 / 4	2.800 / 7.000	€ 295,00	€ 130,00
20	57	10 x 30	2 + 2	5	2 / 4	2.800 / 7.000	€ 295,00	€ 130,00
22	57	10 x 30	2 + 2	5	2 / 4	2.800 / 7.000	€ 335,00	€ 130,00
25	57	10 x 30	2 + 2	5	2 / 4	2.800 / 7.000	€ 335,00	€ 130,00
26	57	10 x 30	2 + 2	5	2 / 4	2.800 / 7.000	€ 335,00	€ 130,00
30	57	10 x 30	2 + 2	5	2 / 4	2.800 / 7.000	€ 350,00	€ 130,00
35	57	10 x 30	2 + 2	5	2 / 4	2.800 / 7.000	€ 385,00	€ 130,00
38	57	10 x 30	2 + 2	5	2 / 4	2.800 / 7.000	€ 385,00	€ 130,00
40	57	10 x 30	2 + 2	5	2 / 4	2.800 / 7.000	€ 445,00	€ 130,00
14	70	10 x 30	2 + 2	5	2 / 4	2.800 / 7.000	€ 295,00	€ 130,00
16	70	10 x 30	2 + 2	5	2 / 4	2.800 / 7.000	€ 295,00	€ 130,00
18	70	10 x 30	2 + 2	5	2 / 4	2.800 / 7.000	€ 295,00	€ 130,00
20	70	10 x 30	2 + 2	5	2 / 4	2.800 / 7.000	€ 295,00	€ 130,00
22	70	10 x 30	2 + 2	5	2 / 4	2.800 / 7.000	€ 335,00	€ 130,00
25	70	10 x 30	2 + 2	5	2 / 4	2.800 / 7.000	€ 335,00	€ 130,00
26	70	10 x 30	2 + 2	5	2 / 4	2.800 / 7.000	€ 335,00	€ 130,00
30	70	10 x 30	2 + 2	5	2 / 4	2.800 / 7.000	€ 350,00	€ 130,00
35	70	10 x 30	2 + 2	5	2 / 4	2.800 / 7.000	€ 385,00	€ 130,00
38	70	10 x 30	2 + 2	5	2 / 4	2.800 / 7.000	€ 385,00	€ 130,00
40	70	10 x 30	2 + 2	5	2 / 4	2.800 / 7.000	€ 445,00	€ 130,00

H=Dia 3 mm -12%



Punte per cerniere  
Z=2+4 rasanti

Hinge boring bits  
Z=2+4 spurs

Beschlaglochbohrer  
Z=2+4 Vorschneider

Mèches pour charnières  
Z=2+4 traceurs

Brocas para bisagras  
Z=2+4 precortadores

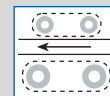

**PCR24**

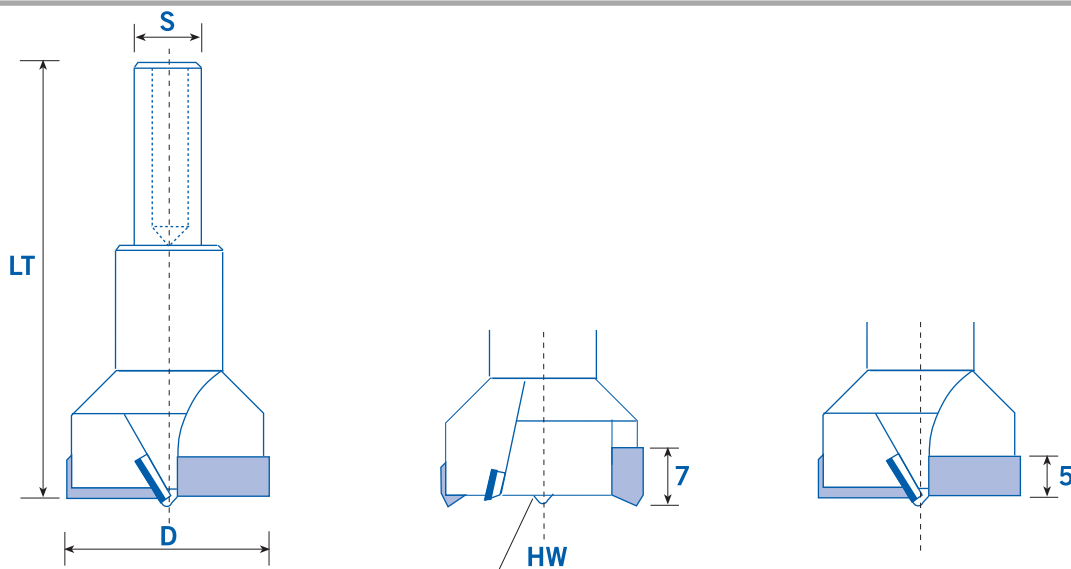

D	NL	S	Z	H			Prezzo Price Preis Prix Precio	Affilatura Sharpening Erodieren Affûtage Afilado
35	57	10 x 30	2 + 4	5	2 / 4	2.800 / 7.000	€ 460,00	€ 170,00
38	57	10 x 30	2 + 4	5	2 / 4	2.800 / 7.000	€ 460,00	€ 170,00
40	57	10 x 30	2 + 4	5	2 / 4	2.800 / 7.000	€ 460,00	€ 170,00
35	70	10 x 30	2 + 4	5	2 / 4	2.800 / 7.000	€ 460,00	€ 170,00
38	70	10 x 30	2 + 4	5	2 / 4	2.800 / 7.000	€ 460,00	€ 170,00
40	70	10 x 30	2 + 4	5	2 / 4	2.800 / 7.000	€ 460,00	€ 170,00

H=Dia 3 mm -12%



Punte per fori passanti Z=1

Through-hole drills Z=1

Durchgangslochbohrer Z=1

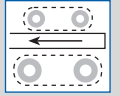

Mèches de perçage pour trous débouchants Z=1

Brocas para agujeros pasantes Z=1

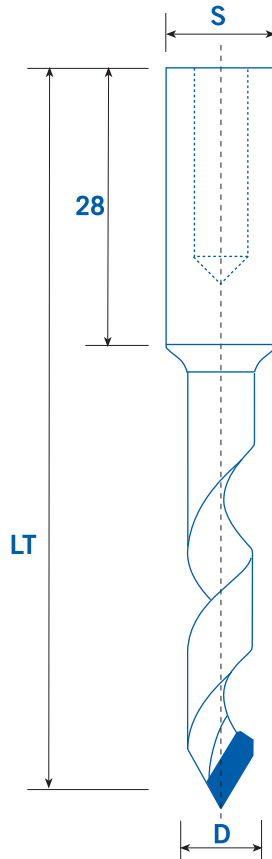

PFP1



D	LT	S	Z	 m/1'	 n/max	Prezzo Price Preis Prix Precio	Affilatura Sharpening Erodieren Affûtage Afilado
5	70	10 x 28	1	2,5 / 4	4.000 / 9.000	€ 195,00	€ 100,00
6	70	10 x 28	1	2,5 / 4	4.000 / 9.000	€ 195,00	€ 100,00
8	70	10 x 28	1	2,5 / 4	4.000 / 9.000	€ 195,00	€ 100,00
10	70	10 x 28	1	2,5 / 4	4.000 / 9.000	€ 195,00	€ 100,00





Punte per fori passanti Z=2

Through-hole drills Z=2

Durchgangslochbohrer Z=2

Mèches de perçage pour trous débouchants Z=2

Brocas para agujeros pasantes Z=2

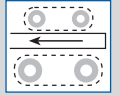

PFP2

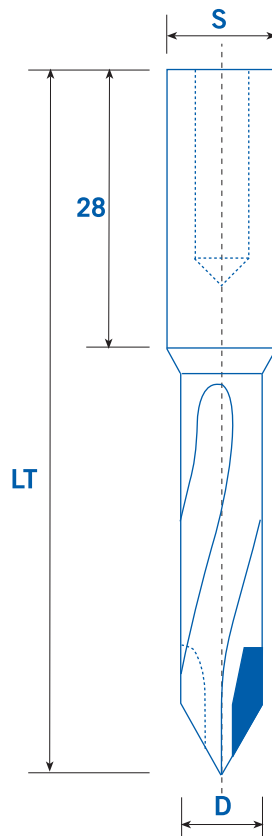

D	LT	S	Z	m/1'	n/max	Prezzo Price Preis Prix Precio	Affilatura Sharpening Erodieren Affûtage Afilado
6	70	10 x 28	2	1 / 5,5	3.000 / 9.000	€ 250,00	€ 130,00
8	70	10 x 28	2	1 / 5,5	3.000 / 9.000	€ 250,00	€ 130,00
10	70	10 x 28	2	1 / 5,5	3.000 / 9.000	€ 250,00	€ 130,00
12	70	10 x 28	2	1 / 5,5	3.000 / 9.000	€ 250,00	€ 130,00



## Punte per fori ciechi

Dowell drills

Dübellochbohrer

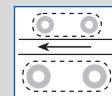

Mèches de perçage pour trous borgnes

Brocas para agujeros ciegos

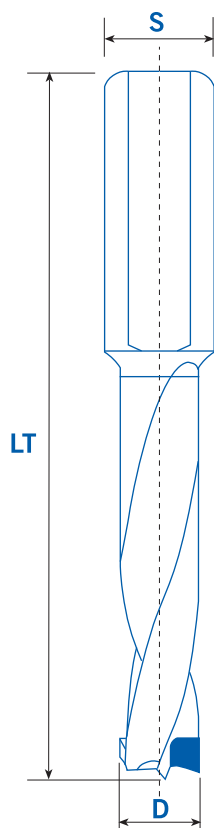

# PFC



D	LT	S	Z	 m/1'	 n/max	Prezzo Price Preis Prix Precio	Affilatura Sharpening Erodieren Affûtage Afilado
5	57,5	10 x 28	2	1 / 5,5	3.000 / 9.000	€ 200,00	€ 130,00
6	57,5	10 x 28	2	1 / 5,5	3.000 / 9.000	€ 200,00	€ 130,00
8	57,5	10 x 28	2	1 / 5,5	3.000 / 9.000	€ 200,00	€ 130,00
10	57,5	10 x 28	2	1 / 5,5	3.000 / 9.000	€ 230,00	€ 130,00
12	57,5	10 x 28	2	1 / 5,5	3.000 / 9.000	€ 230,00	€ 130,00
5	70	10 x 28	2	1 / 5,5	3.000 / 9.000	€ 200,00	€ 130,00
6	70	10 x 28	2	1 / 5,5	3.000 / 9.000	€ 200,00	€ 130,00
8	70	10 x 28	2	1 / 5,5	3.000 / 9.000	€ 200,00	€ 130,00
10	70	10 x 28	2	1 / 5,5	3.000 / 9.000	€ 230,00	€ 130,00
12	70	10 x 28	2	1 / 5,5	3.000 / 9.000	€ 230,00	€ 130,00



Svasatori

Countersinks



Aufstecksenker

Fraisoirs

Avellanadores

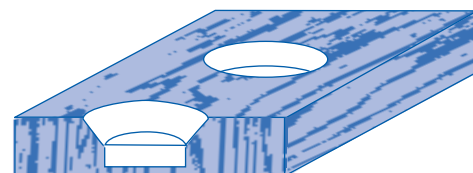
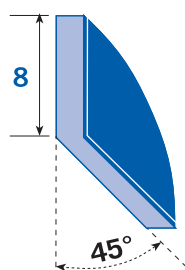
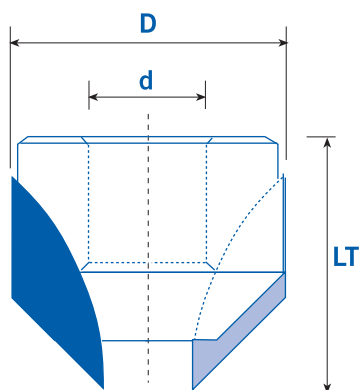
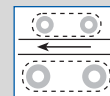
SVS



d	D	LT	Z			Prezzo Price Preis Prix Precio	Affilatura Sharpening Erodieren Affûtage Afilado
4	15,5	15	2	1 / 5,5	3.000 / 9.000	€ 240,00	€ 130,00
5	15,5	15	2	1 / 5,5	3.000 / 9.000	€ 240,00	€ 130,00
6	15,5	15	2	1 / 5,5	3.000 / 9.000	€ 240,00	€ 130,00
7	18	15	2	1 / 5,5	3.000 / 9.000	€ 240,00	€ 130,00
8	18	15	2	1 / 5,5	3.000 / 9.000	€ 240,00	€ 130,00
9	18	15	2	1 / 5,5	3.000 / 9.000	€ 240,00	€ 130,00
10	20	15	2	1 / 5,5	3.000 / 9.000	€ 240,00	€ 130,00
12	20	15	2	1 / 5,5	3.000 / 9.000	€ 240,00	€ 130,00



**Mozzo meccanico per truciolatore**

**Mechanical sleeve for hogging units**

**Zerspaner-Büchse**

**Manchon pour déchiqueteurs**

**Buje de sujeción por trituradores**

**BMT**

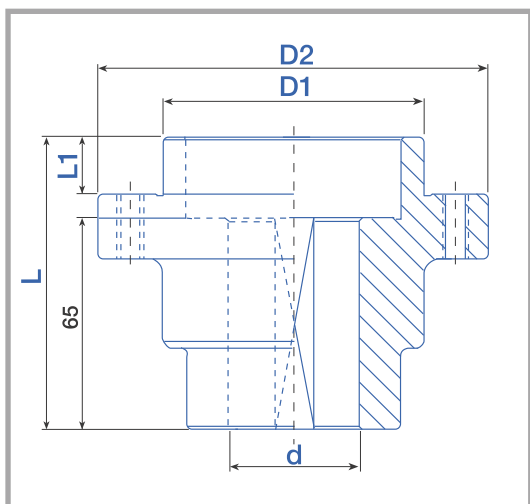

d (dkn)	D1	D2	L	L1	Prezzo Price Preis Prix Precio
35	80	120	95	17,5	€ 400,00
40	80	120	95	17,5	€ 400,00



**Mozzo meccanico incisori**

**Mechanical sleeve for scoring saws**

**Büchse für Ritzsägeblättern**

**Manchon pour inciseurs**

**Buje de sujeción por incisores**

**BMI**

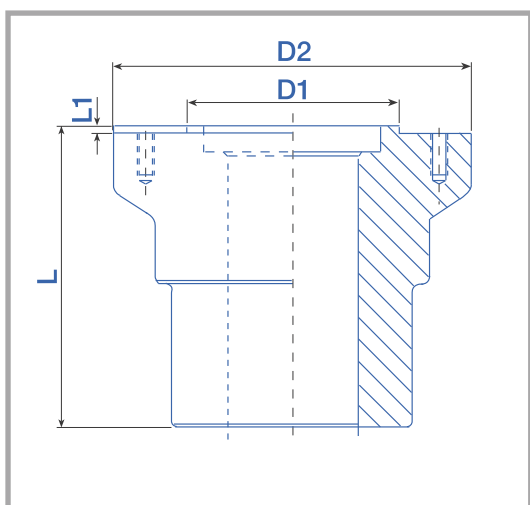

d (dkn)	D1	D2	L	L1	Prezzo Price Preis Prix Precio
25	65	100	76	2,2	€ 320,00
25	65	100	110	2,2	€ 320,00
30	65	100	76	2,2	€ 320,00
30	65	100	110	2,2	€ 320,00



## Mozzi Idro per macchine con chiavette

Hydro sleeves for machines with keys

Hydro-Büchse für Maschinen mit KN

Moyeux Hydro pour machines avec clavettes

Bujes Hydro por maquinaria con llaves

# BHT1

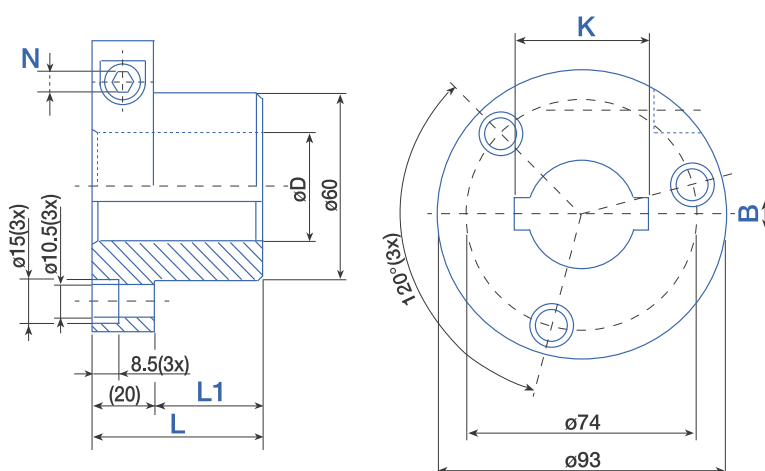

D	L	L1	B	K	N	Prezzo Price Preis Prix Precio
35	55	35	10	43	6	*
35	70	50	10	43	6	*
40	55	35	12	47	6	*

\* A richiesta.  
On request.  
Auf anfrage.  
Sur demande.  
A sollicitud.

Grado di equilibratura G6 a 9.000 giri/min.  
Balancing capacity G6 at 9,000 R.P.M.  
Auswuchtung-Kapazität G6 9.000 RPM  
Capacité d'équilibrage G6 à 9.000 RPM.  
Grado de equilibrado G6 a 9.000 RPM.



## Mozzi Idro per macchine con chiavette

Hydro sleeves for machines with keys

Hydro-Büchse für Maschinen mit KN

Moyeux Hydro pour machines avec clavettes

Bujes Hydro por maquinaria con llaves

# BHT2

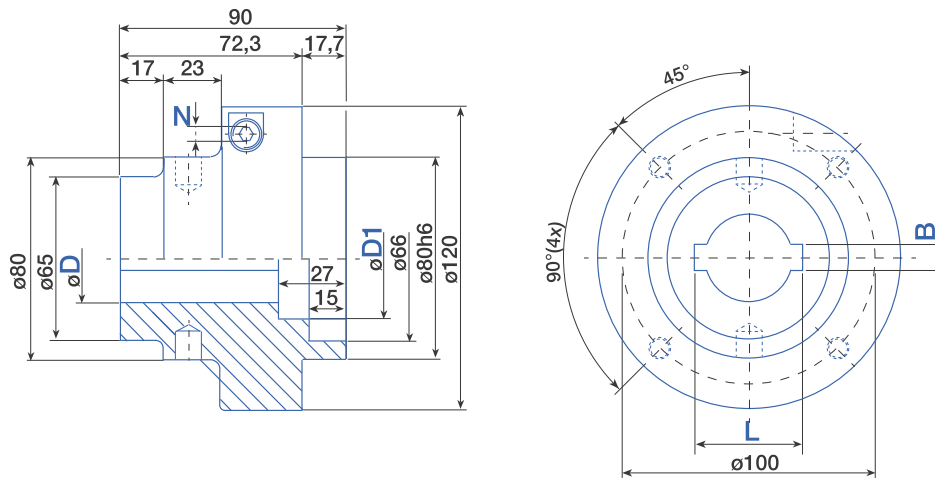

D	D1	B	L	N	Prezzo Price Preis Prix Precio
35	48	10	43	6	*
40	53	12	47	6	*

\* A richiesta.  
On request.  
Auf anfrage.  
Sur demande.  
A sollicitud.

Grado di equilibratura G6 a 9.000 giri/min.  
Balancing capacity G6 at 9,000 R.P.M.  
Auswuchtung-Kapazität G6 9.000 RPM  
Capacité d'équilibrage G6 à 9.000 RPM.  
Grado de equilibrado G6 a 9.000 RPM.



## Mozzi Idro con esagono per truciolatori

Hydro sleeves with hexagon clamping

Innensechs Hydro-Spannbüchsen für Zersparnern

Douilles Hydro à fixation hexagonale pour déchiqueteurs

Bujes Hydro con hexágono por trituradores

# BHT3

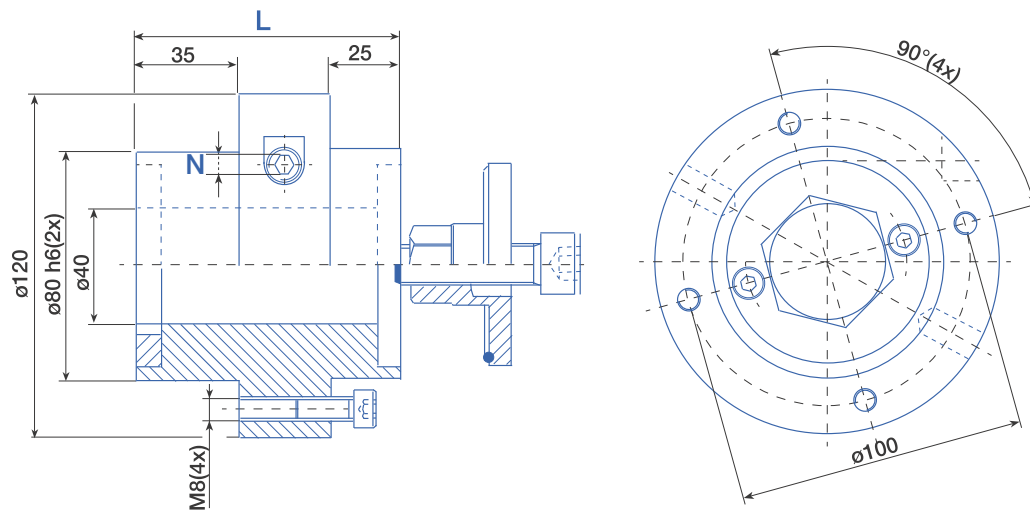

D	D2	L	Prezzo Price Preis Prix Precio
40	80	92	*

\* A richiesta.  
On request.  
Auf anfrage.  
Sur demande.  
A sollicitud.

Grado di equilibratura G6 a 9.000 giri/min.  
Balancing capacity G6 at 9,000 R.P.M.  
Auswuchtung-Kapazität G6 9.000 RPM  
Capacité d'équilibrage G6 à 9.000 RPM.  
Grado de equilibrado G6 a 9.000 RPM.



## Mozzi Idro con esagono per truciolatori

Hydro sleeve with hexagon clamping for hogging units

Innensechs Hydro-Spannbüchse für Zerspanern

Douille Hydro à fixation hexagonal pour déchiqueteurs

Buje Hydro con hexágono por trituradores

# BHT4

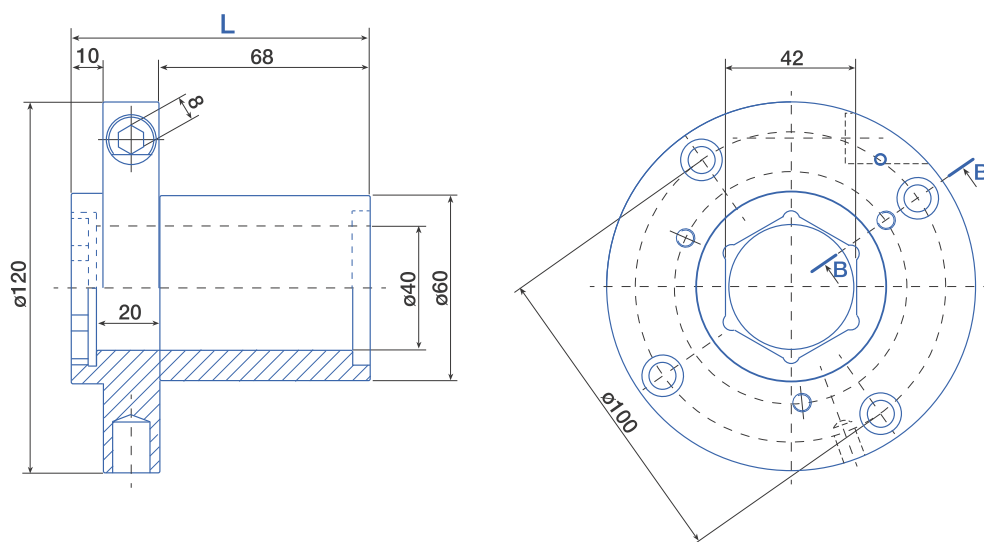

D	D2	L	Prezzo Price Preis Prix Precio
40	60	96	*

\* A richiesta.  
On request.  
Auf anfrage.  
Sur demande.  
A sollicitud.

Grado di equilibratura G6 a 9.000 giri/min.  
Balancing capacity G6 at 9,000 R.P.M.  
Auswuchtung-Kapazität G6 9.000 RPM  
Capacité d'équilibrage G6 à 9.000 RPM.  
Grado de equilibrado G6 a 9.000 RPM.





## Mozzi Idro con esagono per truciolatori

Hydro sleeve with hexagon clamping for hogging units

Innensechs Hydro-Spannbüchse für Zerspanern

Douille Hydro à fixation hexagonale pour déchiqueteurs

Buje Hydro con hexágono por trituradores

# BHT5

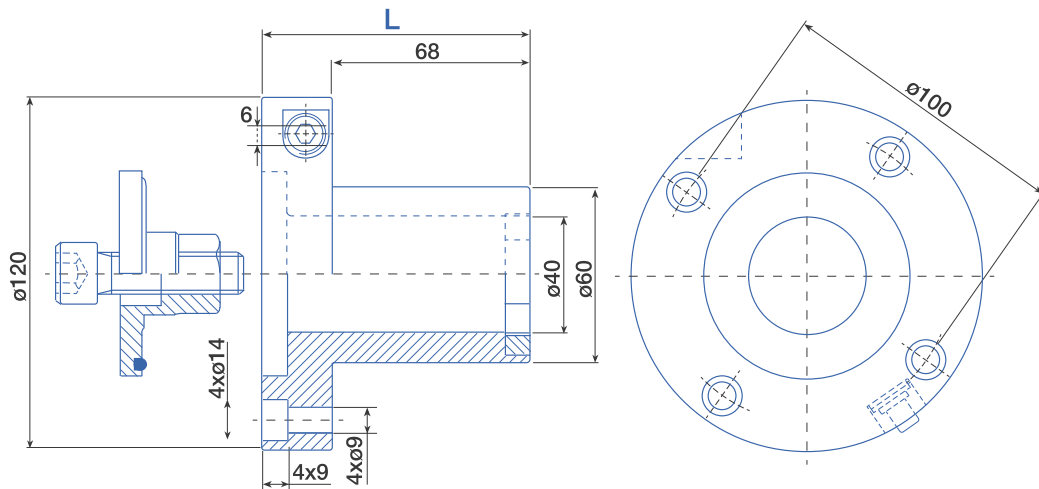

D	D2	L	Prezzo Price Preis Prix Precio
40	60	92	*

\* A richiesta.  
On request.  
Auf anfrage.  
Sur demande.  
A sollicitud.

Grado di equilibratura G6 a 9.000 giri/min.  
Balancing capacity G6 at 9,000 R.P.M.  
Auswuchtung-Kapazität G6 9.000 RPM  
Capacité d'équilibrage G6 à 9.000 RPM.  
Grado de equilibrado G6 a 9.000 RPM.



## Mozzi pneumatici

Pneumatic sleeves for hogging units

Büchse mit Schnellspannsystem für Zerspaner

Manchons à serrage rapide pour déchiqueteurs

Bujes fijación rápida por trituradores

# MPT

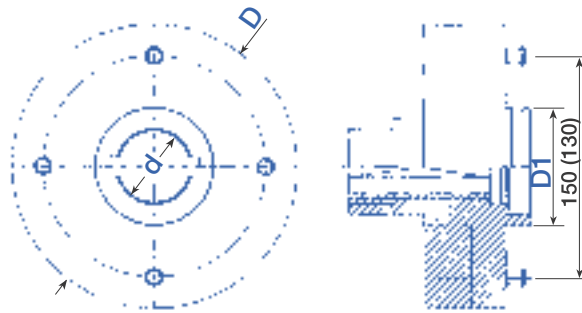

D1	D	d (dkn)	Prezzo Price Preis Prix Precio
80	192	35	*
80	192	40	*
60	160	35	*
60	160	40	*

\* A richiesta.  
On request.  
Auf anfrage.  
Sur demande.  
A sollicitud.

Grado di equilibratura G6 a 9.000 giri/min.  
Balancing capacity G6 at 9,000 R.P.M.  
Auswuchtung-Kapazität G6 9.000 RPM  
Capacité d'équilibrage G6 à 9.000 RPM.  
Grado de equilibrado G6 a 9.000 RPM.



Mandrino Idro

Hydro chuck

Hydro-Spannfutter

Mandrin Hydro

Mandril de expansión Hydro

BHY

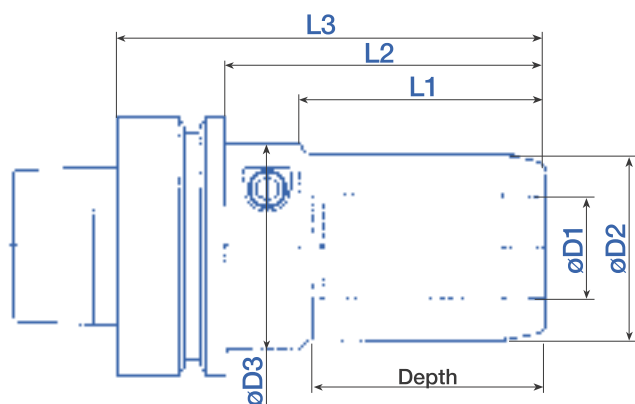

D1	D2	D3	L1	L2	L3	Depth	N	Max rpm	Prezzo Price Preis Prix Precio
12	32	40	43	61	87	40	5	24000	*
16	38	40	43	61	87	40	5	24000	*
20	40	50	55	73	99	52	5	24000	*
25	45	50	59	77	103	56	5	24000	*
1/2"	32	40	43	61	87	40	5	24000	*
5/8"	38	40	43	61	87	40	5	24000	*
3/4"	40	50	55	73	99	52	5	24000	*
1"	45	50	59	77	103	56	5	24000	*

\* A richiesta.  
On request.  
Auf anfrage.  
Sur demande.  
A sollicitud.

Grado di equilibratura G6,3 x 24.000 giri/min.  
Balancing capacity G6,3 x 24,000 R.P.M.  
Auswuchtung-Kapazität G6,3 x 24.000 RPM  
Capacité d'équilibrage G6,3 x 24.000 RPM.  
Grado de equilibrado G6,3 x 24.000 RPM.



## Mandrino Idro portafrese

Hydro cutter holder

Hydro-Fräsdornaufnahme

Mandrin Hydro porte-fraises

Portaherramientas Hydro

**MHF**

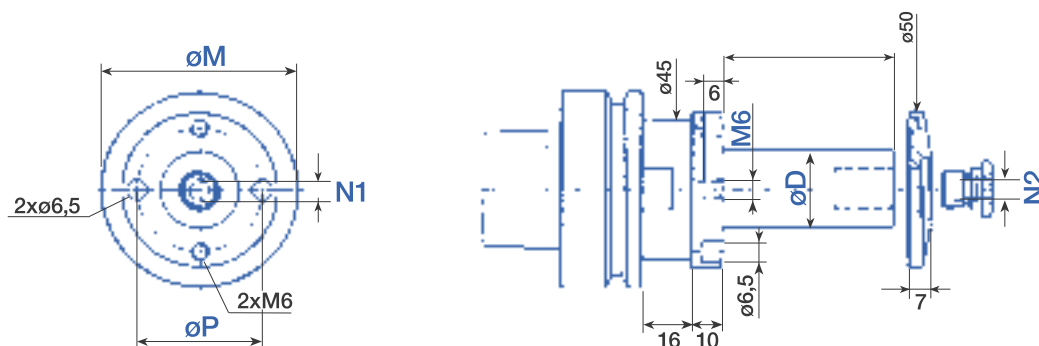

D	L	M	P	N1	N2	Prezzo Price Preis Prix Precio
20	40	45	32	6	8	*
20	55	45	32	6	8	*
25	40	50	40	6	8	*
25	55	50	40	6	8	*
30	40	58	48	6	8	*
30	55	58	48	6	8	*
30	80	58	48	6	8	*
30	100	58	48	6	8	*

D	L	M	P	N1	N2	Prezzo Price Preis Prix Precio
1"	40	50	40	6	8	*
1"	55	50	40	6	8	*
1"	80	50	40	6	8	*
1 1/4"	40	58	48	6	8	*
1 1/4"	55	58	48	6	8	*

\* A richiesta.  
On request.  
Auf anfrage.  
Sur demande.  
A sollicitud.

Grado di equilibratura G6,3 x 24.000 giri/min.  
Balancing capacity G6,3 x 24,000 R.P.M.  
Auswuchtung-Kapazität G6,3 x 24.000 RPM  
Capacité d'équilibrage G6,3 x 24.000 RPM.  
Grado de equilibrado G6,3 x 24.000 RPM.



# Mandrino a calettamento termico

Thermogrip tool holder

Dehnung-Schumpfutter

Mandrin de frettage

Portaherramientas a calentamento

# MCT

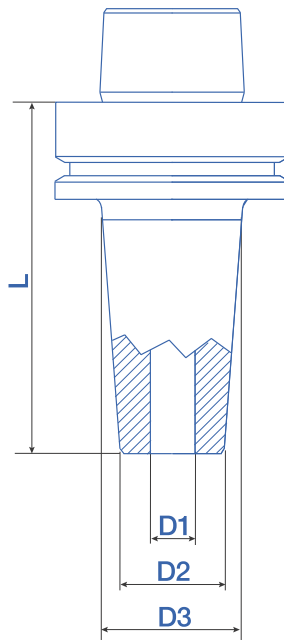

HSK F	A	D1	D2	D3	L1	L2	Prezzo Price Preis Prix Precio
63	75	12	27	34	47	38	*
	75	16	27	34	50	38	*
	75	20	33	42	50	38	*
	75	25	33	42	50	38	*

\* A richiesta.  
On request.  
Auf anfrage.  
Sur demande.  
A sollicitud.

Grado di equilibratura G6,3 x 40.000 giri/min.  
Balancing capacity G6,3 x 40,000 R.P.M.  
Auswuchtung-Kapazität G6,3 x 40.000 RPM  
Capacité d'équilibrage G6,3 x 40.000 RPM.  
Grado de equilibrado G6,3 x 40.000 RPM.



**MAP**

**Mandrino inox HSK63F a pinze**

**Stainless Steel HSK63F chuck**

**HSK63F Spannfutter rostfrei**

**Mandrin inox HSK63F à pinces**

**Portaherramientas con HSK63F inoxidable**

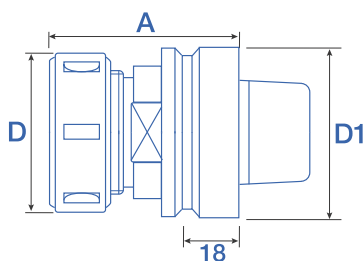

A	D	D1		Prezzo Price Preis Prix Precio
74	50	63	ER 32	€ 240,00
74	50	63	ER 32	€ 240,00
77	63	63	ER 40	€ 260,00
77	63	63	ER 40	€ 260,00
78	60	63	EOC 25	€ 270,00
78	60	63	EOC 25	€ 270,00

Grado di equilibratura G6,3 x 18.000 giri/min.

Balancing capacity G6,3 x 18.000 R.P.M.

Auswuchtung-Kapazität G6,3 x 18.000 RPM

Capacité d'équilibrage G6,3 x 18.000 RPM.

Grado de equilibrado G6,3 x 18.000 RPM.



## Mandrino HSK63F portafrese

HSK63F cutter holder

HSK63F Spannfutter

Mandrin porte fraises HSK63F

Portaherramientas HSK63F

# MPF63

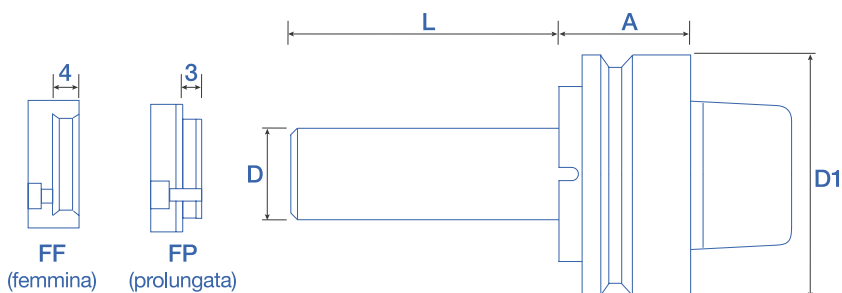

Cono	A	D	D1	L	Prezzo Price Preis Prix Precio
HSK 63 F	33	30	63	70 - 100	€ 215,00
HSK 63 F	33	30	63	105 - 130	€ 230,00
HSK 63 F	33	30	63	135 - 180	€ 245,00

Grado di equilibratura G6,3 x 24.000 giri/min.  
 Balancing capacity G6,3 x 24,000 R.P.M.  
 Auswuchtung-Kapazität G6,3 x 24.000 RPM  
 Capacité d'équilibrage G6,3 x 24.000 RPM.  
 Grado de equilibrado G6,3 x 24.000 RPM.



## Mandrino HSK85 portafrese

HSK85 cutter holder

HSK85 Spannfutter

Mandrin porte fraises HSK85

Portaherramientas HSK85

# MPF85

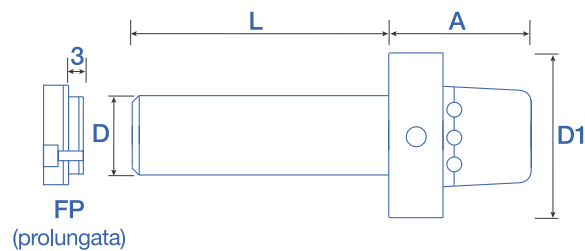

Cono	A	D	D1	L	Prezzo Price Preis Prix Precio
HSK 85	58	30 - 35 - 40	85	60 - 180	€ 480,00
HSK 85	58	30 - 35 - 40	85	185 - 240	€ 520,00

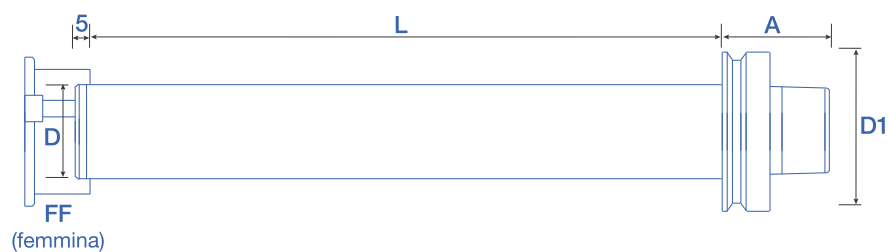

Cono	A	D	D1	L	Prezzo Price Preis Prix Precio
HSK 85S	58	50	85	320	€ 1.190,00

Grado di equilibratura G6,3 x 24.000 giri/min.  
 Balancing capacity G6,3 x 24,000 R.P.M.  
 Auswuchtung-Kapazität G6,3 x 24.000 RPM  
 Capacité d'équilibrage G6,3 x 24.000 RPM.  
 Grado de equilibrado G6,3 x 24.000 RPM.





Pinze

Collets

Spandorn

Pinces

Pinzas

**PNZ**

**ER32-DIN6499**

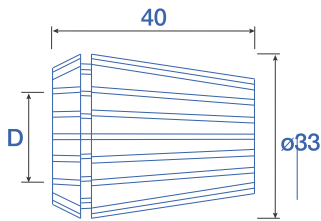

D	Prezzo Price Preis Prix Precio
1 - 20	€ 22,00

**ER40-DIN6499**

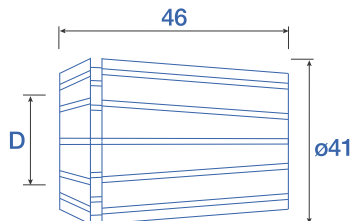

D	Prezzo Price Preis Prix Precio
2 - 30	€ 29,00

**EOC25-DIN6388 (462E)**

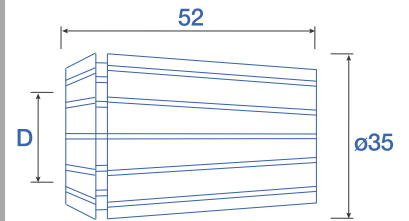

D	Prezzo Price Preis Prix Precio
1,5 - 25,4	€ 40,00

**ER32-DIN6499**  
(tenuta stagna)

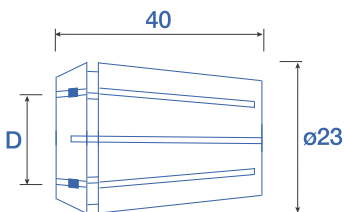

D	Prezzo Price Preis Prix Precio
1 - 20	€ 60,00

**ER40-DIN6499**  
(tenuta stagna)

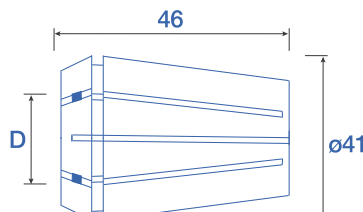

D	Prezzo Price Preis Prix Precio
2 - 25	€ 66,00

Grado di precisione >0,010  
 Level of accuracy >0,010  
 Genauigkeit >0,010  
 Degré de précision >0,010  
 Grado de precisión >0,010



Convogliatore trucioli per nesting

Chip conveyor for nesting

Spanleitglocke für Nesting-Bearbeitung

Convoyeur de copeaux pour nesting

Transportador de virutas para nesting

**GEP**

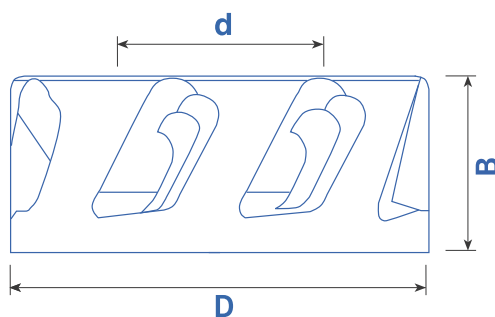

D	B	d	Rot.		Prezzo Price Preis Prix Precio
98	42	M 40 x 1,5	Dx / Rh	DIN6499 (ER32)	€ 980,00
98	42	M 50 x 1,5	Dx / Rh	DIN6499 (ER40)	€ 980,00
98	42	M 32 x 1,5	Dx / Rh	DIN6499 (ER25)	€ 980,00
98	42	M 48 x 2	Dx / Rh	DIN6499 (EOC25)	€ 980,00



# Chiavi dinamometriche per ghiera

Nut torque-wrenches

Drehmomentschlüssel für Nüsse

Clés dynamométriques pour écrous

Llaves de torque por tuercas

**CDG**

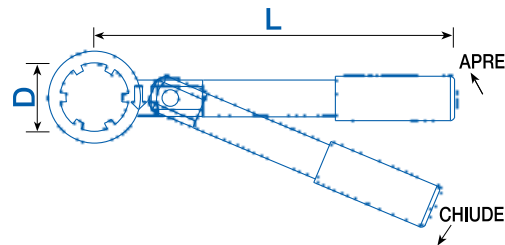

D	L	Nm		Prezzo Price Preis Prix Precio
35	185	40	ER 25	€ 140,00

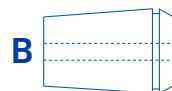
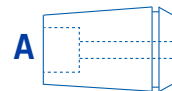
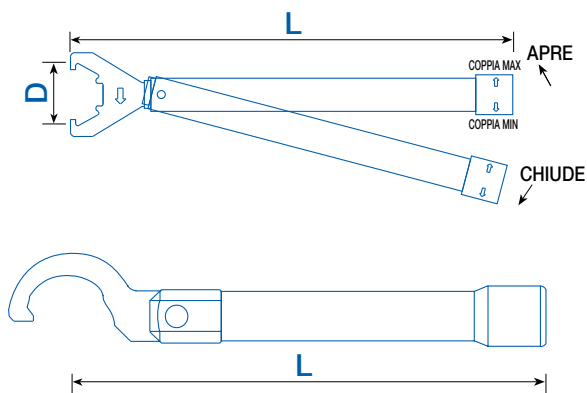

D	L	Nm A	Nm B		Prezzo Price Preis Prix Precio
40	400	40 - 55	45 - 55	ER 25	€ 205,00
50	400	66 - 70	60 - 70	ER 32	€ 205,00
63	450	110 - 120	80 - 90	ER 40	€ 245,00
58 - 62	380	110 - 120	190 - 200	DIN 6388	€ 300,00



**CST**

**Chiavi a settore**

**Wrenches**

**Schlüssel**

**Clés**

**Llaves**



**A**

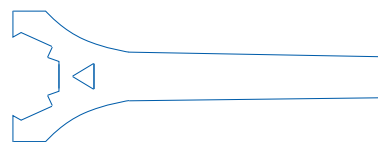

**B**

<b>A</b>		Prezzo Price Preis Prix Precio
34/38	DIN 6388 / EOC12	€ 38,00
40/42	DIN 6388 / EOC32	€ 35,00
58/62	DIN 6388 / EOC25	€ 56,00

<b>B</b>		Prezzo Price Preis Prix Precio
40	ER 32	€ 39,00
50	ER 40	€ 46,00
63	ER 25	€ 36,00



**SUR**

**Dispositivo di montaggio e smontaggio  
regolabile per mandrini standard**

**Adjustable mounting and demounting device  
for standard chucks**

**Gerät verstellbar für Montage und Demontage  
vom standard Spindel**

**Dispositif réglable pour montage et démontage  
mandrins standard**

**Dispositivo regulable para el montaje y desmontaje  
de los mandriles standard**

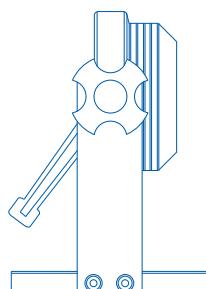

Mandrino - Cuck - Spannfutter Mandrin - Mandrile	Prezzo Price Preis Prix Precio
ISO30 con flangia Ø 50	€ 345,00
ISO30 con flangia Ø 58	€ 355,00
HSK63 con flangia Ø 63	€ 355,00
ISO40 con flangia Ø 63,5	€ 355,00



**Smontaconi  
per flangia Ø 80-85**

**Mounting and demounting device for chucks  
with Ø 80-85 flanges**

**Spannsystem  
für Flansch Ø 80-85**

**Dispositif de montage et démontage mandrins  
avec flange Ø 80-85**

**Dispositivo para el montaje y desmontaje de los mandriles  
por brida Ø 80-85**

**SUF**

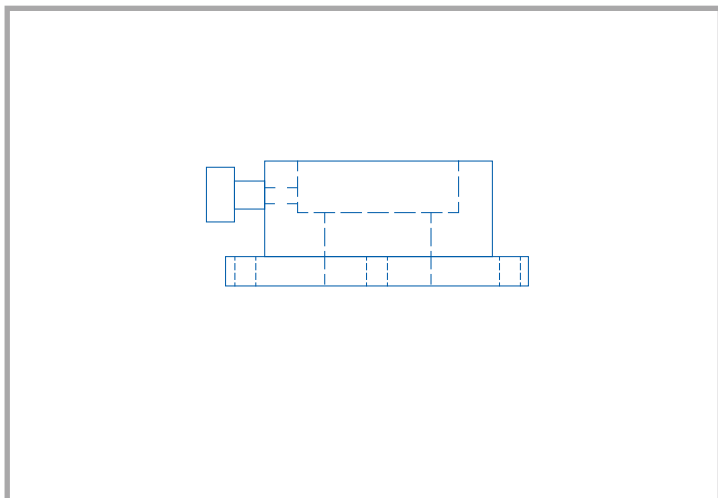

Mandrino - Cucks - Spannfutter Mandrin - Mandrile	Prezzo Price Preis Prix Precio
Ø 80	€ 410,00
Ø 85	€ 430,00



**Smontaconi  
chiave 41**

**Mounting and demounting device  
for 41 key chucks**

**Gerät verstellbar für Montage und Demontage  
vom Spindel mit Schlüssel 41**

**Dispositif de montage et démontage mandrins  
clé 41**

**Dispositivo para el montaje y desmontaje de los mandriles  
llaves 41**

**SUF2**

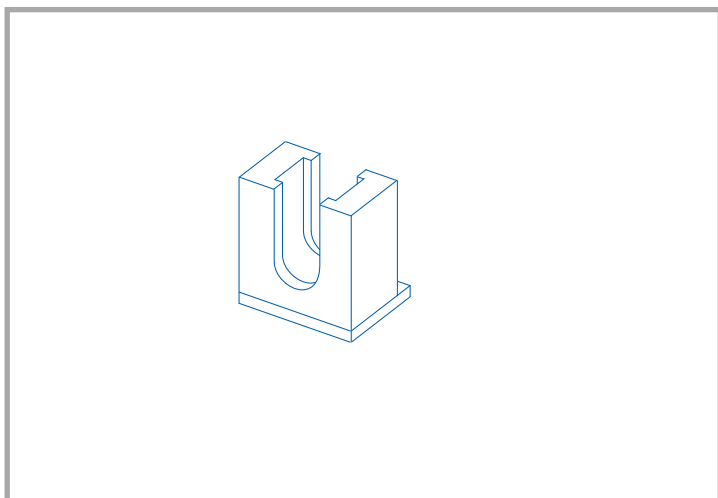

Mandrino - Cucks - Spannfutter Mandrin - Mandrile	Prezzo Price Preis Prix Precio
HSK63 con flangia Ø 63	€ 315,00
ISO40 con flangia Ø 63,5	€ 360,00



**Kit pulizia**

**Cleaning kit**

**Reinigungs-Kit**

**Kit de nettoyage**

**Kit de limpieza**

**KTP**

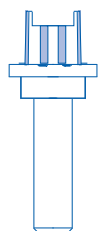

**1**



**2**



**3**

**1 + 2 + 3**

**Tampone pulitore sede coni - Tampone pulitore sede pinze - Spazzole per foro pinze**

**Buffer seat cleaner cones - Gripper seat pad cleaner - Brusches hole collets**

**Buffer sitzreiniger kegel - Gripper-sitzpolster-reiniger - Bursten lochzange**

**Nettoyeur de cônes - Pince de nettoyage de coussin de siège - Brosse de nettoyage de pince**

**Conos limpios asiento buffer - Gripper limpia la almohadilla del asiento - Escova de limpieza**

**Prezzo  
Price  
Preis  
Prix  
Precio**

**€ 195,00**



MANCINI UTENSILI

# Condizioni generali di vendita

## General sales conditions

## Verkaufsbedingungen

## Conditions générales de vente

## Condiciones generales de venta

**Ordini:** gli ordini dovranno essere trasmessi alla MANCINI UTENSILI S.n.c. preferibilmente per iscritto e, dove necessario, accompagnati da disegni accurati o da campioni dei profili da eseguire. Non sono accettati annullamenti trascorsi tre giorni dal ricevimento dell'ordine.

In caso d'annullamento dell'ordine, la MANCINI UTENSILI S.n.c. si riserva il diritto di richiedere il rimborso delle spese fino al momento sostenute per progettazione, acquisto materiali e lavorazioni eseguite. La MANCINI UTENSILI S.n.c. si riserva il diritto di modificare durante la lavorazione, le misure che, per motivi di sicurezza o di buon funzionamento dell'utensile, fossero inadeguate.

**Prezzi e condizioni di pagamento:** i prezzi si intendono sempre per merce resa F.co Fabbrica MANCINI UTENSILI S.n.c., in Pesaro e si riferiscono ad utensili che abbiano le caratteristiche conformi al catalogo. Per utensili con caratteristiche speciali preghiamo richiedere preventivo. Salvo accordi contrari, il pagamento s'intende per contanti a ricevimento fattura. Gli ordini per importi inferiori a € 200,00, dovranno essere sempre pagati in contanti o altrimenti spediti in contrassegno.

**Consegne** i termini di consegna si intendono valedoli solamente in condizioni normali di lavoro. Cause indipendenti dalla volontà della MANCINI UTENSILI S.n.c. (scioperi, interruzioni di trasporti, calamità naturali, ecc.), non possono costituire motivo di annullamento dell'ordine.

**Trasporto:** la merce viaggia sempre a rischio e pericolo del committente e, salvo disposizioni scritte contrarie, per la via ritenuta più vantaggiosa dalla MANCINI UTENSILI S.n.c. Il committente, in caso di danni e/o manomissioni durante il trasporto è tenuto a rivolgersi esclusivamente ai vettori che hanno provveduto allo stesso.

**Garanzia:** gli utensili prodotti dalla MANCINI UTENSILI S.n.c. sono sottoposti a controlli accurati e sono garantiti tecnicamente e qualitativamente. Non saranno presi in considerazione eventuali reclami trascorsi otto giorni dal ricevimento del materiale. Gli utensili sono accompagnati da un Certificato di Assicurazione che copre la MANCINI UTENSILI S.n.c. contro i danni che dovessero eventualmente arrecare a persone, cose o attrezzature. Nessuna garanzia verrà riconosciuta per difetti resi possibili da imperizia dell'operatore, da normale usura o manomissioni, da imperfetta affilatura o da condizioni di lavoro o da materiali non consentiti dalla natura stessa degli utensili.

**Controversie:** per ogni controversia il Foro competente è quello di Pesaro.

---

**Orders:** all orders will have to be passed on to MANCINI UTENSILI S.n.c. in written form and, when necessary, together with accurate drawings or samples of the profiles to be machined. Order's cancellations will not be accepted after 3 days from the order reception. In case of cancellation, MANCINI UTENSILI S.n.c. reserves the right to ask for reimbursement of the expenses sustained up to that particular status of preparation for project, material purchase and working carried out. MANCINI UTENSILI S.n.c. reserves the right to modify during the production phases, the dimensions which, for safety reasons or good functioning of the tool, might be considered necessary.

**Prices and payment conditions:** all prices are to be always intended for goods delivered on Ex Works MANCINI UTENSILI S.n.c. basis, in Pesaro - Italy - and they refer to tools whose characteristics are in conformity with its catalogue. Special tools are subject to separate quotations. The payment must be carried out within the agreed terms. Orders for tools whose value is lower than € 200,00, will have to be always paid cash or sent on C.O.D. basis.

**Delivery time:** the delivery terms are considered valid only in ordinary working conditions. Events or inconveniences not directly depending from MANCINI UTENSILI S.n.c. will (strikes, transports difficulties, natural calamities, wars, etc.), are not accepted as reasons for orders' cancellations.

**Transport:** the goods are supplied and travel always at buyer's risk and, with the exception of contrary written instructions, following the way considered the most advantageous by MANCINI UTENSILI S.n.c. The buyer, in case of damages and/or tampering during transportation, is bound to apply only to the carriers which provided for the service.

**Warranty:** all tools produced by MANCINI UTENSILI S.n.c. are subject to accurate controls and tests and are guaranteed both for their technical features and quality. Eventual complaints will not be considered and will be rejected if they reach MANCINI UTENSILI S.n.c. after eight days from the reception of the tools. All tools are supplied with an Insurance and Guarantee Certificate covering MANCINI UTENSILI S.n.c. against damages which may eventually be caused to persons, properties or equipments. No warranty will be recognised for defects made possible because of improper use by the operators, ordinary wear and tear, tampering, incorrect sharpening or because of working conditions or materials not permitted by the nature of the tool itself.

**Controversies:** for eventual controversy the competent Court of Justice is the one of Pesaro.

---

**Auftrag:** Die Aufträge müssen schriftlich an unsere Firma gesendet werden, und bei besonderer Anfrage, mit einem Muster oder mit einer technische Zeichnung des Profils für die Herstellung des Werkzeuges. Die Aufträge, nach drei Tagen des Auftragsdatum, können nicht mehr annulliert werden. Wenn ein Auftrag annulliert wird, hat die Firma MANCINI UTENSILI S.n.c. das Recht die Rückzahlung der Produktionskosten zu verlangen. Die Firma MANCINI UTENSILI S.n.c. hat das Recht während der Herstellung, die Masse der Werkzeuge zu verändern, auf Grund einer besseren Qualität und Sicherheit.

**Preise und Zahlungsbedingungen:** Die Preise sind frei Haus ausgerechnet und gehören zu unseren Standard Werkzeugen die im Katalog abgebildet sind. Für Werkzeuge mit besonderen technische Daten, bitten wir um einer Preisanfrage. Wenn nichts anderes vereinbart, sind die Rechnungen sofort zahlbar. Die Aufträge mit einem Betrag unten € 200,00 müssen bar bezahlt werden oder werden mit einer Vorzahlung geliefert.

**Lieferung:** Die Zeitlieferung wird durch normale Arbeitstage ausgerechnet. Transport Verspätungen, Streick, oder Natur Katastrophen, usw die nicht von MANCINI UTENSILI S.n.c.abhängig sind, sind kein Grund der Annullierung des Auftrags. Alle Lieferungen der Ware versenden wir auf Rechnung und Gefahr des Bestellers. Für Schaden oder Verspätung der Ware während der Lieferung, kann der Besteller sich nur an den Transporteur wenden.

**Garantie:** Die Werkzeuge von der MANCINI UTENSILI S.n.c. Herstellung werden durch technische Kontrolle nach geprüft und werden qualitativ garantiert. Reklamationen nach 8 Tagen der Güterempfangung werden nicht acceptiert. Alle Werkzeuge haben einen Garantie-Zertifikat um sich von eventuelle Schaden zu beschützen. Die Garantie ist in folgenden Fällen nicht gültig: - ein falscher Gebrauch der Werkzeuge; - ein Bedienungsfehler des Operateurs; - eine unperfekte Nachschleifung der Werkzeugen; - eine normale Werkzeug-Abnutzung; - Arbeit oder Material Standes die nicht erlaubt sind. Alle Fehler die nicht von der Firma Mancini abhängig sind, werden nicht garantiert.

**Streitigkeiten:** Gerichtsstand bei Streitigkeiten ist das für unseren Firmensitz zuständige Gericht in Pesaro - Italien.





MANCINI UTENSILI

# Condizioni generali di vendita

## General sales conditions

## Verkaufsbedingungen

## Conditions générales de vente

## Condiciones generales de venta

**Commandes:** les commandes doivent être transmises à la MANCINI UTENSILI S.n.c. de préférence par écrit et si nécessaire, accompagnées d'un plan ou d'un échantillon pour exécuter le profil. Les commandes, après trois jours de la date de réception de la commande, ne peuvent plus être annulées. Dans le cas des commandes annulées, la MANCINI UTENSILI S.n.c. se réserve le droit d'exiger le remboursement des frais de projet, de l'achat du matériel, et de l'usinage exécuté jusqu'à ce moment. La MANCINI UTENSILI S.n.c. se réserve le droit de modifier, pendant la fabrication, les mesures qui pourraient être inappropriées, pour raison de sécurité et pour un bon fonctionnement de l'outil.

**Prix et conditions de payment:** les prix sont considérés franco de l'Établissement MANCINI UTENSILI S.n.c. en Pesaro - Italie. Les prix concernent les outils qui ont les caractéristiques conformes au catalogue. Concernant tous les autres outils non inclus dans le catalogue avec des caractéristiques spéciales, nous demandons de la part du client une demande de prix. Le payment est immédiat sous présentation de la facture, sauf accords différents. Les commandes avec un montant inférieur à € 200,00 doivent être payées comptant ou livrées avec payment reçu.

**Livraison:** les termes de livraison ne sont valables que sous les conditions de travail normales. Les causes indépendantes à notre volonté (grève, interruption des transports, dégâts naturels, ou autre), ne peuvent être motif d'annulation de la commande.

**Transport:** la marchandise voyage sous risques et périls de l'acheteur et, sauf dispositions différentes, la MANCINI UTENSILI S.n.c. s'engage à organiser le transport qui est considéré le plus avantageux. Toute éventuelle réclamation ou endommagement de la marchandise pendant le transport doit être adressée directement au transporteur au moment de la réception de la marchandise.

**Garantie:** les outils fabriqués par la MANCINI UTENSILI S.n.c. sont soumis à de précis contrôles et sont sous garantie aussi bien techniquement qu'au point de vue de la qualité. Les éventuelles réclamations après 8 jours de la date de la réception de la marchandise ne seront pas prises en considération. Les outils sont accompagnés par un certificat d'assurance qui couvre la MANCINI UTENSILI S.n.c. des endommagements qui pourraient éventuellement être causés à des personnes, choses ou équipements. Aucune garantie sera reconnue dans les cas suivants: normale usure de l'outil, mauvaise utilisation de l'outil, fausse manoeuvre de l'opérateur, mauvais affûtage, conditions de travail ou matériaux non consentis pour l'utilisation de l'outil même.

**Incompréhensions:** pour toutes incompréhensions, le tribunal auquel s'adresser est situé à Pesaro.

**Pedidos:** los pedidos tendrán que ser transmitidos a la MANCINI UTENSILI S.n.c. por escrito y, cuando necesario, acompañados con dibujos esmerados o muestras de perfiles y material a trabajar. No serán aceptadas anulaciones transcurridos tres días de la recepción del pedido. En caso de anulación del pedido, la MANCINI UTENSILI S.n.c. se reserva el derecho de requerir el reembolso de los gastos hasta el momento soportados, por planteamiento, adquisición materiales y trabajos ejecutados. La MANCINI UTENSILI S.n.c. se reserva el derecho de modificar, durante la construcción, las medidas que, por motivos de seguridad o buen funcionamiento de la herramienta, fuesen inadecuadas.

**Precios y condiciones de pago:** los precios se entienden siempre con entrega de la mercancía F.co Fabrica MANCINI UTENSILI S.n.c., en Pesaro - Italia - y se refieren a herramientas que hayan características conformes a su catalogo. Por herramientas con características especiales se ruega pedir presupuesto. Con la excepción de acuerdos en contra, el pago se entiende al contado a la recepción de la factura. Los pedidos por importes inferiores a € 200,00, deberán ser siempre pagados al contado o, de otra forma, la mercancía será despachada con pago contra reembolso.

**Entregas:** las fechas de entrega se entienden valederas solamente en condiciones normales de trabajo. Causas independientes de la voluntad de la MANCINI UTENSILI S.n.c. (huelgas, paros de los transportes, calamidades naturales, guerras, etc.), no pueden constituir razón de anulación del pedido.

**Transporte:** la mercadería viaja siempre de cuenta y riesgo del comprador y, salvo disposiciones escritas en contra, por la vía retenida la más ventajosa por la MANCINI UTENSILI S.n.c. El comprador, en caso de daños y/o manumisiones durante el transporte, es obligado a dirigirse exclusivamente a las compañías de transporte que han proveído al mismo.

**Garantía:** las herramientas producidas por la MANCINI UTENSILI S.n.c. son sometidas a controles esmerados y son garantizadas sea por sus características técnicas que por su elevada calidad. No se tomarán en consideración eventuales reclamaciones transcurridos ocho días de la recepción del material. Las herramientas son acompañadas con un Certificado de Seguro que protege la MANCINI UTENSILI S.n.c. contra daños que debiesen ocasionar, eventualmente, a personas, cosas o equipos. Ninguna garantía será reconocidas por defectos hechos posibles por impericia del operador, por normal desgaste o manumisiones, por imperfecta afiladura o por condiciones de trabajo o materiales no consentidos de la natura misma de las herramientas.

**Controversias:** por todas controversias el Foro competente es el Foro de Pesaro.